

**EDWARD F. POOLOS**  
DIRECTOR

**JEFFERY W. KITCHENS**  
DEPUTY DIRECTOR



**KAY IVEY**  
GOVERNOR

Alabama Department of Environmental Management  
[adem.alabama.gov](http://adem.alabama.gov)

1400 Coliseum Blvd. 36110-2400 ■ Post Office Box 301463  
Montgomery, Alabama 36130-1463  
(334) 271-7700 ■ FAX (334) 271-7950

March 17, 2026

Mr. Eduardo Mejia  
Owner/Manager  
Tremendous Stone, LLC  
PO Box 1786  
Oneonta, AL 35121

RE: Draft Permit  
Rocky Mountain Quarry  
NPDES Permit Number AL0083950  
Blount County (009)

Dear Mr. Mejia:

Transmitted herein is a draft of the above referenced permit. Please review the enclosed draft permit carefully. If previously permitted, the draft may contain additions/revisions to the language in your current permit. Please submit any comments on the draft permit to the Department within 30 days from the date of receipt of this letter.

Since the Department has made a tentative decision to reissue the above referenced permit, ADEM Admin. Code r. 335-6-6-.21 requires a public notice of the draft permit followed by a period of at least 30 days for public comment before the permit can be issued. The United States Environmental Protection Agency will also receive the draft permit for review during the 30-day public comment period.

Any mining, processing, construction, land disturbance, or other regulated activity proposed to be authorized by this draft permit is prohibited prior to the effective date of the formal permit. Any mining or processing activity within the drainage basin associated with each permitted outfall which is conducted prior to Departmental receipt of certification from a professional engineer licensed to practice in the State of Alabama, that the Pollution Abatement/Prevention Plan was implemented according to the design plan, or notification from the Alabama Surface Mining Commission that the sediment control structures have been certified, is prohibited.

This permit requires Discharge Monitoring Reports (DMR) to be submitted utilizing the Department's web-based electronic reporting system. Please read Part I.D of the permit carefully and visit <https://aepacs.adem.alabama.gov/nviro/ncore/external/home>.

Should you have any questions concerning this matter, please contact Skylar Wilson at (334) 274-4231 or [eva.wilson@adem.alabama.gov](mailto:eva.wilson@adem.alabama.gov).

Sincerely,

A handwritten signature in blue ink that reads "William D. McClimans".

William D. McClimans, Chief  
Mining and Natural Resource Section  
Stormwater Management Branch  
Water Division

WDM/esw

File: DPER/52807

cc: Skylar Wilson, ADEM  
Environmental Protection Agency Region IV  
Alabama Department of Conservation and Natural Resources  
U.S. Fish and Wildlife Service  
Alabama Historical Commission  
Advisory Council on Historic Preservation  
U.S. Army Corps of Engineers Mobile District  
Alabama Department of Labor



**Birmingham Office**  
110 Vulcan Road  
Birmingham, AL 35209-4702  
(205) 942-6168  
(205) 941-1603 (FAX)

**Decatur Office**  
2715 Sandlin Road, S.W.  
Decatur, AL 35603-1333  
(256) 353-1713  
(256) 340-9359 (FAX)

**Coastal Office**  
1615 South Broad Street  
Mobile, AL 36605  
(251) 450-3400  
(251) 479-2593 (FAX)



# NATIONAL POLLUTANT DISCHARGE ELIMINATION SYSTEM PERMIT

PERMITTEE: Tremedous Stone, LLC  
P.O. Box 1786  
Oneonta, AL 35121

FACILITY LOCATION: Rocky Mountain Quarry  
76 Rocky Mountain Road  
Oneonta, AL 35121  
Blount County  
T12S, R2E, S8  
T12S, R2E, S9

PERMIT NUMBER: AL0083950

DSN & RECEIVING STREAM: 001 - 1 Unnamed Tributary to Calvert Prong/Groundwater

*In accordance with and subject to the provisions of the Federal Water Pollution Control Act, as amended, 33 U.S.C. §§1251-1388 (the "FWPCA"), the Alabama Water Pollution Control Act, as amended, Code of Alabama 1975, §§ 22-22-1 to 22-22-14 (the "AWPCA"), the Alabama Environmental Management Act, as amended, Code of Alabama 1975, §§22-22A-1 to 22-22A-17, and rules and regulations adopted thereunder, and subject further to the terms and conditions set forth in this permit, the Permittee is hereby authorized to discharge into the above-named receiving waters.*

ISSUANCE DATE:

EFFECTIVE DATE:

EXPIRATION DATE:

## Draft

Alabama Department of Environmental Management  
Water Division Chief

**NATIONAL POLLUTANT DISCHARGE ELIMINATION SYSTEM (NPDES) PERMIT**  
**Sandstone Quarry, Mineral Loading, Mineral Storage, Mineral Transportation, and**  
**Associated Areas**

**TABLE OF CONTENTS**

<b>PART I</b>	<b>DISCHARGE LIMITATIONS, CONDITIONS, AND REQUIREMENTS</b>	
	A. DISCHARGE LIMITATIONS AND MONITORING REQUIREMENTS.....	4
	B. REQUIREMENTS TO ACTIVATE A PROPOSED MINING OUTFALL.....	4
	C. DISCHARGE MONITORING AND RECORD KEEPING REQUIREMENTS .....	4
	1. Sampling Schedule and Frequency.....	4
	2. Measurement Frequency .....	5
	3. Monitoring Schedule.....	5
	4. Sampling Location.....	6
	5. Representative Sampling .....	6
	6. Test Procedures .....	6
	7. Recording of Results .....	7
	8. Routine Inspection by Permittee.....	7
	9. Records Retention and Production.....	8
	10. Monitoring Equipment and Instrumentation .....	8
	D. DISCHARGE REPORTING REQUIREMENTS .....	8
	1. Requirements for Reporting of Monitoring.....	8
	2. Noncompliance Notification .....	10
	3. Reduction, Suspension, or Termination of Monitoring and/or Reporting.....	11
	E. OTHER REPORTING AND NOTIFICATION REQUIREMENTS.....	12
	1. Anticipated Noncompliance.....	12
	2. Termination of Discharge.....	12
	3. Updating Information .....	12
	4. Duty to Provide Information.....	13
	F. SCHEDULE OF COMPLIANCE.....	13
<b>PART II</b>	<b>OTHER REQUIREMENTS, RESPONSIBILITIES, AND DUTIES</b>	
	A. OPERATIONAL AND MANAGEMENT REQUIREMENTS.....	14
	1. Facilities Operation and Management .....	14
	2. Pollution Abatement and/or Prevention Plan .....	14
	3. Best Management Practices (BMPs).....	14
	4. Biocide Additives.....	16
	5. Facility Identification.....	16
	6. Removed Substances .....	16
	7. Loss or Failure of Treatment Facilities .....	16
	8. Duty to Mitigate.....	17
	B. BYPASS AND UPSET .....	17
	1. Bypass.....	17
	2. Upset.....	18
	C. PERMIT CONDITIONS AND RESTRICTIONS.....	19
	1. Prohibition against Discharge from Facilities Not Certified .....	19
	2. Permit Modification, Suspension, Termination, and Revocation .....	19
	3. Automatic Expiration of Permits for New or Increased Discharges.....	20
	4. Transfer of Permit.....	21
	5. Groundwater .....	21
	6. Property and Other Rights.....	21

D.	RESPONSIBILITIES .....	21
1.	Duty to Comply .....	21
2.	Change in Discharge .....	22
3.	Compliance with Toxic or Other Pollutant Effluent Standard or Prohibition .....	22
4.	Compliance with Water Quality Standards and Other Provisions.....	22
5.	Compliance with Statutes and Rules .....	23
6.	Right of Entry and Inspection.....	23
7.	Duty to Reapply or Notify of Intent to Cease Discharge.....	23
<b>PART III</b>	<b>ADDITIONAL REQUIREMENTS, CONDITIONS, AND LIMITATIONS</b>	
A.	CIVIL AND CRIMINAL LIABILITY.....	25
1.	Tampering.....	25
2.	False Statements .....	25
3.	Permit Enforcement.....	25
4.	Relief From Liability.....	25
B.	OIL AND HAZARDOUS SUBSTANCE LIABILITY.....	25
C.	AVAILABILITY OF REPORTS.....	25
D.	DEFINITIONS .....	25
E.	SEVERABILITY.....	30
F.	PROHIBITIONS AND ACTIVIES NOT AUTHORIZED.....	30
G.	DISCHARGES TO IMPAIRED WATERS.....	30

## PART I DISCHARGE LIMITATIONS, CONDITIONS, AND REQUIREMENTS

### A. DISCHARGE LIMITATIONS AND MONITORING REQUIREMENTS

During the period beginning on the effective date of this Permit and lasting through the expiration date of this Permit, the Permittee is authorized to discharge from each point source identified on Page 1 of this Permit and described more fully in the Permittee's application, if the outfalls have been constructed and certified. Discharges shall be limited and monitored by the Permittee as specified below:

Parameter	Discharge Limitations			Monitoring Requirements	
	Daily Minimum	Monthly Average	Daily Maximum	Sample Type	Measurement Frequency <sup>1</sup>
pH 00400	6.0 s.u.	-----	8.5 s.u.	Grab	2/Month
Solids, Total Suspended 00530	-----	25.0 mg/L	45.0 mg/L	Grab	2/Month
Flow, In Conduit or Thru Treatment Plant <sup>2</sup> 50050	-----	Report MGD	Report MGD	Instantaneous	2/Month

### B. REQUIREMENTS TO ACTIVATE A PROPOSED MINING OUTFALL

1. Discharge from any point source identified on Page 1 of this Permit which is a proposed outfall is not authorized by this Permit until the outfall has been constructed and certification received by the Department from a professional engineer, registered in the State of Alabama, certifying that such facility has been constructed according to good engineering practices and in accordance with the Pollution Abatement and/or Prevention (PAP) Plan.
2. Certification required by Part I.B.1. shall be submitted on a completed ADEM Form 432. The certification shall include the latitude and longitude of the constructed and certified outfall.
3. Discharge monitoring and Discharge Monitoring Report (DMR) reporting requirements described in Part I.C. of this Permit do not apply to point sources that have not been constructed and certified.
4. Upon submittal of the certification required by Part I.B.1. to the Department, all monitoring and DMR submittal requirements shall apply to the constructed and certified outfall.

### C. DISCHARGE MONITORING AND RECORD KEEPING REQUIREMENTS

1. **Sampling Schedule and Frequency**
  - a. The Permittee shall collect at least one grab sample of the discharge to surface waters from each constructed and certified point source identified on Page 1 of this Permit and described more fully in the Permittee's application twice per month at a rate of at least every other week if a discharge occurs at any time during the two week period, but need not collect more than two samples per calendar month. Each sample collected shall be analyzed for each parameter specified in Part I.A. of this Permit.

<sup>1</sup> See Part I.C.2. for further measurement frequency requirements.

<sup>2</sup> Flow must be determined at the time of sample collection by direct measurement, calculation, or other method acceptable to the Department.

- b. If the final effluent is pumped in order to discharge (e.g. from incised ponds, old highwall cuts, old pit areas or depressions, etc.), the Permittee shall collect at least one grab sample of the discharge from each point source identified on Page 1 of this Permit and described more fully in the Permittee's application each quarterly (three month) monitoring period if a discharge occurs at any time during the quarterly monitoring period which results from direct pumped drainage. Each sample collected shall be analyzed for each parameter specified in Part I.A. of this Permit.
- c. The Permittee may increase the frequency of sampling listed in Parts I.C.1.a and I.C.1.b; however, all sampling results must be reported to the Department and included in any calculated results submitted to the Department in accordance with this Permit.

## 2. Measurement Frequency

Measurement frequency requirements found in Part I.A. shall mean:

- a. A measurement frequency of one day per week shall mean sample collection on any day of discharge which occurs every calendar week.
- b. A measurement frequency of two days per month shall mean sample collection on any day of discharge which occurs every other week, but need not exceed two sample days per month.
- c. A measurement frequency of one day per month shall mean sample collection on any day of discharge which occurs during each calendar month.
- d. A measurement frequency of one day per quarter shall mean sample collection on any day of discharge which occurs during each calendar quarter.
- e. A measurement frequency of one day per six months shall mean sample collection on any day of discharge which occurs during the period of January through June and during the period of July through December.
- f. A measurement frequency of one day per year shall mean sample collection on any day of discharge which occurs during each calendar year.

## 3. Monitoring Schedule

The Permittee shall conduct the monitoring required by Part I.A. in accordance with the following schedule:

- a. MONITORING REQUIRED MORE FREQUENTLY THAN MONTHLY AND MONTHLY shall be conducted during the first full month following the effective date of coverage under this Permit and every month thereafter. More frequently than monthly and monthly monitoring may be done anytime during the month, unless restricted elsewhere in this Permit, but the results should be reported on the last Discharge Monitoring Report (DMR) due for the quarter (i.e., with the March, June, September, and December DMRs).
- b. QUARTERLY MONITORING shall be conducted at least once during each calendar quarter. Calendar quarters are the periods of January through March, April through June, July through September, and October through December. The Permittee shall conduct the quarterly monitoring during the first complete calendar quarter following the effective date of this Permit and is then required to monitor once during each quarter thereafter. Quarterly monitoring may be done anytime during the quarter, unless restricted elsewhere in this

Permit, but the results should be reported on the last DMR due for the quarter (i.e., with the March, June, September, and December DMRs).

- c. SEMIANNUAL MONITORING shall be conducted at least once during the period of January through June and at least once during the period of July through December. The Permittee shall conduct the semiannual monitoring during the first complete semiannual calendar period following the effective date of this Permit and is then required to monitor once during each semiannual period thereafter. Semiannual monitoring may be done anytime during the semiannual period, unless restricted elsewhere in this Permit, but it should be reported on the last DMR due for the month of the semiannual period (i.e., with the June and December DMRs).
- d. ANNUAL MONITORING shall be conducted at least once during the period of January through December. The Permittee shall conduct the annual monitoring during the first complete calendar annual period following the effective date of this Permit and is then required to monitor once during each annual period thereafter. Annual monitoring may be done anytime during the year, unless restricted elsewhere in this Permit, but it should be reported on the December DMR.

**4. Sampling Location**

Unless restricted elsewhere in this Permit, samples collected to comply with the monitoring requirements specified in Part I.A. shall be collected at the nearest accessible location just prior to discharge and after final treatment, or at an alternate location approved in writing by the Department.

**5. Representative Sampling**

Sample collection and measurement actions taken as required herein shall be representative of the volume and nature of the monitored discharge and shall be in accordance with the provisions of this Permit.

**6. Test Procedures**

For the purpose of reporting and compliance, Permittees shall use one of the following procedures:

- a. For parameters with an EPA established Minimum Level (ML), report the measured value if the analytical result is at or above the ML and report "0" for values below the ML. Test procedures for the analysis of pollutants shall conform to 40 CFR Part 136, guidelines published pursuant to Section 304(h) of the FWPCA, 33 U.S.C. Section 1314(h), and ADEM Standard Operating Procedures. If more than one method for analysis of a substance is approved for use, a method having a minimum level lower than the permit limit shall be used. If the minimum level of all methods is higher than the permit limit, the method having the lowest minimum level shall be used and a report of less than the minimum level shall be reported as zero and will constitute compliance, however should EPA approve a method with a lower minimum level during the term of this Permit the Permittee shall use the newly approved method.
- b. For pollutant parameters without an established ML, an interim ML may be utilized. The interim ML shall be calculated as 3.18 times the Method Detection Level (MDL) calculated pursuant to 40 CFR Part 136, Appendix B.

Permittees may develop an effluent matrix-specific ML, where an effluent matrix prevents attainment of the established ML. However, a matrix specific ML shall be based upon proper laboratory method and technique. Matrix-specific MLs must be approved by the

Department, and may be developed by the Permittee during permit issuance, reissuance, modification, or during compliance schedule.

In either case the measured value should be reported if the analytical result is at or above the ML and "0" reported for values below the ML.

- c. For parameters without an EPA established ML, interim ML, or matrix-specific ML, a report of less than the detection limit shall constitute compliance if the detection limit of all analytical methods is higher than the permit limit using the most sensitive EPA approved method. For the purpose of calculating a monthly average, "0" shall be used for values reported less than the detection limit.

The Minimum Level utilized for procedures identified in Parts I.C.6.a. and b. shall be reported on the Permittee's DMR. When an EPA approved test procedure for analysis of a pollutant does not exist, the Director shall approve the procedure to be used.

## **7. Recording of Results**

For each measurement or sample taken pursuant to the requirements of this Permit, the Permittee shall record the following information:

- a. The facility name and location, point source number, date, time, and exact place of sampling or measurements;
- b. The name(s) of person(s) who obtained the samples or measurements;
- c. The dates and times the analyses were performed;
- d. The name(s) of the person(s) who performed the analyses;
- e. The analytical techniques or methods used including source of method and method number; and
- f. The results of all required analyses.

## **8. Routine Inspection by Permittee**

- a. The Permittee shall inspect all point sources identified on Page 1 of this Permit and described more fully in the Permittee's application and all treatment or control facilities or systems used by the Permittee to achieve compliance with the terms and conditions of this Permit at least as often as the applicable sampling frequency specified in Part I.C.1 of this Permit.
- b. The Permittee shall maintain a written log for each point source identified on Page 1 of this Permit and described more fully in the Permittee's application in which the Permittee shall record the following information:
  - (1) The date and time the point source and any associated treatment or control facilities or systems were inspected by the Permittee;
  - (2) Whether there was a discharge from the point source at the time of inspection by the Permittee;
  - (3) Whether a sample of the discharge from the point source was collected at the time of inspection by the Permittee;



- (4) Whether all associated treatment or control facilities or systems appeared to be in good working order and operating as efficiently as possible, and if not, a description of the problems or deficiencies; and
- (5) The name and signature of the person performing the inspection of the point source and associated treatment or control facilities or systems.

**9. Records Retention and Production**

- a. The Permittee shall retain records of all monitoring information, including all calibration and maintenance records and all original strip chart recordings for continuous monitoring instrumentation, copies of all reports required by this Permit, and records of all data used to complete the above reports or the application for this Permit, for a period of at least three (3) years from the date of the sample collection, measurement, report, or application. This period may be extended by request of the Director at any time. If litigation or other enforcement action, under the AWPCA, AEMA, and/or the FWPCA, is ongoing which involves any of the above records, the records shall be kept until the litigation is resolved. Upon the written request of the Director, the Permittee shall provide the Director with a copy of any record required to be retained by this paragraph. Copies of these records should not be submitted unless requested.
- b. All records required to be kept for a period of three (3) years shall be kept at the permitted facility or an alternate location approved by the Department in writing and shall be available for inspection.

**10. Monitoring Equipment and Instrumentation**

All equipment and instrumentation used to determine compliance with the requirements of this Permit shall be installed, maintained, and calibrated in accordance with the manufacturer's instructions or, in the absence of manufacturer's instructions, in accordance with accepted practices. The Permittee shall develop and maintain quality assurance procedures to ensure proper operation and maintenance of all equipment and instrumentation. The quality assurance procedures shall include the proper use, maintenance, and installation, when appropriate, of monitoring equipment at the plant site.

**D. DISCHARGE REPORTING REQUIREMENTS**

**1. Requirements for Reporting of Monitoring**

- a. Monitoring results obtained during the previous three (3) months shall be summarized for each month on a Discharge Monitoring Report (DMR) Form approved by the Department, and submitted to the Department so that it is received by the Director no later than the 28<sup>th</sup> day of the month following the quarterly reporting period (i.e., on the 28<sup>th</sup> day of January, April, July, and October of each year).
- b. The Department utilizes a web-based electronic reporting system for submittal of DMRs. Except as allowed by Part I.D.1.c. or d., the Permittee shall submit all DMRs required by Part I.D.1.a. by utilizing the Department's current electronic reporting system. The Department's current reporting system, Alabama Environmental Permitting and Compliance System (AEPACS), can be found online at <https://aepacs.adem.alabama.gov/nviro/ncore/external/home>.

- c. If the electronic reporting system is down (i.e. electronic submittal of DMR data is unable to be completed due to technical problems originating with the Department's system; this could include entry/submittal issues with an entire set of DMRs or individual parameters), permittees are not relieved of their obligation to submit DMR data to the Department by the required submittal date. However, if the electronic reporting system is down on the 28th day of the month or is down for an extended period of time as determined by the Department when a DMR is required to be submitted, the facility may submit the data in an alternate manner and format acceptable to the Department. Preapproved alternate acceptable methods include faxing, e-mailing, mailing, or hand-delivery of data such that they are received by the required reporting date. Within five calendar days of the electronic reporting system resuming operation, the Permittee shall enter the data into the reporting system unless an alternate timeframe is approved by the Department. An attachment should be included with the electronic DMR submittal verifying the original submittal date (date of the fax, copy of dated e-mail, or hand-delivery stamped date).
- d. The permittee may submit a request to the Department for a temporary electronic reporting waiver for DMR submittals. The waiver request should include the permit number; permittee name; facility/site name; facility address; name, address, and contact information for the responsible official or duly authorized representative; a detailed statement regarding the basis for requesting such a waiver; and the duration for which the waiver is requested. Approved electronic reporting waivers are not transferrable. Permittees with an approved electronic reporting waiver for DMRs may submit hard copy DMRs for the period that the approved electronic reporting waiver request is effective. The Permittee shall submit the Department-approved DMR forms to the address listed in Part I.D.1.i.
- e. If the Permittee, using approved analytical methods as specified in Part I.C.6., monitors any discharge from a point source identified on Page 1 of this Permit and describe more fully in the Permittee's application more frequently than required by this Permit; the results of such monitoring shall be included in the calculation and reporting of values on the DMR Form, and the increased frequency shall be indicated on the DMR Form.
- f. In the event no discharge from a point source identified on Page 1 of this Permit and described more fully in the Permittee's application occurs during a monitoring period, the Permittee shall report "No Discharge" for such period on the appropriate DMR Form.
- g. Each DMR Form submitted by the Permittee to the Department in accordance with Part I.D.1. must be legible and bear an original signature or electronic signature. Photo and electronic copies of the signature are not acceptable and shall not satisfy the reporting requirements of this Permit.
- h. All reports and forms required to be submitted by this Permit, the AWPCA, and the Department's rules and regulations, shall be signed by a "responsible official" of the Permittee as defined in ADEM Admin. Code r. 335-6-6-.09 or a "duly authorized representative" of such official as defined in ADEM Admin. Code r. 335-6-6-.09 and shall bear the following certification:

"I certify under penalty of law that this document and all attachments were prepared under my direction or supervision in accordance with a system designed to assure that qualified personnel properly gather and evaluate the information submitted. Based on my inquiry of the person or persons who manage the system, or those persons directly responsible for gathering the information, the information submitted is, to the best of my knowledge and belief, true, accurate, and complete. I am aware that there are significant penalties for submitting false information, including the possibility of fine and imprisonment for knowing violations."

- i. All DMRs, reports, and forms required to be submitted by this Permit, the AWPCA and the Department's rules and regulations, shall be submitted through the Department's electronic reporting system, AEPACS, or, if in hardcopy, shall be addressed to:

Alabama Department of Environmental Management  
Water Division, Mining and Natural Resource Section  
Post Office Box 301463  
Montgomery, Alabama 36130-1463

Certified and Registered Mail shall be addressed to:

Alabama Department of Environmental Management  
Water Division, Mining and Natural Resource Section  
1400 Coliseum Boulevard  
Montgomery, Alabama 36110-2059

- j. Unless authorized in writing by the Department, approved reporting forms required by this Permit or the Department are not to be altered, and if copied or reproduced, must be consistent in format and identical in content to the ADEM approved form. Unauthorized alteration, falsification, or use of incorrectly reproduced forms constitutes noncompliance with the requirements of this Permit and may significantly delay processing of any request, result in denial of the request, result in permit termination, revocation, suspension, modification, or denial of a permit renewal application, or result in other enforcement action.
- k. If this Permit is a reissuance, then the Permittee shall continue to submit DMRs in accordance with the requirements of their previous permit until such time as DMRs are due as discussed in Part I.D.1.

**2. Noncompliance Notification**

- a. The Permittee must notify the Department if, for any reason, the Permittee's discharge:
- (1) Potentially threatens human health or welfare;
  - (2) Potentially threatens fish or aquatic life;
  - (3) Causes an in-stream water quality criterion to be exceeded;
  - (4) Does not comply with an applicable toxic pollutant effluent standard or prohibition established under Section 307(a) of the FWPCA, 33 U.S.C. §1317(a);
  - (5) Contains a quantity of a hazardous substance which has been determined may be harmful to the public health or welfare under Section 311(b)(4) of the FWPCA, 33 U.S.C. §1321(b)(4); or
  - (6) Exceeds any discharge limitation for an effluent parameter as a result of an unanticipated bypass or upset.

The Permittee shall orally or electronically report any of the above occurrences, describing the circumstances and potential effects of such discharge to the Director within 24-hours after the Permittee becomes aware of the occurrence of such discharge. In addition to the oral or electronic report, the Permittee shall submit to the Director a written report as

provided in Part I.D.2.c., no later than five (5) days after becoming aware of the occurrence of such discharge.

- b. If for any reason, the Permittee's discharge does not comply with any limitation of this Permit, the Permittee shall submit a written report to the Director as provided in Part I.D.2.c. This report must be submitted with the next Discharge Monitoring Report required to be submitted by Part I.D.1. of this Permit after becoming aware of the occurrence of such noncompliance.
- c. An electronic Noncompliance Notification Form in a Department-approved format must be submitted to the Director in accordance with Parts I.D.2.a. and b. The completed form must document the following information:
  - (1) A description of the discharge and cause of noncompliance;
  - (2) The period of noncompliance, including exact dates and times, or if not corrected, the anticipated time the noncompliance is expected to continue; and
  - (3) A description of the steps taken and/or being taken to reduce or eliminate the noncomplying discharge and to prevent its recurrence.

**3. Reduction, Suspension, or Termination of Monitoring and/or Reporting**

- a. The Director may, with respect to any point source identified on Page 1 of this Permit and described more fully in the Permittee's application, authorize the Permittee to reduce, suspend, or terminate the monitoring and/or reporting required by this Permit upon the submission of a written request for such reduction, suspension, or termination by the Permittee provided:
  - (1) All mining, processing, or disturbance in the drainage basin(s) associated with the discharge has ceased and site access is adequately restricted or controlled to preclude unpermitted and unauthorized mining, processing, transportation, or associated operations/activity;
  - (2) Permanent, perennial vegetation has been re-established on all areas mined or disturbed for at least one year since mining has ceased in the drainage basin(s) associated with the surface discharge, or all areas have been permanently graded such that all drainage is directed back into the mined pit to preclude all surface discharges;
  - (3) Unless waived in writing by the Department, the Permittee has been granted, in writing, a 100% Bond Release, if applicable, by the Alabama Department of Industrial Relations and, if applicable, by the Surface Mining Commission for all areas mined or disturbed in the drainage basin(s) associated with the discharge;
  - (4) Unless waived in writing by the Department, the Permittee has submitted inspection reports prepared and certified by a Professional Engineer (PE) registered in the State of Alabama or a qualified professional under the PE's direction which certify that the facility has been fully reclaimed or that water quality remediation has been achieved. The first inspection must be conducted approximately one year prior to and the second inspection must be conducted within thirty days of the Permittee's request for termination of monitoring and reporting requirements;

- (5) All surface effects of the mining activity such as fuel or chemical tanks, preparation plants or equipment, old tools or equipment, junk or debris, etc., must be removed and disposed of according to applicable state and federal regulations;
  - (6) The Permittee's request for termination of monitoring and reporting requirements contained in this Permit has been supported by monitoring data covering a period of at least six consecutive months or such longer period as is necessary to assure that the data reflect discharges occurring during varying seasonal climatological conditions;
  - (7) The Permittee has stated in its request that the samples collected and reported in the monitoring data submitted in support of the Permittee's request for monitoring termination or suspension are representative of the discharge and were collected in accordance with all Permit terms and conditions respecting sampling times (e.g., rainfall events) and methods and were analyzed in accordance with all Permit terms and conditions respecting analytical methods and procedures;
  - (8) The Permittee has certified that during the entire period covered by the monitoring data submitted, no chemical treatment of the discharge was provided;
  - (9) The Permittee's request has included the certification required by Part I.D.1.e. of this Permit; and
  - (10) The Permittee has certified to the Director in writing as part of the request, its compliance with (1) through (9) above.
- b. It remains the responsibility of the Permittee to comply with the monitoring and reporting requirements of this Permit until written authorization to reduce, suspend, or terminate such monitoring and/or reporting is received by the Permittee from the Director.

## **E. OTHER REPORTING AND NOTIFICATION REQUIREMENTS**

### **1. Anticipated Noncompliance**

The Permittee shall give the Director written advance notice of any planned changes or other circumstances regarding a facility which may result in noncompliance with permit requirements.

### **2. Termination of Discharge**

The Permittee shall notify the Director, in writing, when all discharges from any point source(s) identified on Page 1 of this Permit and described more fully in the Permittee's application have permanently ceased.

### **3. Updating Information**

- a. The Permittee shall inform the Director of any change in the Permittee's mailing address or telephone number or in the Permittee's designation of a facility contact or officer(s) having the authority and responsibility to prevent and abate violations of the AWPCA, the AEMA, the Department's rules and regulations, and the terms and conditions of this Permit, in writing, no later than ten (10) days after such change. Upon request of the Director, the Permittee shall furnish the Director with an update of any information provided in the permit application.

- b. If the Permittee becomes aware that it failed to submit any relevant facts in a permit application, or submitted incorrect information in a permit application or in any report to the Director, it shall promptly submit such facts or information with a written explanation for the mistake and/or omission.

**4. Duty to Provide Information**

- a. The Permittee shall furnish to the Director, within a reasonable time, any information which the Director may request to determine whether cause exists for modifying, suspending, terminating, or revoking and reissuing this Permit, in whole or in part, or to determine compliance with this Permit. The Permittee shall also furnish to the Director upon request, copies of records required to be maintained by this Permit.
- b. The Permittee shall furnish to the Director upon request, within a reasonable time, available information (name, phone number, address, and site location) which identifies offsite sources of material or natural resources (mineral, ore, or other material such as iron, coal, coke, dirt, chert, shale, clay, sand, gravel, bauxite, rock, stone, etc.) used in its operation or stored at the facility.

**F. SCHEDULE OF COMPLIANCE**

The Permittee shall achieve compliance with the discharge limitations specified in Part I.A. of this Permit in accordance with the following schedule:

**Compliance must be achieved by the effective date of this Permit.**

## **PART II OTHER REQUIREMENTS, RESPONSIBILITIES, AND DUTIES**

### **A. OPERATIONAL AND MANAGEMENT REQUIREMENTS**

#### **1. Facilities Operation and Management**

The Permittee shall at all times operate and maintain all facilities and systems of treatment and control (and related appurtenances) which are installed or used by the Permittee to achieve compliance with the conditions of this Permit. Proper operation and maintenance includes effective performance, adequate funding, adequate operator staffing and training, and adequate laboratory and process controls, including appropriate quality assurance procedures. This provision requires the operation of backup or auxiliary facilities only when necessary to achieve compliance with the conditions of this Permit.

#### **2. Pollution Abatement and/or Prevention Plan**

a. The Pollution Abatement and/or Prevention (PAP) Plan shall be prepared and certified by a registered Professional Engineer (PE), licensed to practice in the State of Alabama, and shall include at a minimum:

- (1) The information indicated in ADEM Admin Code r. 335-6-9-.03 and ADEM Admin. Code ch. 335-6-9 and its Appendices A and B;
- (2) A description of methods which will be implemented to prevent offsite vehicle tracking onto roadways and/or into ditches at the entrances and/or exits of the Permittee's operations;
- (3) A description of setbacks from waters of the State in units of linear feet on the horizontal plane; a description of the methods taken to visibly delineate setbacks from waters of the State; and a description of any other actions taken to prevent encroachment upon setbacks;
- (4) A description of the methods used to delineate the boundaries of coverage under this Permit such that the boundaries are readily visible during the life of the operation;
- (5) A description of any other Best Management Practices (BMPs) which will be implemented to provide control of all nonpoint source pollution that is or may be associated with the Permittee's operations;

b. The PAP Plan shall become a part of this Permit and all requirements of the PAP Plan shall become requirements of this Permit pursuant to ADEM Admin Code r. 335-6-9-.05(2). The PAP Plan shall be amended if the Department determines that the existing sediment control measures, erosion control measures, or other site management practices are ineffective or do not meet the requirements of this Permit.

c. For existing sources, the PAP Plan shall be updated to include all requirements of this section within 180 days of the effective date of this permit. New sources shall submit the PAP plan with the NPDES Individual Permit application prior to coverage under this Permit.

#### **3. Best Management Practices (BMPs)**

- a. Unless otherwise authorized in writing by the Director, the Permittee shall provide a means of subsurface withdrawal for any discharge from each point source identified on Page 1 of this Permit and described more fully in the Permittee's application. Notwithstanding the above provision, a means of subsurface withdrawal need not be provided for any discharge caused by a 24-hour precipitation event greater than a 10-year, 24-hour precipitation event.
- b. Dilution water shall not be added to achieve compliance with discharge limitations except when the Director has granted prior written authorization for dilution to meet water quality requirements.
- c. The Permittee shall minimize the contact of water with overburden, including but not limited to stabilizing disturbed areas through grading, diverting runoff, achieving quick growing stands of temporary vegetation, sealing acid-forming and toxic-forming materials, and maximizing placement of waste materials in back-fill areas.
- d. The Permittee shall prepare, submit to the Department for approval, and implement a Best Management Practices (BMPs) Plan for containment of any or all process liquids or solids, in a manner such that these materials do not present a potential for discharge, if so required by the Director. When submitted and approved, the BMP Plan shall become a part of this Permit and all requirements of the BMP Plan shall become requirements of this Permit.
- e. Spill Prevention, Control, and Management

The Permittee shall prepare, implement, and maintain a Spill Prevention, Control and Countermeasures (SPCC) Plan acceptable to the Department that is prepared and certified by a Professional Engineer (PE), registered in the State of Alabama, for all onsite petroleum product or other pollutant storage tanks or containers as provided by ADEM Admin. Code r. 335-6-6-.08(j)5. The Plan shall describe and the Permittee shall implement appropriate structural and/or non-structural spill prevention, control, and/or management pursuant to ADEM Admin. Code r. 335-6-6-.12 (r) sufficient to prevent any spills of pollutants from entering a ground or surface water of the State or a publicly or privately owned treatment works. The Plan shall include at a minimum, the engineering requirements provided in 40 C.F.R. §§112.1. Any containment system used to implement this requirement shall be constructed of materials compatible with the substance(s) contained and shall prevent the contamination of groundwater. Such containment systems shall be capable of retaining a volume equal to 110 percent of the capacity of the largest tank for which containment is provided. The Plan shall list any materials which the Permittee may utilize to contain and to absorb fuel and chemical spills and leaks. The Permittee shall maintain sufficient amounts of such materials onsite or have sufficient amounts of such materials readily available to contain and/or absorb fuel and chemical spills and leaks. Soil contaminated by chemical spills, oil spills, etc., must be immediately cleaned up or be removed and disposed of in a manner consistent with all State and federal regulations.

- f. All surface drainage and storm water runoff which originate within or enters the Permittee's premises and which contains any pollutants or other wastes shall be discharged, if at all, from a point source identified on Page 1 of this Permit and described more fully in the Permittee's application.
- g. The Permittee shall take all reasonable precautions to prevent any surface drainage or storm water runoff which originates outside the Permittee's premises and which contains any pollutants or other wastes from entering the Permittee's premises. At no time shall the Permittee discharge any such surface drainage or storm water runoff which enters the Permittee's premises if, either alone or in combination with the Permittee's effluent, the discharge would exceed any applicable discharge limitation specified in Part I.A. of this Permit.



**4. Biocide Additives**

- a. The Permittee shall notify the Director in writing not later than sixty (60) days prior to instituting the use of any biocide corrosion inhibitor or chemical additive in any cooling or boiler system(s) regulated by this Permit. Notification is not required for additives that should not reasonably be expected to cause the cooling water or boiler water to exhibit toxicity as determined by analysis of manufacturer's data or testing by the Permittee. Such notification shall include:
- (a) Name and general composition of biocide or chemical;
  - (b) 96-hour median tolerance limit data for organisms representative of the biota of the water(s) which the discharge(s) enter(s);
  - (c) Quantities to be used;
  - (d) Frequencies of use;
  - (e) Proposed discharge concentrations; and
  - (f) EPA registration number, if applicable.
- b. The use of any biocide or chemical additive containing tributyl tin, tributyl tin oxide, zinc, chromium, or related compounds in any cooling or boiler system(s) regulated by the Permit is prohibited except as exempted below. The use of a biocide or additive containing zinc, chromium or related compounds may be used in special circumstances if (1) the permit contains limits for these substances, or (2) the applicant demonstrates during the application process that the use of zinc, chromium or related compounds as a biocide or additive will not pose a reasonable potential to violate the applicable State water quality standards for these substances. The use of any additive, not identified in this Permit or in the application for this Permit or not exempted from notification under this Permit is prohibited, prior to a determination by the Department that permit modification to control discharge of the additive is not required or prior to issuance of a permit modification controlling discharge of the additive.

**5. Facility Identification**

The Permittee shall clearly display prior to commencement of any regulated activity and until permit coverage is properly terminated, the name of the Permittee, entire NPDES permit number, facility or site name, and other descriptive information deemed appropriate by the Permittee at an easily accessible location(s) to adequately identify the site, unless approved otherwise in writing by the Department. The Permittee shall repair or replace the sign(s) as necessary upon becoming aware that the identification is missing or is unreadable due to age, vandalism, theft, weather, or other reason.

**6. Removed Substances**

Solids, sludges, filter backwash, or any other pollutants or other wastes removed in the course of treatment or control of wastewaters shall be disposed of in a manner that complies with all applicable Department rules and regulations.

**7. Loss or Failure of Treatment Facilities**

Upon the loss or failure of any treatment facility, including but not limited to the loss or failure of the primary source of power of the treatment facility, the Permittee shall, where necessary to maintain compliance with the discharge limitations specified in Part I.A. of this Permit or any other terms or conditions of this Permit, cease, reduce, or otherwise control production and/or discharges until treatment is restored.

**8. Duty to Mitigate**

The Permittee shall promptly take all reasonable steps to minimize or prevent any violation of this Permit or to mitigate and minimize any adverse impact to waters resulting from noncompliance with any discharge limitation specified in Part I.A. of this Permit, including such accelerated or additional monitoring of the discharge and/or the receiving waterbody as is necessary to determine the nature and impact of the noncomplying discharge.

**B. BYPASS AND UPSET**

**1. Bypass**

a. Any bypass is prohibited except as provided in Parts II.B.1.b. and c.

b. A bypass is not prohibited if:

- (1) It does not cause any applicable discharge limitation specified in Part I.A. of this Permit to be exceeded;
- (2) The discharge resulting from such bypass enters the same receiving water as the discharge from the permitted outfall;
- (3) It is necessary for essential maintenance of a treatment or control facility or system to assure efficient operation of such facility or system; and
- (4) The Permittee monitors the discharge resulting from such bypass at a frequency, at least daily, sufficient to prove compliance with the discharge limitations specified in Part I.A. of this Permit.

c. A bypass is not prohibited and need not meet the discharge limitations specified in Part I.A. of this Permit if:

- (1) It is unavoidable to prevent loss of life, personal injury, or severe property damage;
- (2) There are no feasible alternatives to the bypass, such as the use of auxiliary treatment facilities, retention of untreated wastes, or maintenance during normal periods of equipment downtime. This condition is not satisfied if the Permittee could have installed adequate backup equipment to prevent a bypass which occurred during normal periods of equipment downtime or preventive maintenance; and
- (3) The Permittee submits a written request for authorization to bypass to the Director at least ten (10) days, if possible, prior to the anticipated bypass or within 24 hours of an unanticipated bypass, the Permittee is granted such authorization, and Permittee complies with any conditions imposed by the Director to minimize any adverse impact to waters resulting from the bypass.

- d. The Permittee has the burden of establishing that each of the conditions of Parts II.B.1.b. or c. have been met to qualify for an exception to the general prohibition against bypassing contained in Part II.B.1.a. and an exemption, where applicable, from the discharge limitations specified in Part I.A. of this Permit.

2. Upset

- a. The Permittee may seek to demonstrate that noncompliance with technology-based effluent limits occurred as a result of an upset if the conditions of Part II.B.2.b are met and if the Permittee complies with the conditions provided in Part II.B.2.c.
- b. If the Permittee wishes to establish the affirmative defense of an upset for technology-based effluent limit noncompliance, the Permittee must demonstrate through properly signed, contemporaneous operating logs, or other relevant evidence that:
  - (1) An upset occurred and that the Permittee can identify the specific cause(s) of the upset;
  - (2) The wastewater treatment facility was at the time being properly operated in accordance with Part II.B.d.
  - (3) The Permittee submitted notice of the noncompliance during the upset as required by Part II.B.2.c; and
  - (4) The Permittee complied with any remedial measures required under Part II.A.7. of this Permit.
- c. If the Permittee wishes to establish the affirmative defense of an upset for technology-based effluent limit noncompliance, the Permittee shall:
  - (1) No later than 24-hours after becoming aware of the occurrence of the upset, orally report the occurrence and circumstances of the upset to the Director in accordance with Part I.G.2.; and
  - (2) No later than five (5) days after becoming aware of the occurrence of the upset, furnish the Director with evidence, including properly signed, contemporaneous operating logs, design drawings, construction certification, maintenance records, weir flow measurements, dated photographs, rain gauge measurements, or other relevant evidence, demonstrating that:
    - (i) An upset occurred;
    - (ii) The Permittee can identify the specific cause(s) of the upset;
    - (iii) The Permittee's treatment facility was being properly operated at the time of the upset; and
    - (iv) The Permittee promptly took all reasonable steps to minimize any adverse impact to waters resulting from the upset.
- d. A discharge which is an overflow from a treatment facility or system, or an excess discharge from a point source associated with a treatment facility or system and which results from a 24-hour precipitation event larger than a 10-year, 24-hour precipitation event is not eligible to be considered as a result of an upset unless:

- (1) The treatment facility or system is designed, constructed, and maintained to contain the maximum volume of wastewater which would be generated by the facility during a 24-hour period without an increase in volume from precipitation and the maximum volume of wastewater resulting from a 10-year, 24-hour precipitation event or to treat the maximum flow associated with these volumes. In computing the maximum volume of wastewater which would result from a 10-year, 24-hour precipitation event, the volume which would result from all areas contributing runoff to the individual treatment facility must be included (i.e., all runoff that is not diverted from the mining area and runoff which is not diverted from the preparation plant area); and
  - (2) The Permittee takes all reasonable steps to maintain treatment of the wastewater and minimize the amount of overflow or excess discharge.
- e. The Permittee has the burden of proof in defense of any enforcement action as a result of noncompliance of technology-based effluent limits the Permittee proposes to attribute to an upset.

## **C. PERMIT CONDITIONS AND RESTRICTIONS**

### **1. Prohibition against Discharge from Facilities Not Certified**

- a. Notwithstanding any other provisions of this Permit, if the permitted facility has not obtained or is not required to obtain a permit from the Alabama Surface Mining Commission, any discharge(s) from any point or nonpoint source(s) from the permitted facility which was not certified to the Department on a form approved by the Department by a professional engineer, registered in the State of Alabama, as being designed, constructed, and in accordance with plans and specifications reviewed by the Department is prohibited; or
- b. Notwithstanding any other provisions of this Permit, if the permitted facility has obtained or is required to obtain a permit from the Alabama Surface Mining Commission, any discharge(s) from any point or nonpoint source(s) from the permitted facility which is associated with a treatment facility which was not constructed and certified to the Alabama Surface Mining Commission pursuant to applicable provisions of said Commission's regulations, is prohibited until the Permittee submits to the Alabama Surface Mining Commission, certification by a professional engineer, registered in the State of Alabama, certifying that such facility has been constructed in accordance with plans and specifications approved by the Alabama Surface Mining Commission. This requirement shall not apply to pumped discharges from the underground works of underground coal mines where no surface structure is required by the Alabama Surface Mining Commission, provided the Department is notified in writing of the completion or installation of such facilities, and the pumped discharges will meet permit effluent limits without treatment.

### **2. Permit Modification, Suspension, Termination, and Revocation**

- a. This Permit may be modified, suspended, terminated, or revoked and reissued, in whole or in part, during its term for cause, including but not limited to, the following:
  - (1) The violation of any term or condition of this Permit;

- (2) The obtaining of this Permit by misrepresentation or the failure to disclose fully all relevant facts;
  - (3) The submission of materially false or inaccurate statements or information in the permit application or reports required by the Permit;
  - (4) The need for a change in any condition that requires either a temporary or permanent reduction or elimination of the permitted discharge;
  - (5) The existence of any typographical or clerical errors or of any errors in the calculation of discharge limitations;
  - (6) The existence of material and substantial alterations or additions to the facility or activity generating wastewater which occurred after permit issuance which justify the application of permit conditions that are different or absent in the existing permit;
  - (7) The threat of the Permittee's discharge on human health or welfare; or
  - (8) Any other cause allowed by ADEM Admin. Code ch. 335-6-6.
- b. The filing of a request by the Permittee for modification, suspension, termination, or revocation and reissuance of this Permit, in whole or in part, does not stay any Permit term or condition of this Permit.

**3. Automatic Expiration of Permits for New or Increased Discharges**

- a. Except as provided by ADEM Admin. Code r. 335-6-6-.02(h) and 335-6-6-.05, if this Permit was issued for a new discharger or new source, it shall expire eighteen months after the issuance date if construction has not begun during that eighteen month period.
- b. Except as provided by ADEM Admin. Code r. 335-6-6-.02(h) and 335-6-6-.05, if any portion of this Permit was issued or modified to authorize the discharge of increased quantities of pollutants to accommodate the modification of an existing facility, that portion of this Permit shall expire eighteen months after this Permit's issuance if construction of the modification has not begun within eighteen month period.
- c. Construction has begun when the owner or operator has:
  - (1) Begun, or caused to begin as part of a continuous on-site construction program:
    - (i) Any placement, assembly, or installation of facilities or equipment; or
    - (ii) Significant site preparation work including clearing, excavation, or removal of existing buildings, structures, or facilities which is necessary for the placement, assembly, or installation of new source facilities or equipment; or
  - (2) Entered into a binding contractual obligation for the purpose of placement, assembly, or installation of facilities or equipment which are intended to be used in its operation within a reasonable time. Options to purchase or contracts which can be terminated or modified without substantial loss, and contracts for feasibility, engineering, and design studies do not constitute a contractual obligation under the paragraph. The entering into a lease with the State of

Alabama for exploration and production of hydrocarbons shall also be considered beginning construction.

- d. The automatic expiration of this Permit for new or increased discharges if construction has not begun within the eighteen month period after the issuance of this Permit may be tolled by administrative or judicial stay.

**4. Transfer of Permit**

This Permit may not be transferred or the name of the Permittee changed without notice to the Director and subsequent modification or revocation and reissuance of this Permit to identify the new Permittee and to incorporate any other changes as may be required under the FWPCA or AWPCA. In the case of a change in name, ownership, or control of the Permittee's premises only, a request for permit modification in a format acceptable to the Director is required at least 30 days prior to the change. In the case of a change in name, ownership, or control of the Permittee's premises accompanied by a change or proposed change in effluent characteristics, a complete permit application is required to be submitted to the Director at least 180 days prior to the change. Whenever the Director is notified of a change in name, ownership, or control, he may decide not to modify the existing Permit and require the submission of a new permit application.

**5. Groundwater**

Unless authorized on page 1 of this Permit, this Permit does not authorize any discharge to groundwater. Should a threat of groundwater contamination occur, the Director may require groundwater monitoring to properly assess the degree of the problem, and the Director may require that the Permittee undertake measures to abate any such discharge and/or contamination.

**6. Property and Other Rights**

This Permit does not convey any property rights in either real or personal property, or any exclusive privileges, nor does it authorize any injury to persons or property or invasion of other private rights, trespass, or any infringement of Federal, State, or local laws or regulations, nor does it authorize or approve the construction of any physical structures or facilities or the undertaking of any work in any waters of the State or of the United States.

**D. RESPONSIBILITIES**

**1. Duty to Comply**

- a. The Permittee must comply with all terms and conditions of this Permit. Any permit noncompliance constitutes a violation of the AWPCA, AEMA, and the FWPCA and is grounds for enforcement action, for permit termination, revocation and reissuance, suspension, modification, or denial of a permit renewal application.
- b. The Permittee shall comply with effluent standards or prohibitions established under Section 307(a) of the FWPCA for toxic pollutants within the time provided in the regulations that establish these standards or prohibitions, even if this Permit has not yet been modified to incorporate the effluent standard, prohibition or requirement.
- c. For any violation(s) of this Permit, the Permittee is subject to a civil penalty as authorized by the AWPCA, the AEMA, the FWPCA, and Code of Alabama 1975, §§22-22A-1 et. seq., as amended, and/or a criminal penalty as authorized by Code of Alabama 1975, §22-22-1 et. seq., as amended.

- d. The necessity to halt or reduce production or other activities in order to maintain compliance with the conditions of this Permit shall not be a defense for a Permittee in an enforcement action.
- e. Nothing in this Permit shall be construed to preclude or negate the Permittee's responsibility or liability to apply for, obtain, or comply with other ADEM, federal, state, or local government permits, certifications, licenses, or other approvals.
- f. The discharge of a pollutant from a source not specifically identified in the permit application for this Permit and not specifically included in the description of an outfall in this Permit is not authorized and shall constitute noncompliance with this Permit.
- g. The Permittee shall take all reasonable steps, including cessation of production or other activities, to minimize or prevent any violation of this Permit or to minimize or prevent any adverse impact of any permit violation.

**2. Change in Discharge**

- a. The Permittee shall apply for a permit modification at least 180 days in advance of any facility expansion, production increase, process change, or other action that could result in the discharge of additional pollutants, increase the quantity of a discharged pollutant, or that could result in an additional discharge point. This requirement also applies to pollutants that are not subject to discharge limitations in this Permit. No new or increased discharge may begin until the Director has authorized it by issuance of a permit modification or a reissued permit.
- b. The Permittee shall notify the Director as soon as it knows or has reason to believe that it has begun or expects to begin to discharge any pollutant listed as a toxic pollutant pursuant to Section 307(a) of the FWPCA, 33 U.S.C. §1317(a), any substance designated as a hazardous substance pursuant to Section 311(b)(2) of the FWPCA, 33 U.S.C. §1321(b)(2), any waste listed as a hazardous waste pursuant to Code of Alabama 1975, §22-30-10, or any other pollutants or other wastes which is not subject to any discharge limitations specified in Part I.A. of this Permit and was not reported in the Permittee's application, was reported in the Permittee's application in concentrations or mass rates lower than that which the Permittee expects to begin to be discharged, or has reason to believe has begun to be discharged.

**3. Compliance with Toxic or Other Pollutant Effluent Standard or Prohibition**

If any applicable effluent standard or prohibition (including any schedule of compliance specified in such effluent standard or prohibition) is established under Sections 301(b)(2)(C),(D),(E) and (F) of the FWPCA, 33 U.S.C. §1311(b)(2)(C),(D),(E), and (F); 304(b)(2) of the FWPCA, 33 U.S.C. §1314(b)(2); or 307(a) of the FWPCA, 33 U.S.C. §1317(a), for a toxic or other pollutant discharged by the Permittee, and such standard or prohibition is more stringent than any discharge limitation on the pollutant specified in Part I.A. of this Permit or controls a pollutant not limited in Part I.A. of this Permit, this Permit shall be modified to conform to the toxic or other pollutant effluent standard or prohibition and the Permittee shall be notified of such modification. If this Permit has not been modified to conform to the toxic or other pollutant effluent standard or prohibition before the effective date of such standard or prohibition, the authorization to discharge in this Permit shall be void to the extent that any discharge limitation on such pollutant in Part I.A. of this Permit exceeds or is inconsistent with the established toxic or other pollutant effluent standard or prohibition.

**4. Compliance with Water Quality Standards and Other Provisions**

- a. On the basis of the Permittee's application, plans, or other available information, the Department has determined that compliance with the terms and conditions of this Permit will assure compliance with applicable water quality standards. However, this Permit does not relieve the Permittee from compliance with applicable State water quality standards established in ADEM Admin. Code ch. 335-6-10, and does not preclude the Department from taking action as appropriate to address the potential for contravention of applicable State water quality standards which could result from discharges of pollutants from the permitted facility.
- b. Compliance with Permit terms and conditions notwithstanding, if the Permittee's discharge(s) from point source(s) identified on Page 1 of this Permit cause(s) or contribute(s) to a condition in contravention of State water quality standards, the Department may require abatement action to be taken by the Permittee, modify the Permit pursuant to the Department's rules and regulations, or both.
- c. If the Department determines, on the basis of a notice provided pursuant to Part II.C.2. of this Permit or any investigation, inspection, or sampling, that a modification of this Permit is necessary to assure maintenance of water quality standards or compliance with other provisions of the AWPCA or FWPCA, the Department may require such modification and, in cases of emergency, the Director may prohibit the noticed act until the Permit has been modified.

**5. Compliance with Statutes and Rules**

- a. This Permit has been issued under ADEM Admin. Code div. 335-6. All provisions of this division, that are applicable to this Permit, are hereby made a part of this Permit. A copy of this division may be obtained for a small charge from the Office of General Counsel, Alabama Department of Environmental Management, 1400 Coliseum Blvd., Montgomery, AL 36110-2059.
- b. This Permit does not authorize the noncompliance with or violation of any Laws of the State of Alabama or the United States of America or any regulations or rules implementing such laws. FWPCA, 33 U.S.C. Section 1319, and Code of Alabama 1975, Section 22-22-14.

**6. Right of Entry and Inspection**

The Permittee shall allow the Director, or an authorized representative, upon the presentation of credentials and other documents as may be required by law to:

- a. Enter upon the Permittee's premises where a regulated facility or activity is located or conducted, or where records must be kept under the conditions of the Permit;
- b. Have access to and copy, at reasonable times, any records that must be kept under the conditions of this Permit;
- c. Inspect at reasonable times any facilities, equipment (including monitoring and control equipment), practices, or operations regulated or required under this Permit; and
- d. Sample or monitor at reasonable times, for the purposes of assuring Permit compliance or as otherwise authorized by the AWPCA, any substances or parameters at any location.

**7. Duty to Reapply or Notify of Intent to Cease Discharge**



- a. If the Permittee intends to continue to discharge beyond the expiration date of this Permit, the Permittee shall file with the Department a complete permit application for reissuance of this Permit at least 180 days prior to its expiration. Applications must be submitted electronically via the Department's current electronic permitting system. The Department's current online permitting system, Alabama Environmental Permitting and Compliance System (AEPACS), can be found online at <https://aepacs.adem.alabama.gov/nviro/ncore/external/home>.
- b. If the Permittee does not desire to continue the discharge(s) allowed by this Permit, the Permittee shall notify the Department at least 180 days prior to expiration of this Permit of the Permittee's intention not to request reissuance of this Permit. This notification must include the information required in Part I.D.4.a. and be signed by an individual meeting the signatory requirements for a permit application as set forth in ADEM Admin. Code r. 335-6-6-.09.
- c. Failure of the Permittee to submit to the Department a complete application for reissuance of this Permit at least 180 days prior to the expiration date of this Permit will void the automatic continuation of this Permit provided by ADEM Admin. Code r. 335-6-6-.06; and should this Permit not be reissued for any reason, any discharge after the expiration of this Permit will be an unpermitted discharge.

## **PART III ADDITIONAL REQUIREMENTS, CONDITIONS, AND LIMITATIONS**

### **A. CIVIL AND CRIMINAL LIABILITY**

#### **1. Tampering**

Any person who falsifies, tampers with, or knowingly renders inaccurate any monitoring device or method required to be maintained or performed under this Permit shall, upon conviction, be subject to penalties and/or imprisonment as provided by the AWPCA and/or the AEMA.

#### **2. False Statements**

Any person who knowingly makes any false statement, representation, or certification in any record or other document submitted or required to be maintained under this Permit, including monitoring reports or reports of compliance or noncompliance shall, upon conviction, be punished as provided by applicable State and Federal law.

#### **3. Permit Enforcement**

This NPDES Permit is a Permit for the purpose of the AWPCA, the AEMA, and the FWPCA, and as such all terms, conditions, or limitations of this Permit are enforceable under State and Federal law.

#### **4. Relief From Liability**

Except as provided in Part II.B.1. (Bypass) and Part II.B.2. (Upset), nothing in this Permit shall be construed to relieve the Permittee of civil or criminal liability under the AWPCA, AEMA, or FWPCA for noncompliance with any term or condition of this Permit.

### **B. OIL AND HAZARDOUS SUBSTANCE LIABILITY**

Nothing in this Permit shall be construed to preclude the institution of any legal action or relieve the Permittee from any responsibilities, liabilities, or penalties to which the Permittee is or may be subject to under Section 311 of the FWPCA, 33 U.S.C. §1321.

### **C. AVAILABILITY OF REPORTS**

Except for data determined to be confidential under Code of Alabama 1975, §22-22-9(c), all reports prepared in accordance with the terms of this Permit shall be available for public inspection at the offices of the Department. Effluent data shall not be considered confidential. Knowingly making any false statement in any such report may result in the imposition of criminal penalties as provided for in Section 309 of the FWPCA, 33 U.S.C. §1319, and Code of Alabama 1975, §22-22-14.

### **D. DEFINITIONS**

1. Alabama Environmental Management Act (AEMA) - means Code of Alabama 1975, §§22-22A-1 et. seq., as amended.
2. Alabama Water Pollution Control Act (AWPCA) - means Code of Alabama 1975, §§22-22-1 et. seq., as amended.
3. Average monthly discharge limitation - means the highest allowable average of "daily discharges" over a calendar month, calculated as the sum of all "daily discharges" measured during a calendar

month divided by the number of "daily discharges" measured during that month (zero discharge days shall not be included in the number of "daily discharges" measured and a less than detectable test result shall be treated as a concentration of zero if the most sensitive EPA approved method was used).

4. Arithmetic Mean - means the summation of the individual values of any set of values divided by the number of individual values.
5. BOD - means the five-day measure of the pollutant parameter biochemical oxygen demand
6. Bypass - means the intentional diversion of waste streams from any portion of a treatment facility.
7. CBOD - means the five-day measure of the pollutant parameter carbonaceous biochemical oxygen demand.
8. Controlled Surface Mine Drainage – means any surface mine drainage that is pumped or siphoned from the active mining area.
9. Daily discharge - means the discharge of a pollutant measured during any consecutive 24-hour period in accordance with the sample type and analytical methodology specified by the discharge permit.
10. Daily maximum - means the highest value of any individual sample result obtained during a day.
11. Daily minimum - means the lowest value of any individual sample result obtained during a day.
12. Day - means any consecutive 24-hour period.
13. Department - means the Alabama Department of Environmental Management.
14. Director - means the Director of the Department or his authorized representative or designee.
15. Discharge - means "[t]he addition, introduction, leaking, spilling or emitting of any sewage, industrial waste, pollutant or other waste into waters of the state." Code of Alabama 1975, §22-22-1(b)(8).
16. Discharge monitoring report (DMR) - means the form approved by the Director to accomplish monitoring report requirements of an NPDES Permit.
17. DO - means dissolved oxygen.
18. E. coli – means the pollutant parameter Escherichia coli.
19. 8HC - means 8-hour composite sample, including any of the following:
  - a. The mixing of at least 5 equal volume samples collected at constant time intervals of not more than 2 hours over a period of not less than 8 hours between the hours of 6:00 a.m. and 6:00 p.m. If the sampling period exceeds 8 hours, sampling may be conducted beyond the 6:00 a.m. to 6:00 p.m. period.
  - b. A sample continuously collected at a constant rate over period of not less than 8 hours between the hours of 6:00 a.m. and 6:00 p.m. If the sampling period exceeds 8 hours, sampling may be conducted beyond the 6:00 a.m. to 6:00 p.m. period.
20. EPA - means the United States Environmental Protection Agency.

21. Federal Water Pollution Control Act (FWPCA) - means 33 U.S.C. §§1251 et. seq., as amended.
22. Flow – means the total volume of discharge in a 24-hour period.
23. Geometric Mean - means the Nth root of the product of the individual values of any set of values where N is equal to the number of individual values. The geometric mean is equivalent to the antilog of the arithmetic mean of the logarithms of the individual values. For purposes of calculating the geometric mean, values of zero (0) shall be considered one (1).
24. Grab Sample - means a single influent or effluent portion which is not a composite sample. The sample(s) shall be collected at the period(s) most representative of the discharge.
25. Indirect Discharger - means a nondomestic discharger who discharges pollutants to a publicly owned treatment works or a privately owned treatment facility operated by another person.
26. Industrial User - means those industries identified in the Standard Industrial Classification manual, Bureau of the Budget 1967, as amended and supplemented, under the category “Division D – Manufacturing” and such other classes of significant waste producers as, by regulation, the Director deems appropriate.
27. mg/L - means milligrams per liter of discharge.
28. MGD - means million gallons per day.
29. Monthly Average - means, other than for E. coli bacteria, the arithmetic mean of all the composite or grab samples taken for the daily discharges collected in one month period. The monthly average for E. coli bacteria is the geometric mean of daily discharge samples collected in a one month period. The monthly average for flow is the arithmetic mean of all flow measurements taken in a one month period. (Zero discharges shall not be included in the calculation of monthly averages.)
30. New Discharger - means a person owning or operating any building, structure, facility or installation:
  - a. From which there is or may be a discharge of pollutants;
  - b. From which the discharge of pollutants did not commence prior to August 13, 1979, and which is not a new source; and
  - c. Which has never received a final effective NPDES Permit for dischargers at that site.
31. New Source - means:
  - a. A new source as defined for coal mines by 40 CFR Part 434.11 (1994); and
  - b. Any building, structure, facility, or installation from which there is or may be a discharge of pollutants, the construction of which commenced:
    - (1) After promulgation of standards of performance under Section 306 of FWPCA which are applicable to such source; or
    - (2) After proposal of standards of performance in accordance with Section 306 of the FWPCA which are applicable to such source, but only if the standards are promulgated in accordance with Section 206 within 120 days of their proposal.
32. NH<sub>3</sub>-N - means the pollutant parameter ammonia, measured as nitrogen.

33. 1-year, 24-hour precipitation event - means the maximum 24-hour precipitation event with a probable recurrence interval of once in one year as defined by the National Weather Service and Technical Paper No. 40, "Rainfall Frequency Atlas of the U.S.," May 1961, or equivalent regional or rainfall probability information developed therefrom.
34. Permit application - means forms and additional information that are required by ADEM Admin. Code r. 335-6-6-.08 and applicable permit fees.
35. Point Source - means "any discernible, confined and discrete conveyance, including but not limited to any pipe, channel, ditch, tunnel, conduit, well, discrete fissure, container, rolling stock, concentrated animal feeding operation, or vessel or other floating craft from which pollutants are or may be discharged." Section 502(14) of the FWPCA, 33 U.S.C. §1362(14).
36. Pollutant - includes for purposes of this Permit, but is not limited to, those pollutants specified in Code of Alabama 1975, §22-22-1(b)(3) and those effluent characteristics, excluding flow, specified in Part I.A. of this Permit.
37. Pollutant of Concern - means those pollutants for which a water body is listed as impaired or which contribute to the listed impairment.
38. Pollution Abatement and/or Prevention Plan (PAP Plan) – mining operations plan developed to minimize impacts on water quality to avoid a contravention of the applicable water quality standards as defined in ADEM Admin. Code r. 335-6-9-.03
39. Preparation, Dry - means a dry preparation facility within which the mineral/material is cleaned, separated, or otherwise processed without use of water or chemical additives before it is shipped to the customer or otherwise utilized. A dry preparation plant includes all ancillary operations and structures necessary to clean, separate, or otherwise process the mineral/material, such as storage areas and loading facilities. Dry preparation also includes minor water spray(s) used solely for dust suppression on equipment and roads to minimize dust emissions.
40. Preparation, Wet - means a wet preparation facility within which the mineral/material is cleaned, separated, or otherwise processed using water or chemical additives before it is shipped to the customer or otherwise utilized. A wet preparation plant includes all ancillary operations and structures necessary to clean, separate, or otherwise process the mineral/material, such as storage areas and loading facilities. Wet preparation also includes mineral extraction/processing by dredging, slurry pumping, etc.
41. Privately Owned Treatment Works - means any devices or system which is used to treat wastes from any facility whose operator is not the operator of the treatment works, and which is not a "POTW".
42. Publicly Owned Treatment Works (POTW) - means a wastewater collection and treatment facility owned by the State, municipality, regional entity composed of two or more municipalities, or another entity created by the State or local authority for the purpose of collecting and treating municipal wastewater.
43. Receiving Stream - means the "waters" receiving a "discharge" from a "point source".
44. Severe property damage - means substantial physical damage to property, damage to the treatment facilities which causes them to become inoperable, or substantial and permanent loss of natural resources which can reasonably be expected to occur in the absence of a bypass. Severe property damage does not mean economic loss caused by delays in production.
45. 10-year, 24-hour precipitation event - means that amount of precipitation which occurs during the maximum 24-hour precipitation event with a probable recurrence interval of once in ten years as

defined by the National Weather Service and Technical Paper No. 40, "Rainfall Frequency Atlas of the U.S.," May 1961, or equivalent regional or rainfall probability information developed therefrom.

46. TKN - means the pollutant parameter Total Kjeldahl Nitrogen.
47. TON - means the pollutant parameter Total Organic Nitrogen.
48. TRC - means Total Residual Chlorine.
49. TSS – means the pollutant parameter Total Suspended Solids
50. Treatment facility and treatment system - means all structures which contain, convey, and as necessary, chemically or physically treat mine and/or associated preparation plant drainage, which remove pollutants limited by this Permit from such drainage or wastewater. This includes all pipes, channels, ponds, tanks, and all other equipment serving such structures.
51. 24HC - means 24-hour composite sample, including any of the following:
  - a. The mixing of at least 12 equal volume samples collected at constant time intervals of not more than 2 hours over a period of 24 hours;
  - b. A sample collected over a consecutive 24-hour period using an automatic sampler composite to one sample. As a minimum, samples shall be collected hourly and each shall be no more than one twenty-fourth (1/24) of the total sample volume collected; or
  - c. A sample collected over a consecutive 24-hour period using an automatic composite sampler composited proportional to flow.
52. 24-hour precipitation event - means that amount of precipitation which occurs within any 24-hour period.
53. 2-year, 24-hour precipitation event - means the maximum 24-hour precipitation event with a probable recurrence interval of once in two years as defined by the National Weather Service and Technical Paper No. 40, "Rainfall Frequency Atlas of the U.S.," May 1961, or equivalent regional or rainfall probability information developed therefrom.
54. Upset - means an exceptional incident in which there is an unintentional and temporary noncompliance with technology-based permit discharge limitations because of factors beyond the control of the Permittee. An upset does not include noncompliance to the extent caused by operational error, improperly designed treatment facilities, inadequate facilities, lack of preventive maintenance, or careless or improper operation.
55. Waters - means "[a]ll waters of any river, stream, watercourse, pond, lake, coastal, ground or surface water, wholly or partially within the State, natural or artificial. This does not include waters which are entirely confined and retained completely upon the property of a single individual, partnership, or corporation unless such waters are used in interstate commerce." Code of Alabama 1975, §22-22-1(b)(2). "Waters" include all "navigable waters" as defined in §502(7) of the FWPCA, 33 U.S.C. §1362(7), which are within the State of Alabama.
56. Week - means the period beginning at twelve midnight Saturday and ending at twelve midnight the following Saturday.
57. Weekly (7-day and calendar week) Average – is the arithmetic mean of all samples collected during a consecutive 7-day period or calendar week, whichever is applicable. The calendar week is defined as beginning on Sunday and ending on Saturday. Weekly averages shall be calculated for all calendar weeks with Saturdays in the month. If a calendar week overlaps two months (i.e., the

Sunday is in one month and the Saturday in the following month), the weekly average calculated for the calendar week shall be included in the data for the month that contains the Saturday.

#### **E. SEVERABILITY**

The provisions of this Permit are severable, and if any provision of this Permit or the application of any provision of this Permit to any circumstance, is held invalid, the application of such provision to other circumstances, and the remainder of this Permit, shall not be affected thereby.

#### **F. PROHIBITIONS AND ACTIVITIES NOT AUTHORIZED**

1. Discharges from disposal or landfill activities as described in ADEM Admin. Code div. 335-13 are not authorized by this Permit unless specifically approved by the Department.
2. Relocation, diversion, or other alteration of a water of the State is not authorized by this Permit unless specifically approved by the Department.
3. Lime or cement manufacturing or production and discharge of process waters from such manufacturing or production is not authorized by this Permit unless specifically approved by the Department.
4. Concrete or asphalt manufacturing or production and discharge of process waters from such manufacturing or production is not authorized by this Permit unless specifically approved by the Department.
5. The discharge of wastewater, generated by any process, facility, or by any other means not under the operational control of the Permittee or not identified in the application for this Permit or not identified specifically in the description of an outfall in this Permit is not authorized by this Permit.

#### **G. DISCHARGES TO IMPAIRED WATERS**

1. This Permit does not authorize new sources or new discharges of pollutants of concern to impaired waters unless consistent with an EPA-approved or EPA-established Total Maximum Daily Load (TMDL) and applicable State law, or unless compliance with the limitations and requirements of the Permit ensure that the discharge will not contribute to further degradation of the receiving stream. Impaired waters are those that do not meet applicable water quality standards and are identified on the State of Alabama's §303(d) list or on an EPA-approved or EPA-established TMDL. Pollutants of concern are those pollutants for which the receiving water is listed as impaired or contribute to the listed impairment.
2. Facilities that discharge into a receiving stream which is listed on the State of Alabama's §303(d) list of impaired waters, and with discharges that contain the pollutant(s) for which the waters are impaired, must within six (6) months of the Final §303(d) list approval, document in its BMP plan how the BMPs will control the discharge of the pollutant(s) of concern, and must ensure that there will be no increase of the pollutants of concern. A monitoring plan to assess the effectiveness of the BMPs in achieving the allocations must also be included in the BMP plan.
3. If the facility discharges to impaired waters as described above, it must determine whether a TMDL has been developed and approved or established by EPA for the listed waters. If a TMDL is approved or established during this Permit cycle by EPA for any waters into which the facility discharges, the facility must review the applicable TMDL to see if it includes requirements for control of any water discharged by the Permittee. Within six (6) months of the date of TMDL approval or establishment, the facility must notify the Department on how it will modify its BMP plan to include best management practices specifically targeted to achieve the allocations prescribed

by the TMDL, if necessary. Any revised BMP plans must be submitted to the Department for review. The facility must include in the BMP plan a monitoring component to assess the effectiveness of the BMPs in achieving the allocations.



**ALABAMA DEPARTMENT OF ENVIRONMENTAL MANAGEMENT  
WATER DIVISION**

**NPDES INDIVIDUAL PERMIT RATIONALE**

**Company Name:** Tremedous Stone, LLC

**Facility Name:** Rocky Mountain Quarry

**County:** Blount

**Permit Number:** AL0083950

**Prepared by:** Skylar Wilson

**Date:** March 16, 2026

**Receiving Waters:** Unnamed Tributary to Calvert Prong, Groundwater

**Permit Coverage:** Sandstone Quarry, Mineral Loading, Mineral Storage, Mineral Transportation, and Associated Areas

**SIC Code:** 3281

The Department has made a tentative determination that the available information is adequate to support reissuance and modification of this permit. The modification addresses the relocation of Outfall 001.

This proposed permit covers a sandstone quarry, mineral loading, mineral storage, mineral transportation, and associated areas which discharge to surface waters of the state.

The proposed permit authorizes treated discharges into a stream segment, other State water, or local watershed classified as Fish & Wildlife (F&W) per ADEM Admin. Code ch. 335-6-11. Discharges, however, are within a 24-hour travel period to Calvert Prong classified as Public Water Supply (PWS); therefore, the permit was prepared with consideration given to the higher use classification. If the requirements of the proposed permit are fully implemented, the facility will not discharge pollutants at levels that will cause or contribute to a violation of the F&W and PWS classifications.

Full compliance with the proposed permit terms and conditions is expected to be protective of instream water quality and ensure consistency with applicable instream State water quality standards (WQS) for the receiving stream.

Technology Based Effluent Limits (TBELs) for crushed stone mining facilities can be found in 40 CFR 436.22(1) and (2) for facilities that recycle waste water for use in processing and mine dewatering, respectively. The TBELs were promulgated for existing dischargers using the Best Practicable Control Technology Available (BPT). New Source Performance Standards (NSPS) have not yet been developed by the EPA for the Crushed Stone Subcategory.

The proposed permit includes discharges to Groundwater. Monitoring for discharges to groundwater is not required because of the natural treatment provided by the sandstone formation; however, discharges to surface waters must be monitored twice per month.

NPDES Permit No. AL0083950

The instream WQS for pH, for streams classified as Public Water Supply, are 6.0 - 8.5 s.u per ADEM Admin Code r. 335-6-10-.09. Information provided in the Permittee's application indicated that Outfall 001-1 could discharge chronically when the discharge/stream flow ratio may be high; therefore, discharge limitations for pH of 6.0 – 8.5 s.u. are proposed for Outfall 001 -1 per ADEM Admin Code r. 335-6-10-.09.

The TBELs for 40 CFR 436 Subpart B do not include limitations for Total Suspended Solids (TSS). TSS is classified as a conventional pollutant in 40 CFR 401.16 and is expected to be discharged from this type of facility. Therefore, monthly average and daily maximum effluent limitations for TSS are those proposed by the EPA for crushed stone mine drainage in the *Development Document for Effluent Limitations Guidelines and New Source Performance Standards for the Mineral Mining and Processing Point Source Category* (July 1979).

The applicant has requested, in accordance with 40 CFR Part 122.21 and their NPDES permit application, a waiver from testing for the Part A, B, and C pollutants listed in the EPA Form 2C and 2D that are not addressed in their application. They have also certified that due to the processes involved in their mining activity these pollutants are believed to be not present in the waste stream.

The Pollution Abatement/Prevention (PAP) plan for this facility has been prepared by a professional engineer (PE) registered in the State of Alabama and is designed to ensure reduction of pollutants in the waste stream to a level that, if operated properly, the discharge will not contribute to or cause a violation of applicable State WQS. The proposed permit terms and conditions are predicated on the basis of ensuring a reduction of pollutants in the discharge to a level that reduces the potential of contributing to or causing a violation of applicable State WQS.

In accordance with ADEM Admin. Code r. 335-6-3-.07 the design PE, as evidenced by their seal and/or signature on the application, has accepted full responsibility for the effectiveness of the waste treatment facility to treat the Permittee's effluent to meet NPDES permit limitations and requirements, and to fully comply with Alabama's WQS, when such treatment facilities are properly operated.

If there is a reasonable potential that a pollutant present in the treated discharges from a facility could cause or contribute to a contravention of applicable State WQS above numeric or narrative criteria, 40 CFR Part 122 requires the Department to establish effluent limits using calculated water quality criterion, establish effluent limits on a case-by-case basis using criteria established by EPA, or establish effluent limits based on an indicator parameter. Based on available information, potential pollutants discharged from this facility, if discharged within the concentrations allowed by this permit, would not have a reasonable potential to cause or contribute to a contravention of applicable State WQS.

Pursuant to ADEM Admin. Code r. 335-6-6-.12(r) this permit requires the Permittee to design and implement a Spill Prevention Control and Countermeasures (SPCC) plan for all stored chemicals, fuels and/or stored pollutants that have the potential to discharge to a water of the State. This plan must meet the minimum engineering requirements as defined in 40 CFR Part 112 and must provide for secondary containment adequate to control a potential spill.

The applicant is not proposing discharges of pollutants to a water of the State with an approved Total Maximum Daily Load (TMDL).

The applicant is not proposing discharges into a stream segment or other State water that is included on Alabama's current CWA §303(d) list.

The applicant is not proposing new discharges of pollutant(s) to an ADEM identified Tier I water.

NPDES Permit No. AL0083950

The proposed permit does not authorize new or increased discharges of pollutants to a Tier II water. Therefore, the Antidegradation Policy (ADEM Admin. Code 335-6-10-.04) does not apply to this permit.

# NPDES Individual Permit - Modification/Reissuance - Mining (Form 315)

version 4.9

(Submission #: HQ8-0Z5Z-WYWF8, version 3)

## Details

---

**Submission ID** HQ8-0Z5Z-WYWF8

## Form Input

---

### General Instructions

NPDES Individual Application - Mining and Coalbed Methane Operations - Mod/Reissuance (Form 315/549)

PLEASE CONTACT YOUR ASSIGNED PERMIT CONTACT TO DISCUSS THE TYPE OF MODIFICATION YOU SHOULD APPLY FOR BEFORE COMPLETING THIS FORM.

This form should be used to submit the following permit requests for individually permitted Mining and Coalbed Methane Operations:

Modifications/Reissuances that include Permit Transfers and/or Permittee/Facility Name Changes

Minor Modifications

Major Modifications

Reissuances

Reissuance of a permit on or after the current permit's expiration date

Revocation and Reissuance before the current permit's expiration date

Please complete all questions and attach all necessary documentation as prompted throughout the application process. Incomplete or incorrect information will delay processing.

Applicable Fees:

Minor Modifications

\$3,400 (Mineral/Resource Extraction Mining, Storage Transloading, Dry Processing)

\$3,940 (Wet Preparation, Processing, Beneficiation)

\$3,940 (Coalbed Methane Operations)

Major Modifications

\$5,820 (Mineral/Resource Extraction Mining, Storage Transloading, Dry Processing)

\$6,860 (Wet Preparation, Processing, Beneficiation)

\$6,860 (Coalbed Methane Operations)

Reissuances

\$5,820 (Mineral/Resource Extraction Mining, Storage Transloading, Dry Processing)

\$6,860 (Wet Preparation, Processing, Beneficiation)

\$6,860 (Coalbed Methane Operations)

Potential Add-on Fees for Major Modifications and Reissuances

\$1,015 (Biomonitoring & Toxicity Limits)

\$2,705 (Review of Model Performed by Others)

\$4,855 (Modeling – desktop)

[For assistance, please click here to determine the permit staff responsible for the site or call \(334\) 394-4372.](#)

### Processing Information

#### **Purpose of Application**

Reissuance of Permit Due to Approaching Expiration

**Please indicate if the Permittee is applying for a permit transfer and/or name change in addition to permit modification or reissuance:**

None

**Action Type**

Reissuance

**Briefly describe any planned changes at the facility that are included in this reissuance application:**

Update spillway design on Outfall 001P and submit application for permit renewal.

**Is this a coalbed methane operation?**

No

**Permit Information****Permit Number**

AL0083950

**Current Permittee Name**

Tremedous Stone, LLC

**Permittee****Permittee Name**

Tremedous Stone, LLC

**Mailing Address**

PO BOX 1786

ONEONTA, AL 35121

**Responsible Official****Prefix**

Mr.

**First Name      Last Name**

Eduardo      Mejia

**Title**

Owner/Manager

**Organization Name**

Tremedous Stone, LLC

**Phone Type      Number      Extension**

Business      2054465363

**Email**

tremedousstone@gmail.com

**Mailing Address**

PO BOX 1786

ONEONTA, AL 35121

**Existing Permit Contacts**

Affiliation Type	Contact Information	Remove?
Facility Contact,Notification Recipient,Responsible Official	Eduardo Mejia, Tremedous Stone, LLC	Keep
Application Preparer,Professional Engineer,Notification Recipient,Consultant	Jerry Williams, TASK Engineering Management Inc.	Keep
Permittee,Notification Recipient,Applicant	Tremedous Stone, LLC	Keep

**Facility/Operations Information****Facility/Operations Name**

Rocky Mountain Quarry

**Permittee Organization Type**

LLC

**Parent Corporation and Subsidiary Corporations of Applicant, if any:**

None

**Landowner(s) Name, Address and Phone Number:**

Mr. Eduardo Mejia, 33750 Highway 75, Oneonta, AL 35121, 205-446-5363

**Sub-contractor(s)/Operator(s), if known:**

N/A

**Is the Company/Permittee properly registered and in good standing with the Alabama Secretary of State's office?**

Yes

**Facility/Operations Address or Location Description**

76 Rocky Mountain Road

Oneonta, AL 35121

**Facility/Operations County (Front Gate)**

Blount

**Do the operations span multiple counties?**

No

**Detailed Directions to the Facility/Operations**

From Oneonta take State Hwy 75 north 4.9 miles, turn right on Rocky Mountain Road, proceed 0.2 miles, site is on the right, east of Rocky Mountain Road.

**Please refer to the link below for Lat/Long map instruction help:**

[Map Instruction Help](#)

**Facility/Operations Front Gate Latitude and Longitude**

34.01008600000000,-86.44642800000000

76 Rocky Mountain Road, Oneonta, AL

**Township(s), Range(s), Section(s) (Note: If you are submitting multiple TRSs, please separate each TRS by a semicolon.**

**Example: T19S,R1E,S15; T20S,R2E,S16)**

T12S, R2E, S9; T12S, R2E, S9

**CORRECTION REQUEST (APPROVED)**

**Section Correction**

Include T12S, R2E, S8 in addition to T12S, R2E, S9. Both of those sections are in the topo map permitted area.

Created on 4/22/2025 8:26 AM by **Skylar Wilson**

**SIC Code(s) [Please select your primary SIC code first]:**

3281-Cut Stone and Stone Products

**NAICS Code(s) [Please select your primary NAICS code first]:**

212311-Dimension Stone Mining and Quarrying

**Facility/Operations Contact****Prefix**

Mr.

**First Name      Last Name**

Eduardo      Mejia

**Title**

Owner/Manager

**Organization Name**

Tremendous Stone, LLC

**Phone Type      Number      Extension**

Business      205-446-5363

**Email**

tremendousstone@gmail.com

**Member Information**

Identify the name, title/position, and unless waived in writing by the Department, the resident address of every officer (a PO Box is not acceptable), general partner, LLP partner, LLC member, investor, director, or person performing a function similar to a director, of the applicant, and each person who is the record or beneficial owner of 10 percent or more of any class of voting stock of the applicant, or any other responsible official(s) of the applicant with legal or decision making responsibility or authority for the facility/operations (if this does not apply, then enter N/A after selecting "Manually Enter in Table"):

**List of Names/Titles/Addresses will be entered by:**

Manually Entering in Table

Name	Title/Position	Physical Address of Residence
Eduardo Mejia	Owner/Manager	33750 Highway 75, Oneonta, AL 35121

Other than the "Company/Permittee", identify the name of each corporation, partnership, association, and single proprietorship for which any individual identified above is or was an officer, general partner, LLP partner, LLC member, investor, director, or individual performing a function similar to a director, or principal (10% or more) stockholder, that had an Alabama NPDES permit at any time during the five year (60 month) period immediately preceding the date on which this form is signed (if this does not apply, then enter N/A after selecting "Manually Enter in Table"):

**List of Corporations/Partnerships/etc, Names and Titles will be entered by:**

Manually Entering in Table

Name of Corporation, Partnership, Association, or Single Proprietorship	Name of Individual	Title/Position in Corporation, Partnership, Association, or Single Proprietorship
N/A	N/A	N/A

**Additional Contacts (1 of 1)****ADDITIONAL CONTACTS: Consultant****Contact Type**

Consultant

## Contact

**First Name      Last Name**

Jerry                  Williams

**Title**

Professional Engineer

**Organization Name**

TASK Engineering Management Inc.

**Phone Type      Number              Extension**

Business              2059785070

**Email**

jerryw@taskemi.com

**Address**2832 MONTE DESTE DR  
VESTAVIA HLS, AL 35216

## Compliance History

Has the applicant ever had any of the following:

Event	Apply?
An Alabama NPDES, SID, or UIC permit suspended or terminated	No
An Alabama or federal environmental permit suspended/terminated	No
An Alabama State Oil Gas Board permit or other approval suspended or terminated	No
An Alabama or federal performance/environmental bond, or similar security deposited in lieu of a bond, or portion thereof, forfeited	No

Has the applicant, parent corporation, subsidiary, general partner, LLP partner, or LLC Member had any Warning Letters, Notice of Violations (NOVs), Administrative Actions, or litigation filed by ADEM or EPA during the three year (36 month) period preceding the date on which this form is signed?

Yes

Identify every Warning Letter, Notice of Violation (NOV), Administrative Action, or litigation issued to the applicant, parent corporation, subsidiary, general partner, LLP partner, or LLC Member and filed by ADEM or EPA during the three year (36 month) period preceding the date on which this form is signed.

Date of Issuance	Type of Action	Briefly describe alleged violations:	Date of Final Resolution
04/25/2022	Warning Letter	Tremendous Pit - Failure to display an adequate site sign.	06/13/2022
05/04/2022	Warning Letter	Rocky Mountain Quarry - Failure to display an adequate site sign. PAP not followed - sed. basins	09/30/2022

For this facility, list any other NPDES or other environmental permits (including permit numbers), authorizations, or certifications that have been applied for or issued within the State by ADEM, EPA, Alabama Department of Labor (ADOL), US Army Corp of Engineers (USACE), or other agency, to the applicant, parent corporation, subsidiary, or LLC member whether presently effective, expired, suspended, revoked, or terminated:

N/A

For other facilities, list any other NPDES or other ADEM permits (including permit numbers), authorizations, or certifications that have been applied for or issued within the State by ADEM, EPA, ASMC, ADOL, or USACE, to the applicant, parent corporation, subsidiary, or LLC member whether presently effective, expired, suspended, revoked, or terminated:

Tremendous Pit - NPDES AL0083542, Tremendous Stone Stockyard - NPDES ALR10BBHY

## Anti-Degradation Evaluation



Pursuant to ADEM Admin. Code ch. 335-6-10-.12(9), responses to the following questions must be provided by the applicant requesting NPDES permit coverage for new or expanded discharges of pollutant(s) to Tier 2 waters (except discharges eligible for coverage under general permits). As part of the permit application review process, the Department is required to consider, based on the applicant's demonstration, whether the proposed new or increased discharge to Tier 2 waters is necessary for important economic or social development in the area in which the waters are located. Does this modification/reissuance include new or expanded discharges to Tier II water(s)?  
No

## Activity Description & Information

### Narrative description of activity(s):

Quarrying, Sizing and Classification of Decorative Sandstone

### Total Facility/Operations Area (acres)

35.27

### Total Disturbed Area (acres)

29.25

### Anticipated Commencement Date

12/05/2024

### Anticipated Completion Date

11/30/2029

### Please identify which of the following apply to this operation:

Activity/Condition	Appy?
An existing facility/operation which currently results in discharges to State waters?	Yes
A proposed facility/operation which will result in a discharge to State waters?	No
Be located within any 100-year flood plain?	No
Discharge to Municipal Separate Storm Sewer?	No
Discharge to waters of or be located in the Coastal Zone?	No
Need/have ADEM UIC permit coverage?	No
Be located on Indian/historically significant lands?	No
Need/have ADEM SID permit coverage?	No
Need/have ASMC permit coverage?	No
Need/have State Oil & Gas Board permit coverage?	No
Need/have ADOL permit coverage?	Yes
Generate, treat, store, or dispose of hazardous or toxic waste?	No
Be located in or discharge to a Public Water Supply (PWS) watershed or be located within 1/4 mile of any PWS well?	No
Incised pit	Yes

### Does your facility/operation use cooling water?

No

## Material to be Removed, Processed, or Transloaded

### Material To Be Removed, Processed, Or Transloaded (Note: Sum must equal 100.)

Mineral(s)/Mineral product(s)	%
Sandstone	100
	Sum: 100

## Proposed Activity To Be Conducted

Type(s) of activity presently conducted at applicant's existing facility or proposed to be conducted at facility (Select Yes or No):

Activity	Apply?
Adjacent/associated asphalt/concrete plant(s)	No
Alternative fuels operation	No
Auger mining	No
Cement production	No
Chemical processing or leaching	No
Chemicals used in process or wastewater treatment (coagulant, biocide, etc.)	No
Construction related temporary borrow pits/areas	No
Creek/stream crossings	No
Dredging	No
Excavation	Yes
Grading, clearing, grubbing, etc.	Yes
Hydraulic mining	No
Hydraulic mining, dredging, instream or between stream-bank mining	No
Lime production	No
Low volume sewage treatment package plant	No
Mineral dry processing (crushing & screening)	No
Mineral loading	Yes
Mineral storing	Yes
Mineral transportation	Yes
Mineral wet preparation	No
Onsite construction debris or equipment storage/disposal	Yes
Onsite mining debris or equipment storage/disposal	Yes
Other beneficiation & manufacturing operations	No
Pre-construction ponded water removal	No
Pre-mining logging or land clearing	Yes
Preparation plant waste recovery	No
Quarrying	Yes
Reclamation of disturbed areas	Yes
Solution mining	No
Surface mining	Yes
Synthetic fuel production	No
Underground mining	No
Waterbody relocation or other alteration	No
Within-bank mining	Yes

**If the operation will include activities other than those listed above, please describe them below:**

N/A

**If the type of activity presently conducted or proposed is Mineral Transportation, please indicate which of the following apply:**

Barge	Apply?
Barge	No
Rail	No
Truck	Yes

## **Fuel - Chemical Handling, Storage, & Spill Prevention Control & Countermeasures (SPCC) Plan**

**Will fuels, chemicals, compounds, or liquid waste be used or stored onsite?**

Yes

Please identify the fuel, chemicals, compounds, or liquid waste and indicate the volume of each:

Volume (gallons)	Contents
2,000.0	Diesel Fuel
50.0	Hydraulic Oil
20.0	Motor Oil

### SPCC Plan

[ADEM- SPCC PLAN - TSLLC.pdf - 11/13/2024 12:38 PM](#)

#### Comment

NONE PROVIDED

## ASMC Regulated Entities

Is this a coal mining operation regulated by ASMC?

No

## Topographic Map Submittal

### Topographic Map

Attach to this application a 7.5 minute series U.S.G.S. topographic map(s) or equivalent map(s) no larger than, or folded to a size of 8.5 by 11 inches (several pages may be necessary), of the area extending to at least one mile beyond property boundaries. The topographic or equivalent map(s) must include a caption indicating the name of the topographic map, name of the applicant, facility name, county, and township, range, & section(s) where the facility are located. Unless approved in advance by the Department, the topographic or equivalent map(s), at a minimum, must show: a) An accurate outline of the area to be covered by the permit (b) An outline of the facility (c) All existing and proposed disturbed areas (d) Location of intake and discharge areas (e) Proposed and existing discharge points (f) Perennial, intermittent, and ephemeral streams (g) Lakes, springs, water wells, wetlands (h) All known facility dirt/improved access/haul roads (i) All surrounding unimproved/improved roads (j) High-tension power lines and railroad tracks (k) Contour lines, township-range-section lines (l) Drainage patterns, swales, washes (m) All drainage conveyance/treatment structures (ditches, berms, etc.) (n) Any other pertinent or significant feature.

### Topographic Map

[RMQ-ADEM-2000.pdf - 02/22/2026 12:50 PM](#)

#### Comment

NONE PROVIDED

## Detailed Facility Map Submittal

### Detailed Facility Map

[RMQ-ADEM-500.pdf - 02/22/2026 12:51 PM](#)

#### Comment

NONE PROVIDED

## Outfalls (1 of 1)

Outfall Identifier: 001

### Feature Type

Outfall (External)

### Outfall Identifier

001

### Outfall Status

Proposed

Please be aware that you should only mark an outfall status as existing if (1) the Department has been previously notified that it was constructed as proposed or (2) it began discharge prior to this application. A proposed outfall is one that is being newly added to the permit OR one that has never discharged or has never been authorized by the Department to discharge. Should you have any questions about which status to select, please contact the Department's permit engineer for this site.

**Permit Action**

Move

**Receiving Water**

Calvert Prong Little Warrior River

**Check below if the discharge enters the receiving water via an unnamed tributary.**

Unnamed Tributary

**Location of Outfall**

34.01230500000001, -86.44776400000001

**New/Corrected Lat/Long Coordinates**

34.012266N LATITUDE, -086.447686 W LONGITUDE

**Distance to Receiving Water (ft)**

0.00

**Disturbed Area (acres)**

29.25

**Drainage Area (acres)**

43.04

**303(d) Segment?**

No

**TMDL Segment?**

No

---

Please do not add a new outfall unless you are requesting a modification that includes a new outfall. All of the currently permitted outfalls are already included in this form. If you add an outfall in error, please choose **Delete** under **Permit Action** for the outfall. If you have any questions, please contact your permit engineer BEFORE proceeding.

**Discharge Characterization**

**EPA Form 2C, EPA Form 2D, and/or ADEM Form 567 Submittal**

Yes, pursuant to 40 CFR 122.21, the applicant requests a waiver for completion of EPA Form 2C, EPA Form 2D, and ADEM Form 567 and certifies that the operating facility will discharge treated stormwater only; that chemical/compound additives are not used (unless waived in writing by the Department on a programmatic, categorical, or individual compound/chemical basis); that there are no process, manufacturing, or other industrial operations or wastewaters, including but not limited to lime or cement production and syngas operations; and that coal and coal products are not mined nor stored onsite.

Please download the following Excel file to enter your information. Once complete, please attach to the below control.

[Download spreadsheet here.](#)

**Required attachment:**

DISCHARGE CHARACTERIZATION1.pdf - 11/12/2024 03:13 PM

**Comment**

NONE PROVIDED

Please download the following Excel file to enter your information. Once complete, please attach to the below control.

[Download spreadsheet here.](#)

**Required attachment:**

DISCHARGE CHARACTERIZATION2.pdf - 11/12/2024 03:17 PM

**Comment**

NONE PROVIDED

## Discharge Structure Description & Pollutant Source

Please download the following Excel file to enter your information. Once complete, please attach to the below control.  
[Download spreadsheet here.](#)

### Required attachment:

DISCHARGE STRUCTURES.pdf - 11/12/2024 03:17 PM

### Comment

NONE PROVIDED

## Variance Request

Do you intend to request or renew one or more of the CWA technology variances authorized at 40 CFR 122.21(m)?

No

## Pollution Abatement & Prevention (PAP) Plan Summary (1 of 1)

### Outfall(s):

001P

Outfall Questions:	Please select one:
Runoff from all areas of disturbance is controlled	Yes
Drainage from pit area, stockpiles, and spoil areas directed to a sedimentation pond	Yes
Sedimentation basin at least 0.25 acre/feet for every acre of disturbed drainage	Yes
Sedimentation basin cleaned out when sediment accumulation is 60% of design capacity	Yes
Trees, boulders, and other obstructions removed from pond during initial construction	Yes
Width of top of dam greater than 12'	Yes
Side slopes of dam no steeper than 3:1	Yes
Cutoff trench at least 8' wide	Yes
Side slopes of cutoff trench no less than 1:1	Yes
Cutoff trench located along the centerline of the dam	Yes
Cutoff trench extends at least 2' into bedrock or impervious soil	Yes
Cutoff trench filled with impervious material	Yes
Embankments and cutoff trench 95% compaction standard proctor ASTM	Yes
Embankment free of roots, tree debris, stones >6" diameter, etc.	Yes
Embankment constructed in lifts no greater than 12"	Yes
Spillpipe sized to carry peak flow from a one year storm event	N/A
Spillpipe will not chemically react with effluent	N/A
Subsurface withdrawal	Yes
Anti-seep collars extend radially at least 2' from each joint in spillpipe	N/A
Splashpad at the end of the spillpipe	Yes
Emergency Spillway sized for peak flow from 25-yr 24-hr event if discharge not into PWS classified stream	Yes
Emergency spillway sized for peak flow from 50-yr 24-hr event if discharge is into PWS classified stream	Yes
Emergency overflow at least 20' long	Yes
Side slopes of emergency spillway no steeper than 2:1	Yes
Emergency spillway lined with riprap or concrete	Yes
Minimum of 1.5' of freeboard between normal overflow and emergency overflow	Yes
Minimum of 1.5' of freeboard between max. design flow of emergency spillway and top of dam	Yes
All emergency overflows are sized to handle entire drainage area for ponds in series	N/A

Outfall Questions:	Please select one:
Dam stabilized with permanent vegetation	Yes
Sustained grade of haul road <10%	Yes
Maximum grade of haul road <15% for no more than 300'	Yes
Outer slopes of haul road no steeper than 2:1	Yes
Outer slopes of haul road vegetated or otherwise stabilized	Yes
Detail drawings supplied for all stream crossings	N/A
Short-Term Stabilization/Grading And Temporary Vegetative Cover Plans	Yes
Long-Term Stabilization/Grading And Permanent Reclamation or Water Quality Remediation Plans	Yes

**Identify and provide detailed explanation for any  N  or  N/A  response(s):**

Basin 001P to Discharge via Stone Lined Spillway  
 No Spillpipe Proposed, Emergency Spillway and Normal Discharge from Stone Lined Spillway.  
 No Basins in series are proposed.  
 No Stream Crossing are proposed.

**Pollution Abatement & Prevention (PAP) Plan Review Checklist**

General Information:	Please select one:
PE Seal with License #	Yes
Name and Address of Operator	Yes
Legal Description of Facility	Yes
Name of Company	Yes
Number of Employees	Yes
Products to be Mined	Yes
Hours of Operation	Yes
Water Supply and Disposition	Yes

Maps:	Please select one:
Topographic Map including Information from Part XIII (a) <input type="checkbox"/> (o) of this Application	Yes
1 <input type="checkbox"/> 500 <input type="checkbox"/> or Equivalent Facility Map including Information from Part XIV of this Application	Yes

Detailed Design Diagrams:	Please select one:
Plan Views	Yes
Cross-section Views	Yes
Method of Diverting Runoff to Treatment Basins	Yes
Line Drawing of Water Flow through Facility with Water Balance or Pictorial Description of Water Flow	Yes

**CORRECTION REQUEST (CORRECTED)**

**Basin 001 Volume**

ADEM regulations require the volume of sedimentation basins to be equal to or greater than 0.25 ac-ft per acre of disturbed land. The disturbed area associated with Basin 001 is 36 acres, therefore the volume of Basin 001 should be able to contain 9 ac-ft. The basin's current storage capacity is 4.56 ac-ft  
 Created on 8/28/2025 8:09 AM by **Skylar Wilson**

**1 COMMENT**

**Jerry Williams (jerryw@taskemi.com) (2/22/2026 12:37 PM)**

PAP PLAN UPDATED AND BASIN 001 AND DRAINAGE AREAS HAVE BEEN RESIZED 02-22-26.

**CORRECTION REQUEST (CORRECTED)**

**Sediment Basin Embankment Slope**

The front and back slope for the embankment should not be steeper than 3:1, but the design detail page has the front and back slope labelled as 2.5:1 for the embankment  
 Created on 7/7/2025 8:57 AM by **Skylar Wilson**

1 COMMENT

Jerry Williams (jerryw@taskemi.com) (2/22/2026 12:39 PM)

BASIN 001 EMBANKMENT SLOPES UPDATED IN PAP PLAN TO REFLECT 3:1 SLOPES 2-22-26.

<b>Narrative of Operations:</b>	<b>Please select one:</b>
Raw Materials Defined	Yes
Processes Defined	Yes
Products Defined	Yes

<b>Schematic Diagram:</b>	<b>Please select one:</b>
Points of Waste Origin	Yes
Collection System	Yes
Disposal System	Yes

<b>Post Treatment Quantity and Quality of Effluent:</b>	<b>Please select one:</b>
Flow	Yes
Suspended Solids	Yes
Iron Concentration	Yes
pH	Yes

<b>Description of Waste Treatment Facility:</b>	<b>Please select one:</b>
Pre-Treatment Measures	Yes
Recovery System	Yes
Expected Life of Treatment Basin	Yes
Measures for Ensuring Access to All Treatment Structures and Related Appurtenances including Outfall Locations	Yes
Schedule of Cleaning and/or Abandonment	Yes

<b>Other:</b>	<b>Please select one:</b>
Precipitation/Volume Calculations/Diagram Attached	Yes
BMP Plan for Haul Roads	Yes
Measures for Minimizing Impacts to Adjacent Stream (e.g., Buffer Strips, Berms)	Yes
Measures for Ensuring Appropriate Setbacks are Maintained at All Times	Yes
Methods for Minimizing Nonpoint Source Discharges	Yes
If Chemical Treatment Used, Methods for Ensuring Appropriate Dosage	Yes
Facility Closure Plans	Yes
PE Rationale(s) For Alternate Standards, Designs or Plans	N/A

Identify and provide detailed explanation for any **◆N◆** or **◆N/A◆** response(s):

No Alternative Standards, Designs or Plans proposed.

## **Pollution Abatement & Prevention (PAP) Plan**

Is this a coal mining operation regulated by ASMC?

No

**PAP Plan (non-coal mining facilities)**

[ADEM-PAP PLAN UPDATE 02-2026.pdf - 02/22/2026 02:44 PM](#)

**Comment**

NONE PROVIDED

## **Professional Engineer (PE)**

### **Registration License Number**

AI 12739

### **Professional Engineer**

**Prefix**

Mr.

**First Name      Last Name**

Jerry              Williams

**Title**

Professional Engineer

**Organization Name**

TASK Engineering Management Inc.

**Phone Type      Number              Extension**

Business              2059785070

**Email**

jerryw@taskemi.com

**Address**

2832 MONTE DESTE DR  
VESTAVIA HLS, AL 35216

## **Information for the Applicant**

### **Please read the following information and acknowledge below:**

Contact the Department prior to submittal with any questions or to request acceptable alternate content/format.

Be advised that you are not authorized to commence regulated activity until this application can be processed, publicly noticed, and approval to proceed is received in writing from the Department.

EPA Form(s) 1 and 2F need not be submitted unless specifically required by the Department. EPA Form(s) 2C and/or 2D are required to be submitted unless the applicant is eligible for a waiver and the Department grants a waiver, or unless the relevant information required by EPA Form(s) 2C and/or 2D are submitted to the Department in an alternative format acceptable to the Department.

Planned/proposed mining sites that are greater than 5 acres, that mine/process coal or metallic mineral/ore, or that have wet or chemical processing, must apply for and obtain coverage under an Individual or General NPDES Permit prior to commencement of any land disturbance. Such Individual NPDES Permit coverage may be requested via this ADEM Form 315.

The applicant is advised to contact:

- (1) The Alabama Surface Mining Commission (ASMC) if coal, coal fines, coal refuse, or other coal related materials are mined, transloaded, processed, etc.;
- (2) The Alabama Department of Labor (ADOL) if conducting non-coal mining operations;
- (3) The Alabama Historical Commission for requirements related to any potential historic or culturally significant sites;
- (4) The Alabama Department of Conservation and Natural Resources (ADCNR) for requirements related to potential presence of threatened/endangered species;
- (5) The US Army Corps of Engineers, Mobile or Nashville Districts, if this project could cause fill to be placed in federal waters or could interfere with navigation.

The Department must be in receipt of a completed version of this form, including any supporting documentation, and the appropriate processing fee [including Greenfield Fee and Biomonitoring & Toxicity Limits fee(s), if applicable], prior to development of a draft NPDES permit.

### **Acknowledgement**

I acknowledge I have read and understand the information above.

## **Additional Attachments**



**Additional Attachments***NONE PROVIDED***Comment***NONE PROVIDED***Application Preparer****Application Preparer****Prefix**

Mr.

**First Name      Last Name**

Jerry                  Williams

**Title**

Professional Engineer

**Organization Name**

TASK Engineering Management Inc.

**Phone Type    Number          Extension**

Business          2059785070

**Email**

jerryw@taskemi.com

**Address**2832 MONTE DESTE DR  
VESTAVIA HLS, AL 35216**Fees Assessed**

The following itemized fees have been assessed in accordance with Fee Schedule D and 335-1-6-.04(a) of ADEM Admin. Code Division 1 regulations based on the information provided in this application.

If the correct fees are not displayed, please contact your permit engineer PRIOR to submitting the form. Do NOT answer questions erroneously in order to have the correct fee assessed.

**Mineral/Resource Extraction Mining, Storage Transloading, Dry Processing:**

5820

**Fee****Fee**

5820

**Revisions**

Revision	Revision Date	Revision By
Revision 1	11/9/2024 2:02 PM	Jerry Williams
Revision 2	6/12/2025 4:44 PM	Jerry Williams
Revision 3	9/3/2025 11:31 AM	Jerry Williams

# Agreements and Signature(s)

## SUBMISSION AGREEMENTS

- I am the owner of the account used to perform the electronic submission and signature.
- I have the authority to submit the data on behalf of the facility I am representing.
- I agree that providing the account credentials to sign the submission document constitutes an electronic signature equivalent to my written signature.
- I have reviewed the electronic form being submitted in its entirety, and agree to the validity and accuracy of the information contained within it to the best of my knowledge.

## Professional Engineer (PE)

A detailed, comprehensive Pollution Abatement & Prevention (PAP) Plan must be prepared, signed, and certified by a professional engineer (PE), registered in the State of Alabama, and the PE must certify as follows: I certify under penalty of law that the technical information and data contained in this application, and a comprehensive Pollution Abatement & Prevention (PAP) Plan, including any attached SPCC plan, maps, engineering designs, etc. acceptable to ADEM, for the prevention and minimization of all sources of pollution in stormwater and authorized related process wastewater runoff has been prepared under my supervision for this facility utilizing effective, good engineering and pollution control practices and in accordance with the provisions of this Permit, and ADEM Admin. Code Division 335-6, including Chapter 335-6-9 and Appendices A & B. If the PAP Plan is properly implemented and maintained by the Permittee, discharges of pollutants can reasonably be expected to be effectively minimized to the maximum extent practicable and according to permit discharge limitations and other permit requirements. The applicant has been advised that appropriate pollution abatement/prevention facilities and structural & nonstructural management practices or Department approved equivalent management practices as detailed in the PAP Plan must be fully implemented and regularly maintained as needed at the facility in accordance with good sediment, erosion, and other pollution control practices, permit requirements, and other ADEM requirements to ensure protection of groundwater and surface water quality.

**Signed By** Jerry Williams on 02/26/2026 at 3:24 PM

## Responsible Official

This application must be signed and initialed by a Responsible Official of the applicant pursuant to ADEM Admin. Code Rule 335-6-6-.09 who has overall responsibility for the operation of the facility. I certify under penalty of law that this document, including technical information and data, the PAP Plan, including any SPCC plan, maps, engineering designs, and all other attachments were prepared under my direction or supervision in accordance with a system designed to assure that qualified personnel properly gathered and evaluated the information submitted. Based on my inquiry of the PE and other person or persons under my supervision who manage the system or those persons directly responsible for gathering the information, the information submitted is, to the best of my knowledge and belief, true, accurate, and complete. I am aware that there are significant penalties for submitting false information including the possibility of fine or imprisonment for knowing violations. A comprehensive PAP Plan to prevent and minimize discharges of pollution to the maximum extent practicable has been prepared at my direction by a PE for this facility utilizing effective, good engineering and pollution control practices and in accordance with the provisions of ADEM Admin. Code Division 335-6, including Chapter 335-6-9 and Appendices A & B, and information contained in this application, including any attachments. I understand that regular inspections must be performed by, or under the direct supervision of, a PE and all appropriate pollution abatement/prevention facilities and structural & nonstructural management practices or Department approved equivalent management practices identified by the PE must be fully implemented prior to and concurrent with commencement of regulated activities and regularly maintained as needed at the facility in accordance with good sediment, erosion, and other pollution control practices and ADEM requirements. I understand that the PAP Plan must be fully implemented and regularly maintained so that discharges of pollutants can reasonably be expected to be effectively minimized to the maximum extent practicable and according to permit discharge limitations and other requirements to ensure protection of groundwater and surface water quality. I understand that failure to fully implement and regularly maintain required management practices for the protection of groundwater and surface water quality may subject the Permittee to appropriate enforcement action. I certify that this form has not been altered, and if copied or reproduced, is consistent in format and identical in content to the ADEM approved form. I further certify that the discharges described in this application have been tested or evaluated for the presence of non-stormwater discharges and any non-mining associated beneficiation/process pollutants and wastewaters have been fully identified. I acknowledge my understanding that I may be required to obtain a permit from the ADOL. I acknowledge my understanding that if the proposed activities will be conducted in or potentially impact waters of the state or waters of the US (including wetlands), that I may be required to obtain a permit from the USACE.

**Signed By** Eduardo Mejia on 02/26/2026 at 1:25 PM







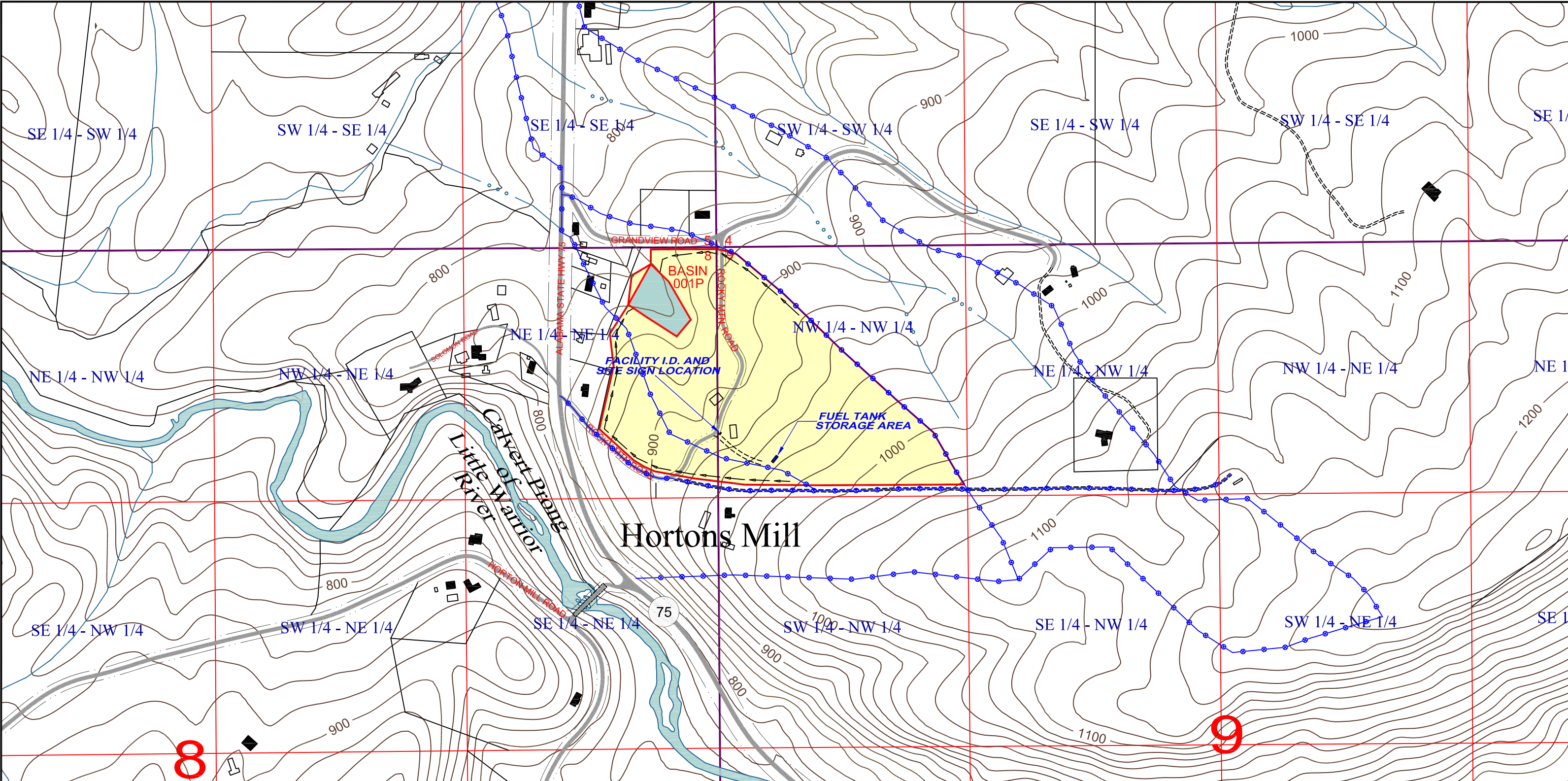





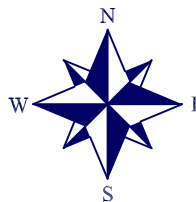







**TREMENDOUS STONE, LLC  
ROCKY MOUNTAIN QUARRY**

GENERAL PLAN VIEW MAP  
SCALE: 1" = 500'  
CONTOUR INTERVAL: 20 FT.



**MAP LEGEND**

-  PERMIT AREA
-  PUBLIC ROAD
-  STATE HIGHWAY SYSTEM
-  ROAD ROW
-  ROAD SETBACK
-  PRIVATE ROAD
-  INTERMITTENT DRAINAGE COURSE
-  DRAINAGE DIVIDE
-  DIVERSION DITCH
-  BASIN 001
-  SEDIMENT BASIN/OUTFALL

**TASK EMI**  
CONSULTING ENGINEERS  
2832 MONTE DESTO DRIVE  
BIRMINGHAM, ALABAMA 35216  
(205)978-5070  
email: jerryw@taskemi.com

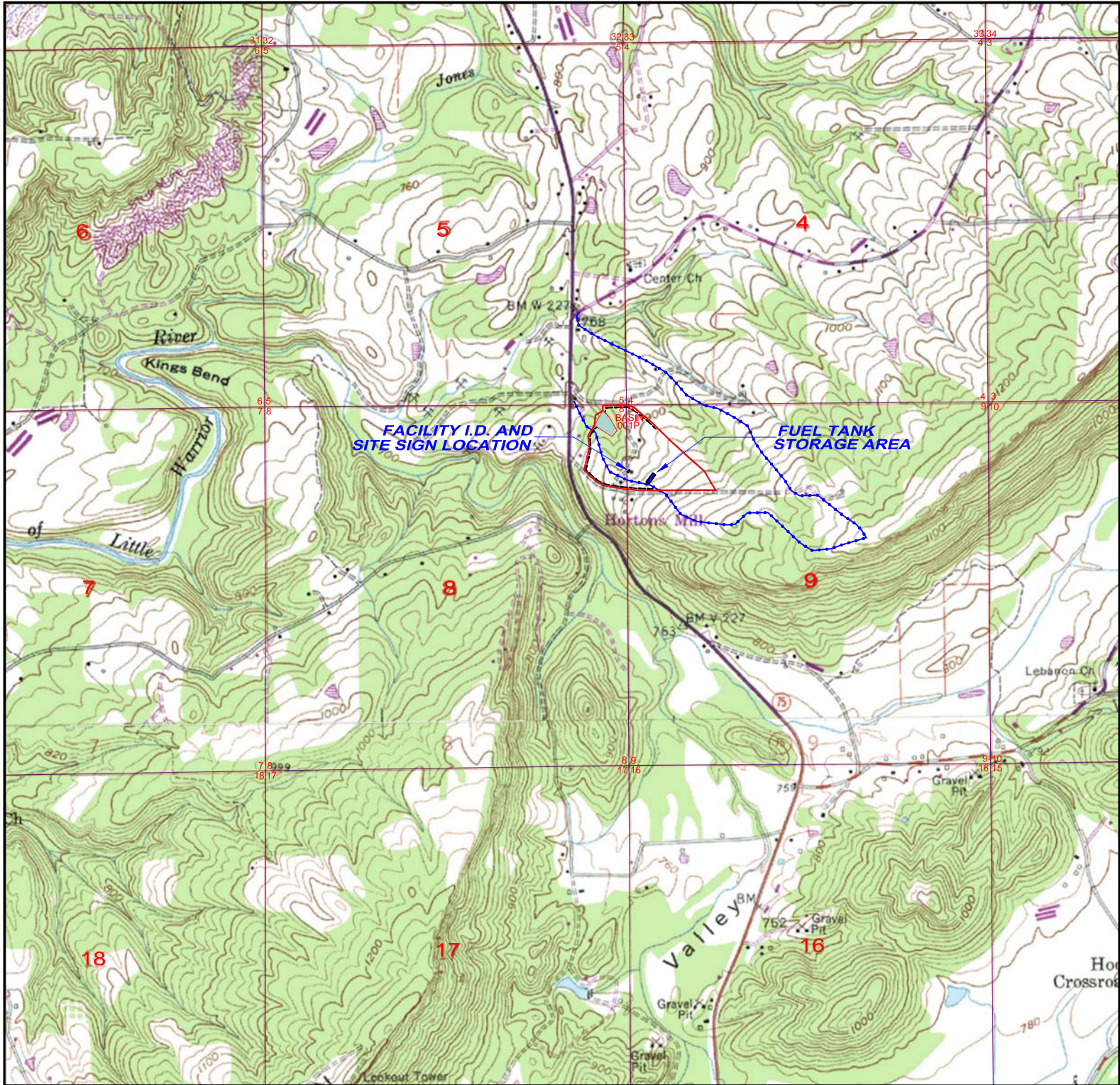

**NPDES PERMIT MAP**  
**SECTION 9**  
**TOWNSHIP 12 SOUTH, RANGE 2 EAST,**  
**BLOUNT COUNTY, ALABAMA**  
**SCALE 1"= 2000'**

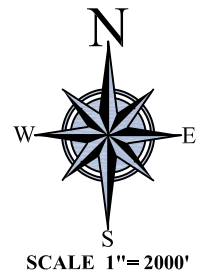

BASE MAP: CLARENCE USGS QUAD.

 PERMIT BOUNDARY  
 SEDIMENT BASIN / OUTFALL

SHEET	SCALE
<b>1 OF 1</b>	<b>1" = 2000'</b>

CLIENT / MINE
<b>TREMENDOUS STONE, LLC</b> <b>ROCKY MOUNTAIN QUARRY</b>

 <b>TASK EMI</b> CONSULTING ENGINEERS 2832 Monte Deste Drive BIRMINGHAM, ALABAMA 35216 (205) 978-5070
---

# **SPILL PREVENTION CONTROL AND COUNTERMEASURES PLAN**

Prepared for:

Alabama Department of Environmental Management

TREMENDOUS STONE, LLC

ROCKY MOUNTAIN QUARRY

NPDES AL0083950

Permit Renewal

Prepared By:

TASK Engineering Management Inc.  
2832 Monte Deste Drive  
Birmingham, Alabama 35216  
205-978-5070  
Email: [jerryw@taskemi.com](mailto:jerryw@taskemi.com)



## Spill Prevention Control and Countermeasure Plan

**Tremendous Stone, LLC  
Rocky Mountain Quarry  
Section 9, T12S, R2E  
Blount County, Alabama  
Clarence U.S.G.S. Quadrangle**

### Facility Telephone Number:

Office Phone Number                    205-274-5363  
E-mail:                                        tremendousstone@gmail.com

### Facility Contact and Address:

Eduardo Mejia, Owner,  
Tremendous Stone, LLC  
33750 Highway 75  
Oneonta, Alabama 35121

1. This facility has never experienced a spill from any fuel or other chemical storage tanks.
2. The containment structures will be located in an area that is not subject to periodic flooding at this highest elevation available.
3. This plan provides for the containment of the following:

<u>No. Of Tanks</u>	<u>Total Capacity</u>	<u>Material</u>
1	2,000 Gal	Diesel Fuel
3	100 Gal	Hydraulic Oil (Double Wall)
6	20 Gal	Motor Oil (Gallon Containers)

The area around the tanks is enclosed by a dike which exceeds the volume capacity of the largest tank in the bermed area by 10%.

4. The nearest surface water of the State is UT of Calvert Prong.
5. The dikes are constructed of impervious material around the tank area. There is a 2” minimum pipe with a manual gate valve, which allows rainwater discharge when it is required. The valve is to remain closed at all times and is to be locked until the diked area collects enough rainwater to require draining. After an inspection of the water to determine that no pollutants are present, the valve will be opened to allow the proper drainage, and then will be immediately closed and re-locked. The containment system is located such that rainwater released through normal de-watering drains to a permitted treatment structure (Sediment Basin 001P).

If pollutants (oil) are present in the rainwater, the pollutants will be removed from the water prior to drainage operations. Pollutants will be disposed of in accordance with existing State and Federal regulations. In addition, a log will be maintained which indicates the date when the containment structure was de-watered, the person conducting the de-watering, and a brief description of the water (i.e., oily sheen, clear, slightly turbid, oily smell, etc.).

6. If a spill should occur, the usable fuel oil within the diked area shall immediately be pumped into tanker trucks for transporting to another storage tank. Oil absorbent material will be kept available to contain any spills. The usable fuel oil and the contaminated soil in the area will be excavated and disposed of in accordance with existing State and Federal Regulations.
7. A written record shall be maintained by the General Mine Superintendent of any spill which occurs, and the actions taken to properly dispose of all spilled material and the cleanup procedures.
8. All unloading of transport vehicles to fill the tanks will meet minimum requirements and regulations established by the Department of Transportation. The tanks will be attended while filling to prevent overflow, and to note visible leaks from seams, gaskets, valves, etc. The General Superintendent of the facility will make periodic inspections of the unloading area to detect signs of minor spills. If spills are evident the contaminated soil will be disposed of in accordance with existing State and Federal regulations. If the spills continue, a paved unloading ramp equipped with an oil-water separator will be constructed.
9. All personnel who are in any way connected with unloading transport vehicles, use of fuel oil, maintenance of the facility, or responsible for storm water drainage and spill cleanup will be made familiar with this plan, and a copy of this plan will be posted and readily available to all personnel at the facility.

#### Potential Sources of Spills:

A) Tank Valve Rupture:

Prevention - Properly maintain tanks and keep them in good condition. visually inspect tanks periodically for leaks, and tank foundations for cracks and unusual settling.

B) Tank Overfill:

Prevention - Truck drivers should follow correct operating procedures when unloading diesel fuel and stay with equipment at all times during unloading operations. Key personnel should know that the truck is in the mine area unloading fuel.

C) Hose Rupture During Unloading and Spillage From Hoses After Disconnection:

Prevention - Periodic inspection of transport unloading hoses, the replacement of hoses as necessary, and use of the proper hose drainage procedure.

10. In The Event of An Oil Spill Call:

The National Response Center: 1-800-424-8802

The Alabama Emergency Management Agency: 1-800-843-0699

The Alabama Department of Environmental Management 1-334-271-7700

Report the Following Information:

- 1) Name, address, and telephone number of person reporting spill.
- 2) Exact location of facility and spill.
- 3) Company name and NPDES permit number.
- 4) Material spilled.
- 5) Estimated quantity.
- 6) Source of spill.
- 7) Cause of spill.
- 8) Nearest down-stream body of water to receive spill.
- 9) Discuss/advise regarding actions to take for containment and clean up.

11. The shop area and equipment area at the quarry site will be kept gated and locked to prevent vandalism or theft whenever management personnel of Tremendous Stone, LLC are not present.

All key personnel will be fully trained in all aspects of this plan, the proper use of personal protective gear, and all reporting and record keeping procedures. All non-key personnel will be made familiar with the plan and will be instructed on personal safety.

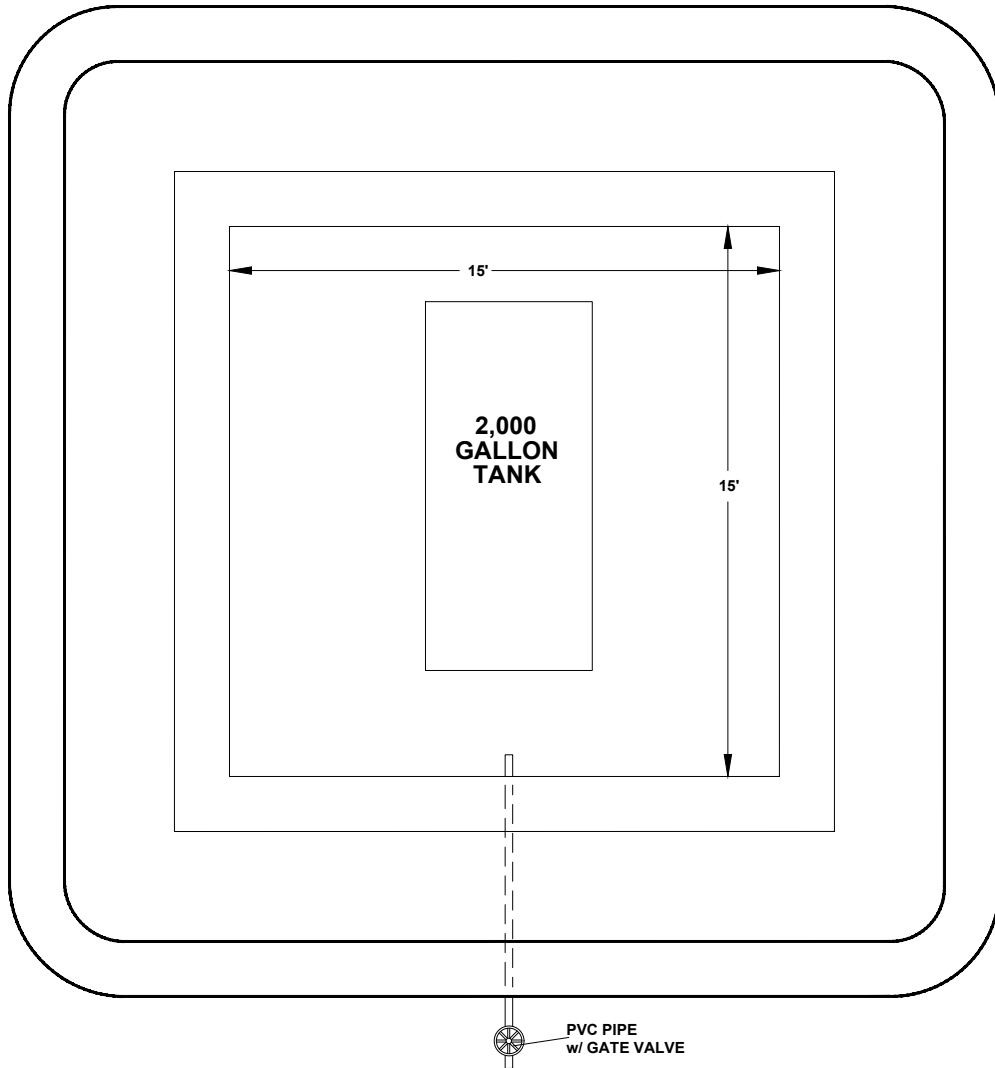

**PLAN VIEW**

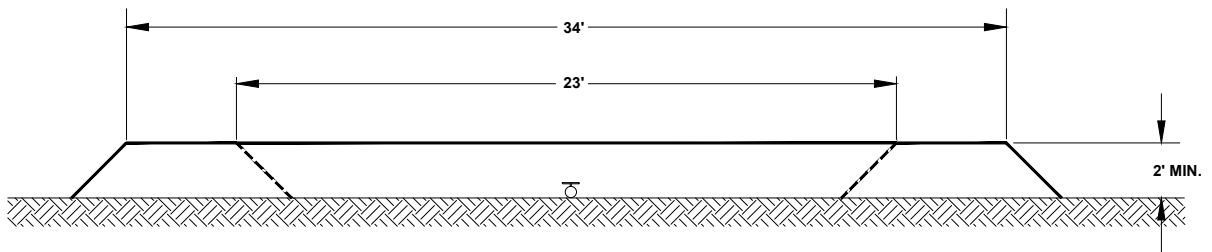

**ELEVATION VIEW**

<p>SHEET <b>1 OF 2</b></p>	<p>SCALE <b>NONE</b></p>	<p>TITLE <b>SPILL PREVENTION PLAN TYPICAL CONTAINMENT BERM DETAIL</b></p>	 <p><b>TASK EMI</b> CONSULTING ENGINEERS 2832 MONTE DESTRE DRIVE BIRMINGHAM, ALABAMA 35216 (205) 978-5070</p>
--------------------------------	------------------------------	---	--

BERM DESIGN  
TYPICAL SECTIONS

FRONT VIEW

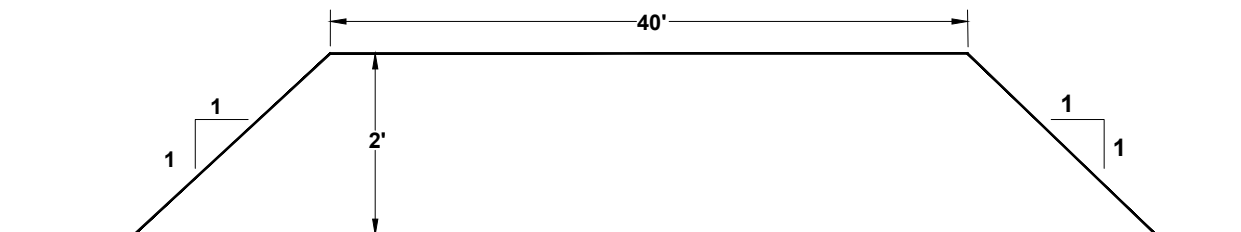

SIDE VIEW

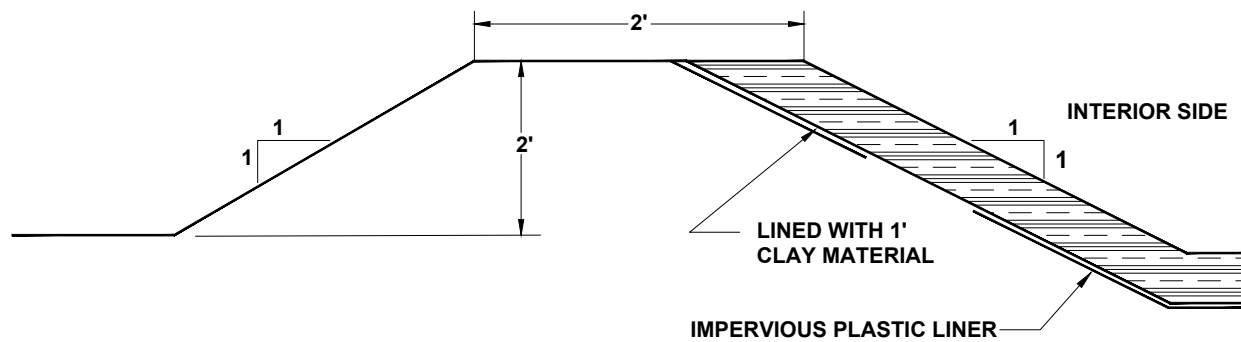

NOT TO SCALE

SHEET

2 OF 2

SCALE

NONE

TITLE

SPILL PREVENTION PLAN  
TYPICAL CONTAINMENT BERM SECTION

**TASK EMI**  
CONSULTING ENGINEERS  
2832 MONTE DESTO DRIVE  
BIRMINGHAM, ALABAMA 35216  
(205) 978-5070

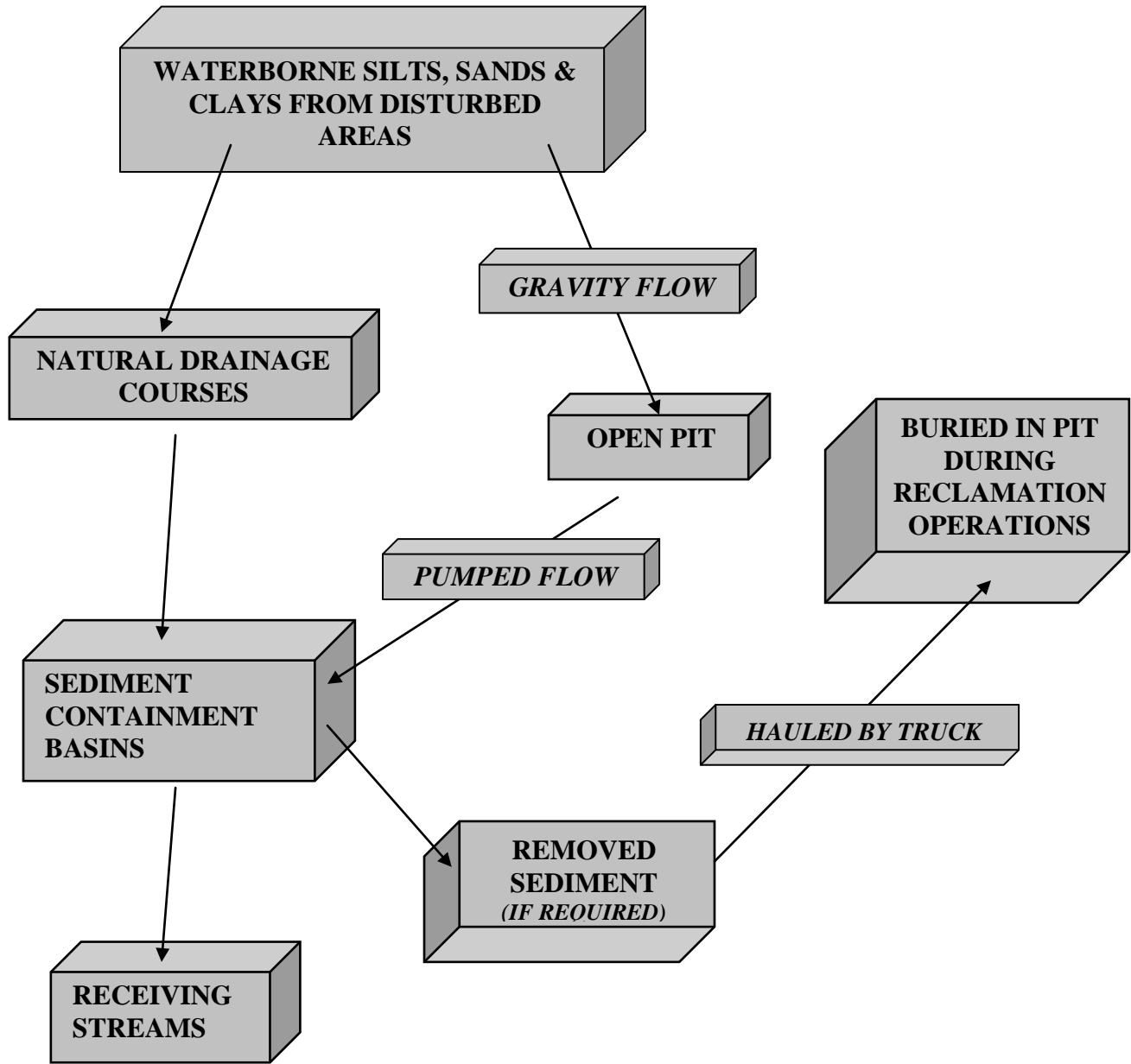

**SCHEMATIC DIAGRAM  
OF  
WASTE CYCLE**

## **POLLUTION ABATEMENT PLAN**

Prepared for:

Alabama Department of Environmental Management

TREMENDOUS STONE, LLC

ROCKY MOUNTAIN QUARRY

NPDES AL0083950

Permit Application

Prepared By:

TASK Engineering Management Inc.

2832 Monte Deste Drive

Birmingham, Alabama 35216

205-978-5070

Email: [jerryw@taskemi.com](mailto:jerryw@taskemi.com)

## **INTRODUCTION**

This document is an application for a renewal of NPDES Permit AL0083950. Tremendous Stone, LLC, Rocky Mountain Quarry is located in Section 9, Township 12 South, Range 2 East, Blount County, Alabama. This application has been prepared in accordance with the rules and regulations of the Alabama Department of Environmental Management (ADEM).

This “Pollution Abatement Plan” is presented in two (2) parts, which includes a narrative description of operations and how they will conform to the format as outlined by the ADEM Water Division – Water Quality and Control Program, rules and regulations and will present the location and design of pollution and water control facilities to be constructed and/or implemented at the site. The plans and drawings as presented in this plan have been derived from rules and regulations from ADEM and from other generally accepted design data sources primarily from the U.S. Department of Agriculture, Soil Conservation Service. Generally, the narrative will follow the outline of Chapter 335-6-9-.03, Surface Mining Rules from the ADEM Water Division – Water Quality Program – Administrative Code.

## **OPERATOR**

The operator of this facility is Tremendous Stone, LLC, a limited liability company, which has its home office as follows:

Tremendous Stone, LLC  
P.O. Box 1786  
Oneonta, Alabama 35121

The address of the physical office location is as follows:

Tremendous Stone, LLC  
33316 Highway 75  
Oneonta, Alabama 35121



## **GENERAL INFORMATION**

### **Narrative of Operation Plan Sequence**

This Operation Plan Sequence describes the timing of operations and the location of the mine pollution control facilities, access roads and the general mining area. Decorative building sandstone rock will be quarried from the site utilizing block mining techniques. The general sequence of operations will be to construct sediment control facilities, remove standing timber, clear and grub the ground of the site, remove overburden, extract the sandstone from intact strata utilizing block quarrying techniques, remove, size and classify the stone for markets. After all marketable stone has been removed, the disturbed area will be re-graded and re-vegetated. Sediment control facilities will be constructed for each subwatershed area prior to commencing operations within the said subwatershed. Mobile equipment units will be used to remove the unconsolidated overburden material immediately above the target sandstone deposits. Light explosive blasting will be utilized where required to loosen the quarry blocks. Upon removal of the sandstone products they will be segregated, sized and stockpiled until sold and shipped via trucks to the purchaser. As final re-grading of the site is accomplished, re-vegetation will be performed and the timing and selection of vegetation species will be based on required planting seasons. The majority of the final product from this site will be produced by sizing and segregation operations performed by hand with some specialty stone products produced by cutting with a wet saw.

Generally, the major items of equipment to be used in the quarrying, processing and reclamation processes are comprised of mobile equipment units; including dozers, hydraulic excavators, blasthole drills, rock trucks, rubber tire loaders, service trucks and various farm tractors and support equipment for reclamation operations and a wet cutting stone saw for specialty products. Ten (10) to twelve (12) employees will form the necessary work force and working hours will be from 6:00 AM to 5:00 PM Monday through Saturday.

## **SEQUENCE OF QUARRYING OPERATIONS**

- 1) Construction of Sediment Control Structures
- 2) Timber Removal
- 3) Clearing and Grubbing
- 4) Overburden Removal
- 5) Block Quarrying Operations
- 6) Site Grading Operation
- 7) Revegetation

Runoff from the disturbed area will be controlled by proposed Basin 001P. Water from this basin will then be discharged an UT's of Calvert Prong of Little Warrior River. As the quarry site is developed pumping will be required to remove groundwater and/or accumulation of water from precipitation events. Any pumping of water will be directed to Basin 001 either directly or by constructed diversion ditches. The required sediment basin will be constructed in accordance with the specifications and design plans as presented in the attached Appendix A – “Sediment Basin Design and Construction Specifications”.

## **TOPOGRAPHIC MAP**

Design plans submitted with this document provide an existing contour map as taken from the Clarence U.S.G.S, 7½ Minute, Quadrangle Map. The map submitted shows the location and the layout of the quarry facility, drainage patterns and proposed outfall. All surface drainage from the quarry site drains naturally to Sediment Basin 001 via diversion ditches.

## **SURFACE WATER DIVERSIONS**

The attached topographic maps show the contours of the site and general drainage patterns. All disturbed surface drainage will gravity drain through the said sediment basin. Any pumped water will be diverted directly into Sediment Basin 001 or a constructed diversion ditch flowing into the designated basin.

All required diversions will be constructed in accordance with the attached Appendix B - “Diversion Ditch Design and Construction Specifications”.

## **QUALITY AND CHARACTERISTICS OF WASTE PRODUCTS**

The only waste products anticipated to be produced at this quarry site will be siltation from the overburden removal, quarrying and reclamation operations. The siltation will be trapped and settle when passing through Sediment Basin 001. The designated sediment basin will be cleaned out as needed to provide adequate sediment retention volume for incoming materials. The parameters of pH, total iron and manganese should pose no problem and should remain in compliance with NPDES requirements.

## **SOLID OR LIQUID WASTE DISPOSAL PLAN**

Sediment basins will be cleaned out when their capacity reach sixty (60%) percent of their design capacity and will be cleaned out in an environmentally safe manner (loader, backhoe, etc.). Sediment removed from sediment basins will be disposed of in a mined out area of the quarry site. With the amount of marketable product being removed from the pit, volume requirements for waste disposal will not be a problem.

## **SEDIMENT CONTROL FOR HAULROADS AND INCIDENTALS**

Haulroads, existing or proposed for this operation, will be ditched and stabilized by planting a grass mixture suitable for seasonal conditions, fertilizing and mulching all cut, fill, and borrow areas to minimize erosion and enhance re-stabilization. In small areas where incidental drainage cannot be diverted through sediment basins, silt fences or rock filter dams will be constructed to control runoff. Silt fences will be constructed in accordance with the attached Appendix C - "Silt Fence Design and Construction Specifications" and rock filter dams will be constructed in accordance with the attached Appendix E - "Rock Filter Dam Construction Specifications".

## **LOCATION OF ADJACENT STREAMS**

Included in this NPDES application is a map (Scale: 1"=2000') showing the location of all adjacent streams and the receiving water of this operation.

## **NON-POINT SOURCE DISCHARGE CONTROL**

All disturbed areas will be developed in such a manner as to route all drainage through the sediment basin, all drainage from the Rocky Mountain Pit should convey all sediment (silts, sands, clay, etc.) into the approved point source outfall. See the attached "Sediment Basin Design Parameters" for Sediment Basin 001.

## **PUBLIC WATER SUPPLIES**

The receiving waters from the proposed quarry are an UT's to Calvert Prong of Little Warrior River. The receiving waters of Calvert Prong are not a public water supply.

**APPENDIX A**  
**SEDIMENT BASIN**  
**DESIGN AND CONSTRUCTION SPECIFICATIONS**

## **SEDIMENT BASIN CONSTRUCTION SPECIFICATIONS**

Sediment basins (temporary or permanent) will be designed and constructed using the following as minimum specifications:

### **1. EMBANKMENT REQUIREMENTS**

- A) The minimum width of the top of the embankment will under no circumstance be less than twelve (12) feet.
- B) The embankment will have a minimum front and back slope no steeper than 3 horizontal to 1 vertical.
- C) The foundation area of the embankment will be cleared and grubbed of all organic matter with no surface slope steeper than one (1) horizontal to one (1) vertical. The entire wet area as measured from the upstream toe of the embankment to the normal pool level will be cleared of trees and large bush.
- D) A core will be constructed in a cutoff trench along the centerline of the embankment. The cutoff trench will be at least eight (8') feet wide with the side slope steepness to be no greater the 1 horizontal to 1 vertical. The material placed in the cutoff trench will be compacted to ninety-five (95%) percent of the standard proctor density, as set forth in ASTM.
- E) The embankment construction material will be free of sod, roots, stumps, rocks, etc., which exceed six (6) inches in diameter. The embankment material will be placed in layers of twelve (12) inches or less and compacted to ninety-five (95%) percent of the standard proctor density as set forth ASTM.
- F) The embankment, foundation and abutments will be designed and constructed to be stable under normal construction and operating conditions with a minimum static safety factor of 1.5 and a minimum seismic safety factor of 1.2, at normal pool level with steady seepage saturation conditions.
- G) The actual constructed height of the embankment will be a minimum of five (5%) percent higher than the design height to allow for settling over the life of the embankment.
- H) All basins will have a minimum of 1.5 feet of freeboard between the normal overflow and the emergency spillway and a minimum of 1.5 feet of freeboard between the height of the maximum design flow and the top of the dam anticipated from a 25 year – 24 Hour precipitation event.
- I) For embankments constructed as point source discharges, the embankment will be constructed and abutments keyed into undisturbed, virgin ground if at all possible. In the event that this cannot be achieved, additional design and construction specifications will be submitted in the Detailed Design Plans.

- J) The embankment all areas disturbed in the construction of the embankment will be seeded with a mixture of perennial and annual grasses, fertilized and mulched to prevent erosion and ensure re-stabilization. Hay dams, silt fences, rock check dams, etc. will be installed, where deemed necessary, as additional erosion prevention methods.

## **2. DISCHARGE STRUCTURE REQUIREMENTS**

- A) The primary spillway will be designed to adequately carry the anticipated peak runoff from a 25 Year – 24 Hour precipitation event. The combination primary and secondary (emergency) spillway system will be designed to safely carry the anticipated peak runoff from a 25 Year – 24 Hour precipitation event. When sediment basins are proposed in the drainage course of a public water supply, the spillway system will be designed and constructed to adequately carry the runoff from a 50 Year – 24 Hour precipitation event. The emergency spillway in the control section will be at least 20 feet in length: the side slopes will be no steeper than 2:1, and the percent slope from the entrance to the exit section of the emergency spillway will be no greater than that stated in the design plans.
- B) Channel linings for single channel spillway systems, will be riprap or concrete.
- C) When consisting of pipe, the primary spillway will be installed according to Class "C" pipe installation for embankment bedding. Where exposed above ground along the backslope of the embankment, the pipe will have an anti-seep collar installed at each joint of the discharge pipe to radiate at least two (2') feet from the pipe in all directions.
- D) Sediment basins with a single spillway system such as a skimmer board will be a trapezoidal open channel constructed in consolidated, non-erodible material and lined with rip-rap, concrete, asphalt or durable rock.
- E) The primary spillway will be designed and constructed with device to eliminate floating solids from leaving the impoundment. This device will consist of a turned down elbow when using pipe, a turbidity barrier, or a skimmer system when using an open channel spillway.
- F) When necessary to prevent erosion of the embankment or discharge area, a splash pad of rip-rap, durable rock, sacrete, etc. will be installed at the discharge end of the primary spillway.
- G) The combined spillway systems, for sediment basins constructed in series, will be designed to adequately accommodate the entire drainage area.

### **3. INSPECTION, MAINTENANCE AND CERTIFICATION REQUIREMENTS**

- A) Inspections will be conducted regularly during construction of the sediment basin by a qualified registered engineer or other qualified person under the direction of a professional engineer. Upon completion of construction, the sediment basin will be certified, by a qualified Registered Professional Engineer, to the Regulatory Authority as being constructed in accordance with the approved Detailed Design Plans.
- B) Sediment basins will be inspected semi-monthly for erosion, instability, etc., with maintenance performed as necessary, until the removal of the structure or an NPDES Permit is no longer required at this site.
- C) Sediment basins will be examined quarterly for structural weakness, instability, erosion, slope failure or other hazardous conditions with maintenance performed as necessary.
- D) If during the above described periodic inspections, it is determined that there exists signs or structural weakness, instability, erosion, slope failure, improper functioning, or other hazardous conditions, these will be repaired immediately.
- E) Standard anticipated maintenance will include repairing rills and gullies, repairing slope failures, re-seeding areas of failed or scarce vegetation, cleaning out or removing debris obstructing pipes and/or spillways to allow proper functioning, etc. Conditions requiring maintenance discovered during described periodic inspections will be performed immediately. Hazardous conditions observed during inspections will be reported immediately to the Regulatory Authority for further consultation or instructions.
- F) Retained sediment will be removed from each sediment basin when the accumulated sediment reaches sixty (60%) percent of its design capacity.

### **4. BASIN REMOVAL REQUIREMENTS**

- A) Upon completion of quarrying operation, reclamation, re-stabilization and effluent standards being met, the operator will submit to ADEM a request in writing to abandon, remove, or permanently leave the sediment basin(s) and measures that will be taken to comply with applicable ADEM regulations.
- B) Once the operator has received approval from ADEM, each sediment basin not proposed as a permanent water impoundment will be dewatered in a controlled manner by either pumping or siphoning. Upon successful dewatering, a determination will be made as to the retained sediment level in the basin. After determining the retained sediment level, a channel will be cut into the embankment down to the retained sediment level on the side of the embankment deemed most suitable to reach natural ground without encountering prohibiting rock. The embankment material removed from this newly constructed channel will be spread and



compacted over the previous impoundment (wet area) area to prevent erosion and ensure re-stabilization. The newly constructed channel will be of adequate width (minimum thirty (30) feet) and sloped to a grade (approximately 1% to 3%) which will cause all surface drainage to travel across this area in sheet flow, minimizing the possibility of erosion. Also, where necessary, hay dams will be installed in strategic locations across the width of the channel to retain sediment and slow the water velocity to a favorable rate. Upon removal of the embankment section, all disturbed areas will be graded in such a manner to ensure slope stability, successful re-stabilization and to minimize erosion. All disturbed areas will be seeded with a mixture of annual and perennial grasses, fertilized and mulched. No slope, existing or created in the removal of the sediment basin, will be left on a grade that will slip or slough.

## **5. PERMANENT WATER IMPOUNDMENT REQUIREMENTS**

- A) All sediment basins being left as permanent water impoundments will have supplemental data submitted to the Regulatory Authority concerning water quality, water quantity, size, depth, configuration, postmining land use, etc.
- B) Final grading slopes of the entire permanent water impoundment area will not exceed a slope of two (2) Horizontal to one (1) Vertical to provide for safety and access for future water users.

## **6. SEDIMENT BASIN DESIGN PARAMETERS**

### **SEDIMENT BASIN 001P**

Drainage Area: 43.04 Acres  
Disturbed Area: 35.37 Acres  
Primary Spillway: 10' Wide Rip Rap Lined Spillway Channel  
Emergency Spillway: Same as Primary Spillway  
Sediment Volume: 7.31 Acre-Feet  
Detention Volume: 5.70 Acre-Feet  
Normal Pool Volume: 13.01 Acre-Feet

Sediment Basin 001P is a semi-incised basin formed by constructing an embankment adjacent to the west permit boundary line in the NE/NE of Section 09, Township 12 South, Range 2 East, Blount County, Alabama. The embankment is approximately 12 feet high as measured from the upstream toe to the top of the embankment and will be incised an additional 10 feet to provide initial basin capacity. The Primary Spillway (10' Wide Rock Filter Dam) for Basin 001 will be installed approximately 3 feet lower (Elevation 834') than the top of the embankment (Elevation 837'). Basin 001P collects drainage from the entire permitted area from a small surface area around the shop, equipment parking and staging area and pit office area as well as the existing surface disturbed mining areas.

Due to the small surface area, a rock filter dam will be immediately constructed to treat existing drainage as the rock quarry product is removed from the basin area. Due to the potential lag time for construction of the primary basin, the rock filter dam will be constructed and certified to ADEM and will function as an approved outfall until replaced with the permanent primary Basin 001. As rock is removed and the sediment and detention storage volumes are attained, the final basin will be constructed and certified to ADEM. (See attached drawings "Sediment Basin Cross-Section" for design parameters of Sediment Basin 001P and Figures RFD-1 and RFD-2 "Rock Filter Dam Construction Specifications".)

## EMBANKMENT CROSS SECTION

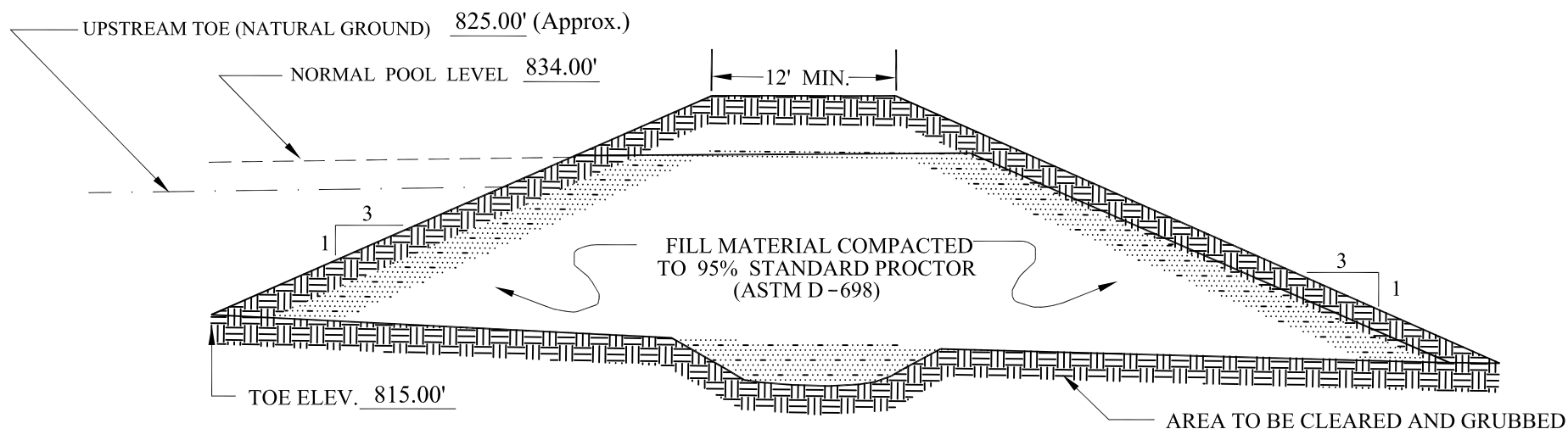

COMPANY: TREMENDOUS STONE, LLC

MINE NAME: ROCKY MOUNTAIN QUARRY

PERMIT #: NPDES AL0083950

BASIN I.D. #: SEDIMENT BASIN 001

## IMPOUNDMENT PROFILE

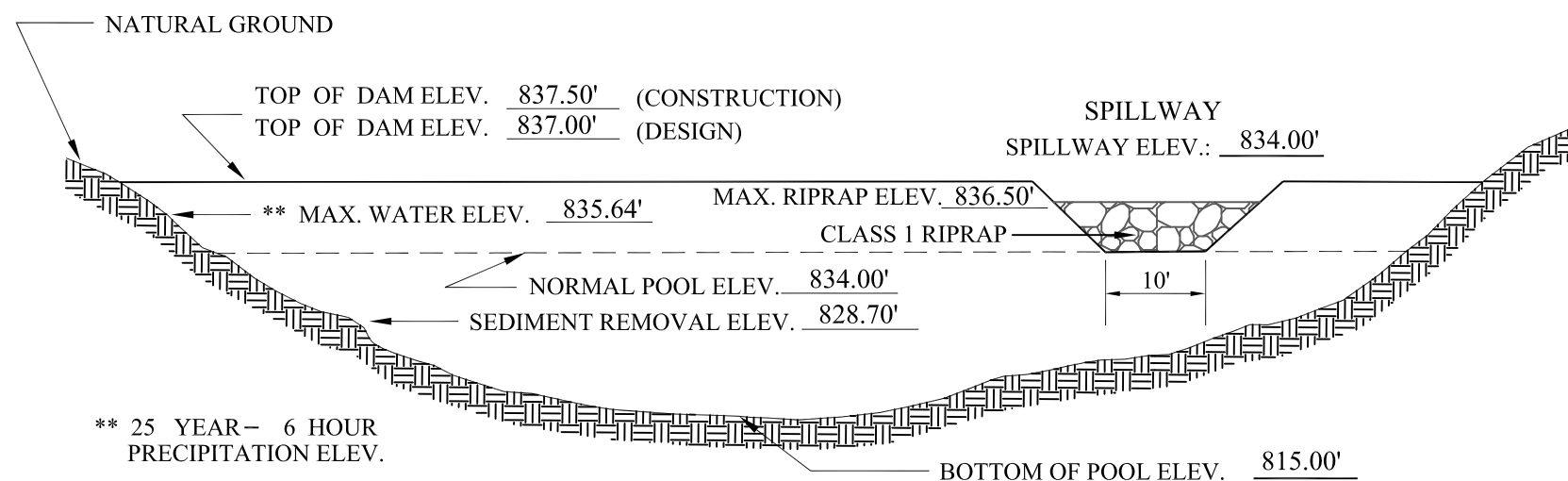

## KEY BASIN PARAMETERS

DRAINAGE AREA	<u>43.04</u> ACRES
PERMITTED AREA	<u>35.37</u> ACRES
DISTURBED AREA	<u>29.25</u> ACRES
SEDIMENT STORAGE	<u>7.31</u> AC.FT.
DETENTION STORAGE	<u>5.70</u> AC.FT.
PERMANENT POOL CAPACITY	<u>13.01</u> AC.FT.

## EMERGENCY SPILLWAY

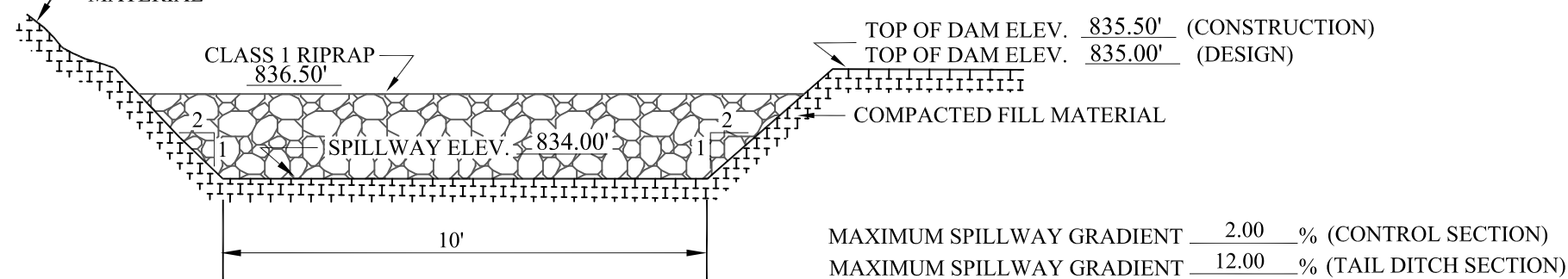

SEE TYPICAL SPILLWAY PROFILE SHEET, SPILLWAY CONTROL SECTION AND TAIL DITCH DESIGN FOR CHANNEL LINING REQUIREMENTS

**APPENDIX B**  
**DIVERSION DITCH**

## **DIVERSION DITCH AND DIVERSION BERM DESIGN AND CONSTRUCTION SPECIFICATIONS**

- 1) Temporary diversions will be designed and constructed to adequately carry the runoff from a 2 Year – 6 Hour precipitation event.
- 2) Permanent diversions will be designed and constructed to adequately carry the runoff from a 10 Year – 6 Hour precipitation event.
- 3) Permanent diversions will be designed and constructed with gently sloping banks stabilized with appropriate vegetation.
- 4) All diversions will be designed, constructed and maintained, using the best technology currently available, whereas additional contribution of suspended solids to stream-flow and to runoff outside the permit area is prevented.
- 5) Maintenance of appropriate gradient, channel lining, re-vegetation, roughness structures, detention basins, etc. will be used, when necessary, as sediment control measures for these diversions.
- 6) Diversions will not be constructed on existing landslides nor be located so as to increase the potential for landslides.
- 7) Temporary diversions will be removed and the affected area regraded, topsoiled (if required) and re-vegetated when no longer needed.
- 8) Channel linings, for diversions with slopes of five (5%) percent or less, will consist of a mixture of both annual and perennial grasses being predominantly fescue and Bermuda. Channel linings, for diversions with slopes greater than five (5%) percent, will consist of riprap or other non-erodible material or cut into non-erodible material.
- 9) Adequate freeboard will be provided for protection for transition of flows and critical areas such as swells and curves along the entire diversion length.
- 10) At discharge points, where diversions intersect with natural streams or exit velocities of the diversion flows are greater than that of the receiving stream, energy dissipaters will be installed when deemed necessary.
- 11) Excess material excavated in the construction of the diversion, not needed for diversion channel geometry or the re-grading of the channel; will be disposed of in the quarry area.
- 12) Diversion will not be designed or constructed to divert water into underground mines without written approval from the Regulatory Authority.

- 13) The entire area in which a diversion berm is proposed will be cleared and grubbed of all organic material, scarified, and no surface slopes will be left steeper than 1V:1H.
- 14) Diversion berms will be constructed with desirable material, free of sod, stones, roots, limbs, etc. over six (6") inches in diameter. This material will be spread in layers no greater than twelve (12") inches in thickness and compacted to ninety five (95%) percent of the standard proctor density, as outlined in ASTM, until the design height is reached.
- 15) Upon completion of construction of diversion ditches or diversion berms, all disturbed areas will be seeded with a mixture of both annual and perennial grasses, fertilized, and mulched in order to minimize erosion and ensure re-stabilization.
- 16) All diversions (berms and ditches) will be examined quarterly for erosion, instability, structural weakness, or other hazardous conditions and maintenance performed as necessary.

# DIVERSION DITCH TYPICAL CROSS-SECTION

GRADE: 1% MINIMUM  
3% MAXIMUM

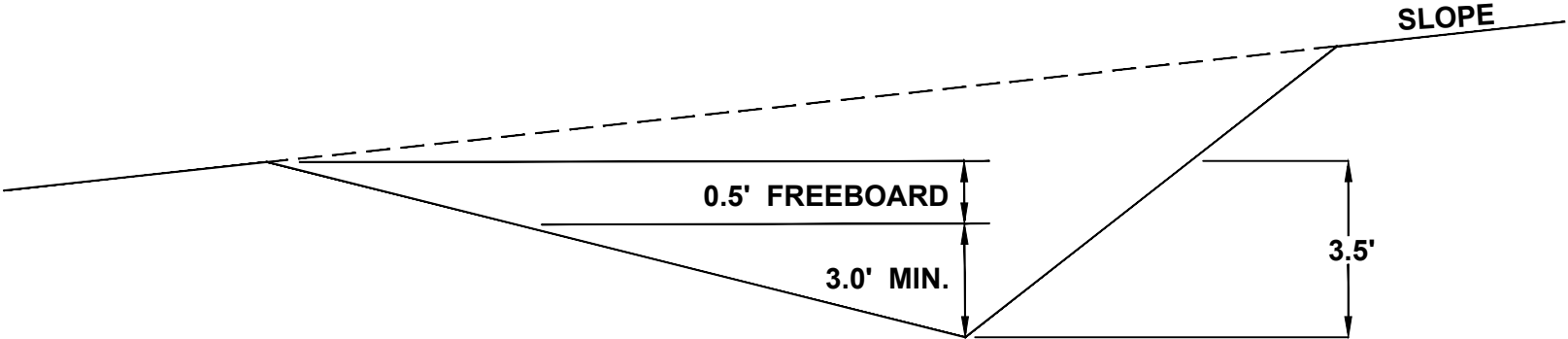

DITCH PROTECTIVE LINER: GRASS MIXTURE, PREDOMINATELY  
BERMUDA AND FESCUE GRASSES.

**APPENDIX C**  
**SILT FENCE**  
**DESIGN AND CONSTRUCTION SPECIFICATIONS**



## **SILT FENCE DESIGN AND CONSTRUCTION SPECIFICATIONS**

- 1) Mesh height – 3’0” including 6” trench flap.
- 2) Prefabricated with 4½’ long treated hardwood stakes spaced on 7’7” centers.
- 3) Mesh opening – Equivalent Opening Size (E.O.S.) by U.S. Standard sieve measure (ASTM D4751-87) is 20-30 mesh.
- 4) Allowable Flow Rate – 40 gallon per minute per square foot (Test Method CRMC GET-2).
- 5) Maximum Particle Size Passing – 0.595 millimeter.
- 6) Mullen Burst Strength – 210 pounds per square inch (ASTM D-3786-80).
- 7) Grab Strength – 120 pounds per square inch.
- 8) Maximum Elongation – 30 percent (ASTM D-1682-64)>
- 9) Silt Fence will be installed by initially cutting a trench approximately six (6”) inches wide by six (6”) inches deep, along the contour for the entire length of installation of the fence. Upon completion of the trench, the silt fence will be stretched along length of the trench with the treated hardwood stakes being driven into the ground approximately two (2’) feet against the upper wall of the trench. The six (6”) inch trench flap will then be laid along the bottom of the trench with compacted fill material. (See attached drawing “SILT FENCE INSTALLATION DETAIL”).
- 10) Prior to the removal of the silt fence, any silt or sediment retained by the silt fence will be seeded with a mixture of both annual and perennial grasses, fertilized and mulched.

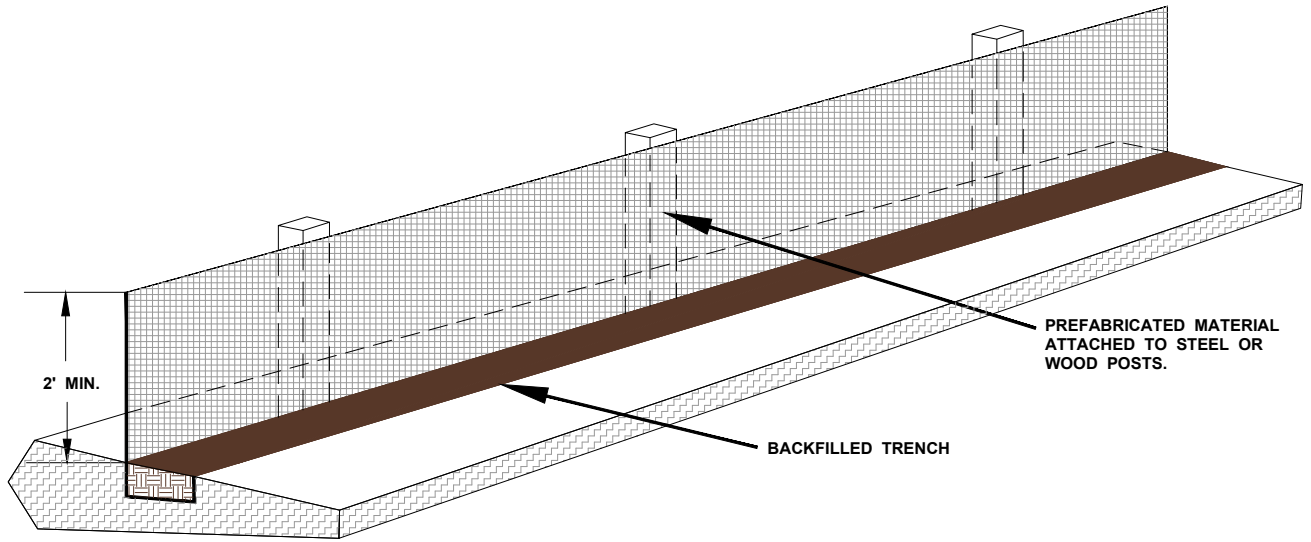

**PREFABRICATED FILTER FENCE DETAIL**

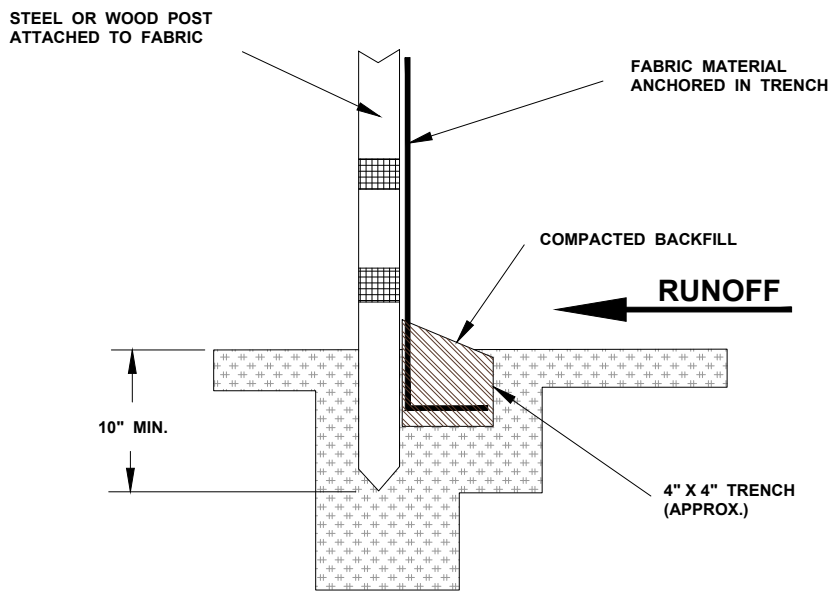

**PREFABRICATED FILTER FENCE DETAIL  
(END VIEW)**

SHEET

1 OF 1

SCALE

NO SCALE

DRAWING:

**GENERAL EROSION CONTROL  
SILT FENCE INSTALLATION DETAIL**

**TASK EMI**  
CONSULTING ENGINEERS  
2832 Monte Deste Drive  
BIRMINGHAM, ALABAMA 35216  
(205) 978-5070

**APPENDIX D**  
**PRIMARY HAUL**  
**ROAD**  
**DESIGN AND CONSTRUCTION SPECIFICATIONS**

## **DESIGN, CONSTRUCTION, MAINTENANCE, AND RECLAMATION SPECIFICATION FOR PRIMARY ROADS**

### **1. LOCATION**

- A) Primary roads will be located on ridges or high areas or on the most stable available slopes so as to control and prevent erosion, siltation, flooding, and adverse impacts to fish and wildlife, or their habitat and related environmental values, to the extent possible.
- B) No part of any primary road will be located in the channel of an intermittent or perennial stream without written approval from the Regulatory Authority.
- C) If at all possible, all primary roads will be located upstream of sediment basins to prevent, control and minimize additional contributions of suspended solids to stream flow or runoff outside the permit area, the violation of applicable State or Federal water quality standards, seriously altering the normal flow of water in stream-beds or drainage channels, and damage to all public or private property.
- D) In instances where it is not possible to locate primary roads in the above manner, sediment control will be achieved by use of silt fences, rock check dams, hay bale berms, etc.

### **2. DESIGN REQUIREMENTS**

- A) Primary roads will be designed by or under the direct supervision of a qualified registered Professional Engineer experienced in the design and construction of roads, in accordance with ADEM rules and regulations, and current, prudent engineering practices. No Primary Road grade will be steeper than fifteen (15%) percent.
- B) All primary roadway embankments will be designed and constructed to be stable under normal construction and operating conditions, with a minimum static safety factor of 1.3.
- C) All primary roads will be design, constructed, reconstructed and maintained to have adequate drainage control structures to safely pass the peak runoff anticipated from a 10 year, 6 hour precipitation event.

### **3. CONSTRUCTION REQUIREMENTS**

- A) The foundation area of the roadbed will be cleared and grubbed of all organic material and the topsoil will be removed. The disturbed area will be kept to the minimum necessary to accommodate the roadbed and/or associated drainage ditch construction.

- B) The road construction material will be suitable subgrade material, free of sod, roots, stumps, etc., and will not contain rocks which exceed twelve (12") inches in diameter. The road construction material will be placed in layers (12 inch maximum thickness) and compacted to ninety five (95%) percent of the standard proctor density, as set forth in ASTM.
- C) The minimum top width of primary roads will under no circumstances be less than sixteen (16') feet and will be of maximum width necessary to facilitate the largest equipment units using the road.
- D) All slopes (cut and fill) will be no steeper than 2 horizontal to 1 vertical (2H:1V), unless specified otherwise in the detailed design.
- E) Roadbeds will be cut into consolidated, non-erodible material or will be surfaced with durable, non-toxic, non-acid forming material. In most instances, durable sandstone overburden material from the mine site will be used for surfacing material. In instances where durable sandstone overburden material from the site is not available or suitable, then durable, non-toxic, non-acid forming material, such as chert, crushed limestone, redrock, and/or crushed sandstone will be hauled in from off-site, place and compacted on the roadbed surface a minimum depth of four (4") inches.
- F) Primary roads will be constructed with grades no steeper than fifteen (15%) percent for no more than 300'.

#### **4. DRAINAGE AND SEDIMENT CONTROL REQUIREMENTS**

- A) Primary roads will be constructed, reconstructed, and maintained to have adequate drainage control, using structures such as, but not limited to bridges, culverts, drainage pipes, ditches, cross drains, and ditch relief drains designed to safely pass the peak runoff anticipated from a 10 year – 6 hour precipitation event. All drainage control structures will be designed and constructed in such a manner whereas, to allow free and operating conditions to prevent, control, and minimize erosion at the inlets and outlets.
- B) Culverts and drainage pipe will be designed and installed to provide adequate support for the load of the largest equipment using the road. For design purposes, "H-20" (live load + impact) will be used. All culverts or drainage pipe with diameters of forty-eight (48") inches or less will be covered with a minimum of one (1') foot and the maximum cover will not exceed fifty-seven (57') feet of desirable compacted material. All culverts or drainage pipe with diameters greater than forty-eight (48") inches will be covered with a minimum of two (2') feet and the maximum cover will not exceed forty-one (41') feet of desirable compacted material.
- C) Culverts and drainage pipe will be designed and installed to allow adequate freeboard to prevent overtopping of the embankment.

- D) Drainage ditches, cross drains, and ditch relief drains will be constructed and maintained to prevent uncontrolled surface drainage over the road surface and roadway embankment.
- E) Drainages ditches will be constructed with no sustained grades greater than five (5%) percent, unless unavoidable. If ditches must be constructed with grades in excess of five (5%) percent, drainage ditches will be lined with riprap.
- F) Sediment control will be achieved by the use of silt fences, rock check dams, hay bale berms, etc. in strategic locations, to prevent excessive siltation to the receiving streams.
- G) Upon completion of construction of all roads, the side slopes of the roadway cut and fill sections, including all borrow areas formed in the construction, areas used for disposal of excess material, ditches, etc. will be seeded with a mixture of perennial and annual grasses, fertilized and mulched to prevent erosion and ensure re-stabilization. Grass mixtures will include, but not be limited to, fescue, Bermuda, rye grass, browntop millet, clover and sericea.

## **5. INSPECTION AND MAINTENANCE REQUIREMENTS**

- A) Routine inspections and maintenance (such as re-grading, re-surfacing, maintenance of sediment control structures, spot replanting, and dust control) will be conducted regularly during the life of each road to assure that each road continually meet design and performance standard.
- B) Dust control will be achieved by the periodic application of water, chemical binders and/or other dust suppressants.
- C) Any road damaged by a catastrophic event, such as a flood, or earthquake, will be repaired as soon as it is practicable after the damage has occurred.

## **6. CERTIFICATION REQUIREMENTS**

- A) Primary roads will be designed by or under the direct supervision of a qualified registered Professional Engineer experienced in the design and construction of roads, in accordance with the ADEM rules and regulations, and current prudent engineering practices. Each design will be certified by a registered Professional Engineer as being designed in accordance with the Regulations of the ADEM.
- B) Upon the completion of the construction of each section of the primary road, as set forth in the detailed design plans, the construction will be certified by a registered Professional Engineer, to ADEM, as being constructed in accordance with these specifications.

## **7. REMOVAL AND RECLAMATION REQUIREMENTS**

- A) All primary roads that are not mined through and remain after the completion of mining may be left as permanent roads for landowner access, if there is no opposition by said landowner.
- B) All primary roads that are not mined through and remain after the completion of mining which are not to be retained as permanent roads for landowner access will be removed and reclaimed as soon as practicable after it is no longer needed for mining and reclamation purposes. This removal and reclamation will include:
  - 1) Closing the road to traffic.
  - 2) Removing all bridges, culverts, drainage pipe, and other drainage control structures, unless otherwise approved as part of the postmining land use.
  - 3) Removing and/or otherwise disposing of road surfacing materials, that are not compatible with the postmining land use and re-vegetation requirements, onsite or removed and stored for re-use.
  - 4) Reshaping and re-grading cut and fill slopes as necessary to be compatible with the postmining land use and to compliment the natural drainage pattern of the surrounding terrain.
  - 5) Protecting the natural drainage patterns by installing dikes or cross-drains as necessary to control surface runoff and erosion.
  - 6) Scarifying or ripping the roadbed, replacing topsoil or substitute material, and revegetating the entire disturbed area.

## **8. TYPICAL ROADBED CONFIGURATION**

- A) See attached drawings, cross-sections, etc. for illustrations of typical roadbed configurations.

# PRIMARY ROAD DETAIL

**PRIMARY ROAD  
TYPICAL CUT SECTION**

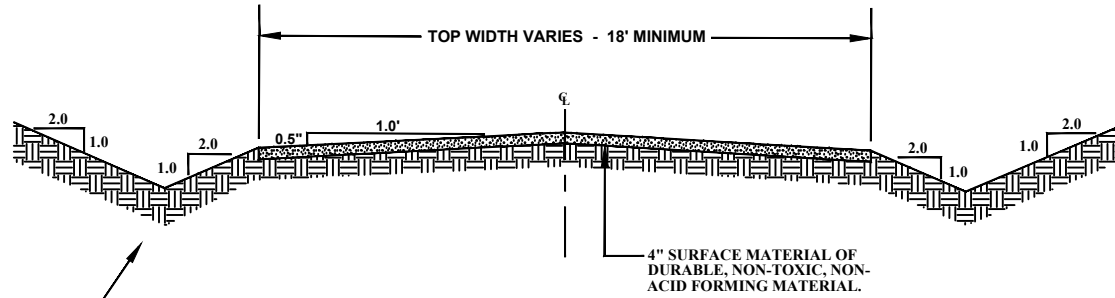

DRAINAGE DITCH TO BE LINED WITH GRASS MIXTURE.  
SEE SPECIFICATIONS, SEE DETAILED DESIGN PLANS  
FOR SPECIFIC DESIGN REQUIREMENTS.

**PRIMARY ROAD  
TYPICAL FILL SECTION**

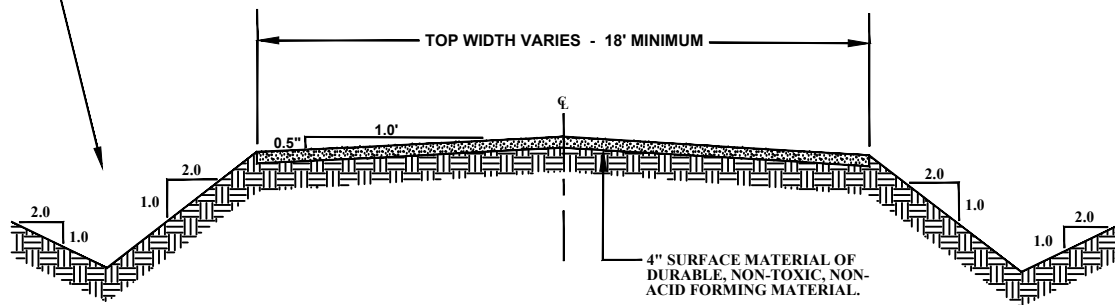

**PRIMARY ROAD  
TYPICAL DRAINAGE DITCH CROSS-SECTION**

MINIMUM DRY FREEBOARD: 0.5'  
MAXIMUM FLOW DEPTH: 2.0'

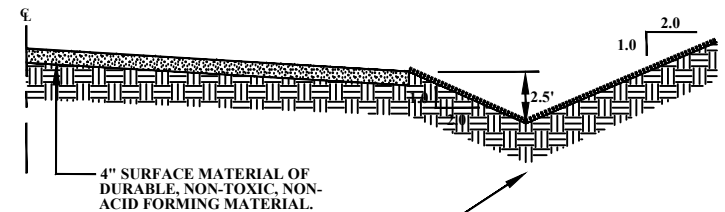

MINIMUM GRADIENT: 0.5%  
MAXIMUM GRADIENT: 10.0%

DRAINAGE DITCH TO BE LINED WITH GRASS MIXTURE.  
SEE SPECIFICATIONS, SEE DETAILED DESIGN PLANS  
FOR SPECIFIC DESIGN REQUIREMENTS.



**APPENDIX E**  
**ROCK FILTER DAM**  
**DESIGN AND CONSTRUCTION SPECIFICATIONS**

## **ROCK FILTER DAM DESIGN CRITERIA**

### **Drainage Area**

The drainage area above the dam shall not exceed 10 acres.

### **Dam Height**

The height of the dam will be limited by the channel bank height or 8 feet, whichever is less. The dam height shall also not exceed the elevation of the upstream property line. Water will bypass over the top of the dam and back slope of the rock dam shall be designed to be stable.

### **Spillway Capacity**

The top of the dam shall be designed to handle the peak runoff from a 10 Year – 24 Hour design storm with a maximum flow depth of 1 foot and freeboard of 1 foot. Therefore the center portion of the dam shall be at least 2 feet lower than the outer edges at the abutment. (See Figure RFD-1 of attached drawing “ROCK FILTER DAM CONSTRUCTION SPECIFICATIONS”).

### **Top Width of Dam**

The minimum top width shall be 6 feet. (See Figure RFD-2 of attached drawing “ROCK FILTER DAM CONSTRUCTION SPECIFICATIONS”).

### **Side Slopes of Dam**

Side slopes shall be 3:1 or flatter on the back slope and 2.5:1 or flatter on the front slope.

### **Outlet Protection**

The downstream toe of the dam shall be protected from erosion by placing a riprap apron at the toe. The apron shall be placed on a zero (0) grade with a riprap thickness of 1.5 feet. The apron shall have a length equal to the height of the dam as a minimum or longer if needed to protect the toe of the dam.

### **Location**

The dam shall be located as closed to the source of sediment as possible and so that it will not cause water to back up onto adjoining property.

### **Basin Requirements**

The basin behind the dam shall provide a surface area that maximizes the sediment trapping efficiency. The basin shall have a sediment storage capacity of 67 cubic yards per acre of drainage area.

### **Riprap Requirements**

Stone for riprap shall consist of field stone or rough unhewn quarry stone of approximately rectangular shape. That stone shall be hard and angular and of such quality that it will not disintegrate on exposure to water or weathering and it shall be suitable in all other aspects for the purpose intended. Riprap shall be Class 1 or better and the dam shall be faced with 1 foot of smaller stone ( $\frac{1}{2}$ " to  $\frac{3}{4}$ " gravel) on the upstream side to increase filtering. (See attached Riprap Classification Specifications.)

**Geotextiles**

Geotextiles shall be used as a separator between the graded stone, the soil base and the abutments. Class I GEOTEX® 1001 or equivalent shall be used. (See attached “GEOTEX® 1001 Product Data Sheet”.) Geotextile mats shall be placed immediately adjacent to the subgrade without any voids between the fabric and the subgrade.

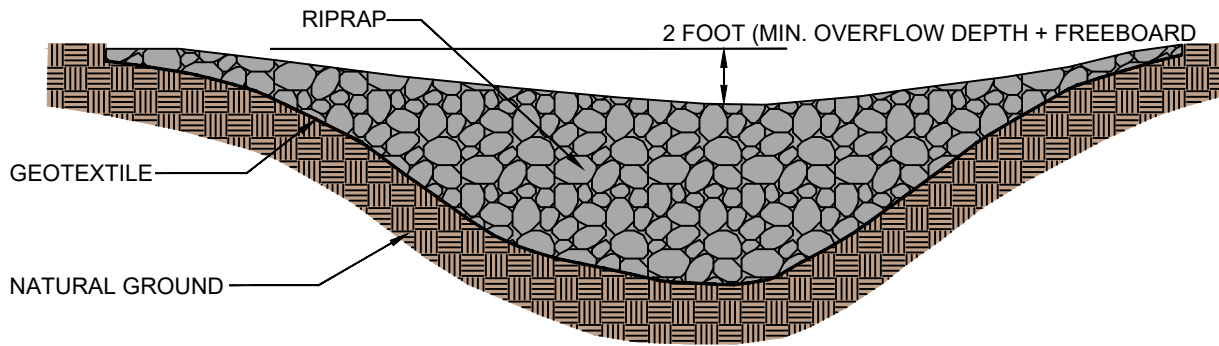

FIGURE RFD-1 TYPICAL FRONT VIEW OF ROCK FILTER DAM

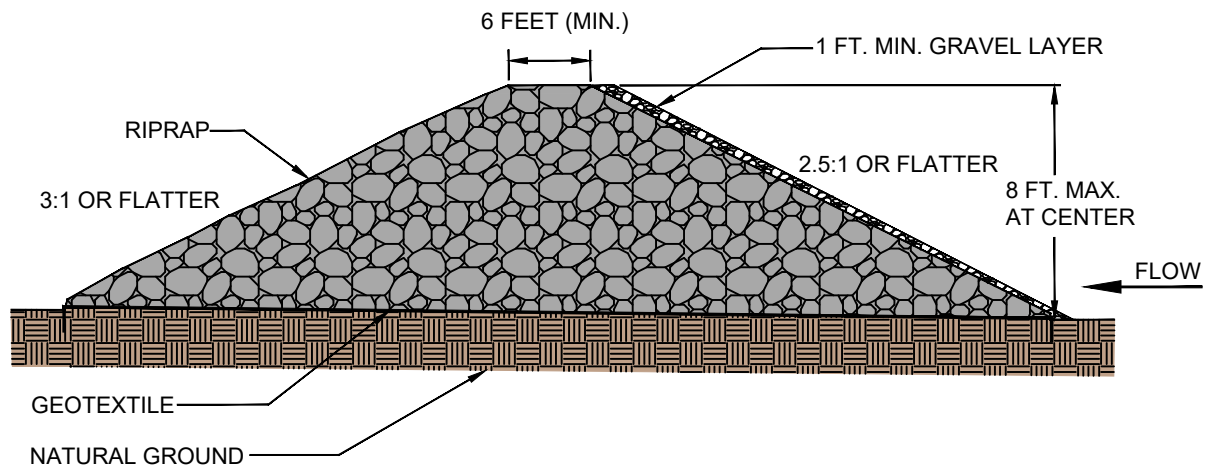

FIGURE RFD-2 TYPICAL SECTION OF ROCK FILTER DAM

SHEET

SCALE

DRAWING:

1 OF 1

NO SCALE

**GENERAL EROSION CONTROL  
ROCK FILTER DAM  
CONSTRUCTION SPECIFICATIONS**

**TASK EMI**  
CONSULTING ENGINEERS  
2832 MONTE DESTO DRIVE  
BIRMINGHAM, ALABAMA 35216  
(205) 978-5070

## **RIPRAP CLASSIFICATION SPECIFICATIONS**

### **CLASS 1 RIPRAP**

No more than 10% of the stone will have a diameter greater than twelve (12) inches; no more than 50% of the stone will have a diameter of less than ten (10) inches; and, no more than 10% of the stone will have a diameter of less than six (6) inches. The thickness of the riprap liner will be no less than twelve (12) inches.

### **CLASS 2 RIPRAP**

No more than 10% of the stone will have a diameter greater than sixteen (16) inches; no more than 50% of the stone will have a diameter of less than twelve (12) inches; and, no more than 10% of the stone will have a diameter of less than six (6) inches. The thickness of the riprap liner will be no less than sixteen (16) inches.

### **CLASS 3 RIPRAP**

No more than 10% of the stone will have a diameter greater than twenty two (22) inches; no more than 50% of the stone will have a diameter of less than sixteen (16) inches; and, no more than 15% of the stone will have a diameter of less than eight (8) inches. The thickness of the riprap liner will be no less than twenty two (22) inches.

### **CLASS 4 RIPRAP**

No more than 10% of the stone will have a diameter greater than twenty seven (27) inches; no more than 50% of the stone will have a diameter of less than twenty two (22) inches; and, no more than 25% of the stone will have a diameter of less than ten (10) inches. The thickness of the riprap liner will be no less than twenty seven (27) inches.

### **CLASS 5 RIPRAP**

No more than 10% of the stone will have a diameter greater than thirty four (34) inches; no more than 50% of the stone will have a diameter of less than twenty seven (27) inches; and, no more than 25% of the stone will have a diameter of less than sixteen (16) inches. The thickness of the riprap liner will be no less than thirty four (34) inches.

GEOTEX<sup>®</sup> 1001 is a polypropylene, staple fiber, needle-punched nonwoven geotextile produced by Propex, and will meet the following Minimum Average Roll Values (MARV) when tested in accordance with the methods listed below. The fibers are needed to form a stable network that retains dimensional stability relative to each other. The geotextile is resistant to ultraviolet degradation and to biological and chemical environments normally found in soils.

GEOTEX<sup>®</sup> 1001 conforms to the property values listed below<sup>1</sup>. Propex performs internal Manufacturing Quality Control (MQC) tests that have been accredited by the Geosynthetic Accreditation Institute – Laboratory Accreditation Program (GAI-LAP). This product is NTPEP approved for AASHTO standards.

MARV<sup>2</sup>

PROPERTY	TEST METHOD	ENGLISH	METRIC
<b>ORIGIN OF MATERIALS</b>			
% U.S. Manufactured		100%	100%
<b>MECHANICAL</b>			
Grab Tensile Strength	ASTM D-4632	250 lbs	1112 N
Grab Elongation	ASTM D-4632	50%	50%
CBR Puncture	ASTM D-6241	700 lbs	3114 N
Trapezoidal Tear	ASTM D-4533	100 lbs	445 N
<b>ENDURANCE</b>			
UV Resistance at 500 hrs	ASTM D-4355	70%	70%
<b>HYDRAULIC</b>			
Apparent Opening Size (AOS) <sup>3</sup>	ASTM D-4751	100 US Std. Sieve	0.150 mm
Permittivity	ASTM D-4491	1.20 sec <sup>-1</sup>	1.20 sec <sup>-1</sup>
Water Flow Rate	ASTM D-4491	80 gpm/ft <sup>2</sup>	3260 l/min/m <sup>2</sup>
<b>ROLL SIZES<sup>4</sup></b>			
		15 ft x 300 ft	4.57 m x 91.5 m

#### NOTES:

1. The property values listed above are effective 04/03/2017 and are subject to change without notice.
2. Values shown are in weaker principal direction. Minimum average roll values (MARV) are calculated as the typical minus two standard deviations. Statistically, it yields a 97.7% degree of confidence that any samples taken from quality assurance testing will exceed the value reported.
3. Maximum average roll value.
4. Contact your local Territory Business Manager (TBM) for custom widths and colors. Lead times may vary depending on customer requirements and volume requested.



ENGINEERED EARTH SOLUTIONS<sup>™</sup>

[www.propexglobal.com](http://www.propexglobal.com)

Propex Operating Company, LLC · 4019 Industry Drive Chattanooga, TN 37416 · ph 800 621 1273 · ph 423 855 1466

ARMORMAX<sup>®</sup>, PYRAMAT<sup>®</sup>, LANDLOK<sup>®</sup>, X3<sup>®</sup>, GEOTEX<sup>®</sup>, PETROMAT<sup>®</sup>, PETROTAC<sup>®</sup>, REFLECTEX<sup>®</sup>, and GRIDPRO<sup>™</sup> are registered trademarks of Propex Operating Company, LLC.

This publication should not be construed as engineering advice. While information contained in this publication is accurate to the best of our knowledge, Propex does not warrant its accuracy or completeness. The ultimate customer and user of the products should assume sole responsibility for the final determination of the suitability of the information and the products for the contemplated and actual use. The only warranty made by Propex for its products is set forth in our product data sheets for the product, or such other written warranty as may be agreed by Propex and individual customers. Propex specifically disclaims all other warranties, express or implied, including without limitation, warranties of merchantability or fitness for a particular purpose, or arising from provision of samples, a course of dealing or usage of trade.

## DESIGN CERTIFICATION STATEMENT

I, Jerry W. Williams, a qualified Registered Professional Engineer, hereby certify that the previous "Pollution Abatement Plan" was developed under my direct supervision and is true and correct to the best of my knowledge and belief.

**TASK ENGINEERING MANAGEMENT INC.**



Jerry W. Williams, P.E.  
Alabama Reg. No. 12739

02-22-26

Date

