



Alabama Department of Environmental Management
adem.alabama.gov

1400 Coliseum Blvd. 36110-2400 ■ Post Office Box 301463
Montgomery, Alabama 36130-1463
(334) 271-7700 ■ FAX (334) 271-7950

MAR 29 2022

Chris H. Davis
President
Davis Materials, Inc.
Post Office Box 1099
Tuscaloosa, AL 35403

RE: Draft Permit
Vance Pit
NPDES Permit No. AL0083917
Tuscaloosa and Bibb County (125 & 009)

Dear Mr. Davis:

Transmitted herein is a draft of the above referenced permit. Please review the enclosed draft permit carefully. If previously permitted, the draft may contain additions/revisions to the language in your current permit. Please submit any comments on the draft permit to the Department within 30 days from the date of receipt of this letter.

Since the Department has made a tentative decision to modify and issue the above referenced permit, ADEM Admin. Code r. 335-6-6-.21 requires a public notice of the draft permit followed by a period of at least 30 days for public comment before the permit can be issued. The United States Environmental Protection Agency will also receive the draft permit for review during the 30-day public comment period.

Any mining, processing, construction, land disturbance, or other regulated activity proposed to be authorized by this draft which does not have permit coverage otherwise is prohibited prior to the effective date of the formal permit. Any discharges from mining or processing activity within the drainage basin associated with each permitted outfall which is conducted prior to Departmental receipt of certification from a professional engineer licensed to practice in the State of Alabama, that the Pollution Abatement/Prevention Plan was implemented according to the design plan, or notification from the Alabama Surface Mining Commission that the sediment control structures have been certified, is prohibited.

Should you have any questions concerning this matter, please contact Jasmine White by email at jasmine.white@adem.alabama.gov or by phone at (334) 270-5622.

Sincerely,

Eric Reidy, Chief
Mining and Natural Resource Section
Stormwater Management Branch
Water Division

EJR/jlw File: DPER/52552

Enclosure

cc: Jasmine White, ADEM
Environmental Protection Agency Region IV
Alabama Department of Conservation and Natural Resources
U.S. Fish and Wildlife Service
Alabama Historical Commission
Advisory Council on Historic Preservation





NATIONAL POLLUTANT DISCHARGE ELIMINATION SYSTEM INDIVIDUAL PERMIT

PERMITTEE: Davis Materials, Inc.
Post Office Box 1099
Tuscaloosa, AL 35403

FACILITY LOCATION: Vance Pit
Story Road
Vance, AL 35490
Tuscaloosa County
T21S, R6W, Sections 17 and 20

PERMIT NUMBER: AL0083917

DSN & RECEIVING STREAM: 001-1 Banks Creek
002-1 Banks Creek
003-1 Unnamed Tributary to Banks Creek

In accordance with and subject to the provisions of the Federal Water Pollution Control Act, as amended, 33 U.S.C. §§1251-1388 (the "FWPCA"), the Alabama Water Pollution Control Act, as amended, Code of Alabama 1975, §§ 22-22-1 to 22-22-14 (the "AWPCA"), the Alabama Environmental Management Act, as amended, Code of Alabama 1975, §§22-22A-1 to 22-22A-17, and rules and regulations adopted thereunder, and subject further to the terms and conditions set forth in this permit, the Permittee is hereby authorized to discharge into the above-named receiving waters.

ISSUANCE DATE:

EFFECTIVE DATE:

EXPIRATION DATE:

**** DRAFT ****

Alabama Department of Environmental Management

MINING AND NATURAL RESOURCE SECTION
NATIONAL POLLUTANT DISCHARGE ELIMINATION SYSTEM (NPDES) PERMIT

TABLE OF CONTENTS

PART I	DISCHARGE LIMITATIONS, CONDITIONS, AND REQUIREMENTS	
A.	DISCHARGE LIMITATIONS AND MONITORING REQUIREMENTS.....	4
B.	REQUIREMENTS TO ACTIVATE A PROPOSED MINING OUTFALL.....	4
C.	DISCHARGE MONITORING AND RECORD KEEPING REQUIREMENTS	4
	1. Sampling Schedule and Frequency.....	4
	2. Measurement Frequency	5
	3. Monitoring Schedule.....	5
	4. Sampling Location.....	6
	5. Representative Sampling	6
	6. Test Procedures	6
	7. Recording of Results	7
	8. Routine Inspection by Permittee.....	7
	9. Records Retention and Production.....	8
	10. Monitoring Equipment and Instrumentation	8
D.	DISCHARGE REPORTING REQUIREMENTS.....	8
	1. Requirements for Reporting of Monitoring.....	8
	2. Requirements for Outfall Certification Summary Submittal.....	10
	3. Noncompliance Notification	10
	1. Reduction, Suspension, or Termination of Monitoring and/or Reporting.....	11
E.	OTHER REPORTING AND NOTIFICATION REQUIREMENTS	12
	1. Anticipated Noncompliance.....	12
	2. Termination of Discharge.....	13
	3. Updating Information	13
	4. Duty to Provide Information	13
F.	SCHEDULE OF COMPLIANCE.....	13
PART II	OTHER REQUIREMENTS, RESPONSIBILITIES, AND DUTIES	
A.	OPERATIONAL AND MANAGEMENT REQUIREMENTS.....	14
	1. Facilities Operation and Management	14
	2. Pollution Abatement and/or Prevention Plan.....	14
	3. Best Management Practices (BMPs).....	14
	4. Biocide Additives.....	15
	5. Facility Identification.....	16
	6. Removed Substances.....	16
	7. Loss or Failure of Treatment Facilities	16
	8. Duty to Mitigate.....	16
B.	BYPASS AND UPSET	16
	1. Bypass.....	16
	2. Upset.....	17
C.	PERMIT CONDITIONS AND RESTRICTIONS.....	17
	1. Prohibition against Discharge from Facilities Not Certified	18
	2. Permit Modification, Suspension, Termination, and Revocation	19
	3. Automatic Expiration of Permits for New or Increased Discharges.....	19
	4. Transfer of Permit.....	20
	5. Groundwater	20

6. Property and Other Rights.....	20
D. RESPONSIBILITIES	21
1. Duty to Comply	21
2. Change in Discharge	21
3. Compliance with Toxic or Other Pollutant Effluent Standard or Prohibition.....	22
4. Compliance with Water Quality Standards and Other Provisions.....	22
5. Compliance with Statutes and Rules	22
6. Right of Entry and Inspection.....	23
7. Duty to Reapply or Notify of Intent to Cease Discharge.....	23
PART III ADDITIONAL REQUIREMENTS, CONDITIONS, AND LIMITATIONS	
A. CIVIL AND CRIMINAL LIABILITY.....	24
1. Tampering.....	24
2. False Statements	24
3. Permit Enforcement	24
4. Relief From Liability.....	24
B. OIL AND HAZARDOUS SUBSTANCE LIABILITY	24
C. AVAILABILITY OF REPORTS.....	24
D. DEFINITIONS	24
E. SEVERABILITY.....	29
F. PROHIBITIONS AND ACTIVITIES NOT AUTHORIZED.....	29
G. DISCHARGES TO IMPAIRED WATERS	29

PART I DISCHARGE LIMITATIONS, CONDITIONS, AND REQUIREMENTS

A. DISCHARGE LIMITATIONS AND MONITORING REQUIREMENTS

During the period beginning on the effective date of this Permit and lasting through the expiration date of this Permit, the Permittee is authorized to discharge from each point source identified on Page 1 of this Permit and described more fully in the Permittee's application, if the outfalls have been constructed and certified. Discharges shall be limited and monitored by the Permittee as specified below:

Parameter	Discharge Limitations			Monitoring Requirements	
	Daily Minimum	Monthly Average	Daily Maximum	Sample Type	Measurement Frequency ¹
pH (Outfall 001 and 003) 00400	6.0 s.u.	-----	8.5 s.u.	Grab	2/Month
pH (Outfall 002) 00400	6.0 s.u.	-----	9.0 s.u.	Grab	2/Month
Solids, Total Suspended 00530	-----	25.0 mg/L	45.0 mg/L	Grab	2/Month
Flow, In Conduit or Thru Treatment Plant ² 50050	-----	Report MGD	Report MGD	Instantaneous	2/Month

B. REQUIREMENTS TO ACTIVATE A PROPOSED MINING OUTFALL

1. Discharge from any point source identified on Page 1 of this Permit which is a proposed outfall is not authorized by this Permit until the outfall has been constructed and certification received by the Department from a professional engineer, registered in the State of Alabama, certifying that such facility has been constructed according to good engineering practices and in accordance with the Pollution Abatement and/or Prevention (PAP) Plan.
2. Certification required by Part I.B.1. shall be submitted on a completed ADEM Form 432. The certification shall include the latitude and longitude of the constructed and certified outfall.
3. Discharge monitoring and Discharge Monitoring Report (DMR) reporting requirements described in Part I.C. of this Permit do not apply to point sources that have not been constructed and certified.
4. Upon submittal of the certification required by Part I.B.1. to the Department, all monitoring and DMR submittal requirements shall apply to the constructed and certified outfall.

C. DISCHARGE MONITORING AND RECORD KEEPING REQUIREMENTS

1. **Sampling Schedule and Frequency**
 - a. The Permittee shall collect at least one grab sample of the discharge to surface waters from each constructed and certified point source identified on Page 1 of this Permit and described more fully in the Permittee's application twice per month at a rate of at least

¹ See Part I.C.2. for further measurement frequency requirements.

² Flow must be determined at the time of sample collection by direct measurement, calculation, or other method acceptable to the Department.

- every other week if a discharge occurs at any time during the two week period, but need not collect more than two samples per calendar month. Each sample collected shall be analyzed for each parameter specified in Part I.A. of this Permit.
- b. If the final effluent is pumped in order to discharge (e.g. from incised ponds, old highwall cuts, old pit areas or depressions, etc.), the Permittee shall collect at least one grab sample of the discharge from each point source identified on Page 1 of this Permit and described more fully in the Permittee's application each quarterly (three month) monitoring period if a discharge occurs at any time during the quarterly monitoring period which results from direct pumped drainage. Each sample collected shall be analyzed for each parameter specified in Part I.A. of this Permit.
 - c. The Permittee may increase the frequency of sampling listed in Parts I.C.1.a and I.C.1.b; however, all sampling results must be reported to the Department and included in any calculated results submitted to the Department in accordance with this Permit.

2. Measurement Frequency

Measurement frequency requirements found in Part I.A. shall mean:

- a. A measurement frequency of one day per week shall mean sample collection on any day of discharge which occurs every calendar week.
- b. A measurement frequency of two days per month shall mean sample collection on any day of discharge which occurs every other week, but need not exceed two sample days per month.
- c. A measurement frequency of one day per month shall mean sample collection on any day of discharge which occurs during each calendar month.
- d. A measurement frequency of one day per quarter shall mean sample collection on any day of discharge which occurs during each calendar quarter.
- e. A measurement frequency of one day per six months shall mean sample collection on any day of discharge which occurs during the period of January through June and during the period of July through December.
- f. A measurement frequency of one day per year shall mean sample collection on any day of discharge which occurs during each calendar year.

3. Monitoring Schedule

The Permittee shall conduct the monitoring required by Part I.A. in accordance with the following schedule:

- a. MONITORING REQUIRED MORE FREQUENTLY THAN MONTHLY AND MONTHLY shall be conducted during the first full month following the effective date of coverage under this Permit and every month thereafter. More frequently than monthly and monthly monitoring may be done anytime during the month, unless restricted elsewhere in this Permit, but the results should be reported on the last Discharge Monitoring Report (DMR) due for the quarter (i.e., with the March, June, September, and December DMRs).
- b. QUARTERLY MONITORING shall be conducted at least once during each calendar quarter. Calendar quarters are the periods of January through March, April through June, July through September, and October through December. The Permittee shall conduct the quarterly monitoring during the first complete calendar quarter following the effective

date of this Permit and is then required to monitor once during each quarter thereafter. Quarterly monitoring may be done anytime during the quarter, unless restricted elsewhere in this Permit, but the results should be reported on the last DMR due for the quarter (i.e., with the March, June, September, and December DMRs).

- c. SEMIANNUAL MONITORING shall be conducted at least once during the period of January through June and at least once during the period of July through December. The Permittee shall conduct the semiannual monitoring during the first complete semiannual calendar period following the effective date of this Permit and is then required to monitor once during each semiannual period thereafter. Semiannual monitoring may be done anytime during the semiannual period, unless restricted elsewhere in this Permit, but it should be reported on the last DMR due for the month of the semiannual period (i.e., with the June and December DMRs).
- d. ANNUAL MONITORING shall be conducted at least once during the period of January through December. The Permittee shall conduct the annual monitoring during the first complete calendar annual period following the effective date of this Permit and is then required to monitor once during each annual period thereafter. Annual monitoring may be done anytime during the year, unless restricted elsewhere in this Permit, but it should be reported on the December DMR.

4. Sampling Location

Unless restricted elsewhere in this Permit, samples collected to comply with the monitoring requirements specified in Part I.A. shall be collected at the nearest accessible location just prior to discharge and after final treatment, or at an alternate location approved in writing by the Department.

5. Representative Sampling

Sample collection and measurement actions taken as required herein shall be representative of the volume and nature of the monitored discharge and shall be in accordance with the provisions of this Permit.

6. Test Procedures

For the purpose of reporting and compliance, Permittees shall use one of the following procedures:

- a. For parameters with an EPA established Minimum Level (ML), report the measured value if the analytical result is at or above the ML and report "0" for values below the ML. Test procedures for the analysis of pollutants shall conform to 40 CFR Part 136, guidelines published pursuant to Section 304(h) of the FWPCA, 33 U.S.C. Section 1314(h), and ADEM Standard Operating Procedures. If more than one method for analysis of a substance is approved for use, a method having a minimum level lower than the permit limit shall be used. If the minimum level of all methods is higher than the permit limit, the method having the lowest minimum level shall be used and a report of less than the minimum level shall be reported as zero and will constitute compliance, however should EPA approve a method with a lower minimum level during the term of this Permit the Permittee shall use the newly approved method.
- b. For pollutant parameters without an established ML, an interim ML may be utilized. The interim ML shall be calculated as 3.18 times the Method Detection Level (MDL) calculated pursuant to 40 CFR Part 136, Appendix B.

Permittees may develop an effluent matrix-specific ML, where an effluent matrix prevents attainment of the established ML. However, a matrix specific ML shall be based

upon proper laboratory method and technique. Matrix-specific MLs must be approved by the Department, and may be developed by the Permittee during permit issuance, reissuance, modification, or during compliance schedule.

In either case the measured value should be reported if the analytical result is at or above the ML and "0" reported for values below the ML.

- c. For parameters without an EPA established ML, interim ML, or matrix-specific ML, a report of less than the detection limit shall constitute compliance if the detection limit of all analytical methods is higher than the permit limit using the most sensitive EPA approved method. For the purpose of calculating a monthly average, "0" shall be used for values reported less than the detection limit.

The Minimum Level utilized for procedures identified in Parts I.C.6.a. and b. shall be reported on the Permittee's DMR. When an EPA approved test procedure for analysis of a pollutant does not exist, the Director shall approve the procedure to be used.

7. Recording of Results

For each measurement or sample taken pursuant to the requirements of this Permit, the Permittee shall record the following information:

- a. The facility name and location, point source number, date, time, and exact place of sampling or measurements;
- b. The name(s) of person(s) who obtained the samples or measurements;
- c. The dates and times the analyses were performed;
- d. The name(s) of the person(s) who performed the analyses;
- e. The analytical techniques or methods used including source of method and method number; and
- f. The results of all required analyses.

8. Routine Inspection by Permittee

- a. The Permittee shall inspect all point sources identified on Page 1 of this Permit and described more fully in the Permittee's application and all treatment or control facilities or systems used by the Permittee to achieve compliance with the terms and conditions of this Permit at least as often as the applicable sampling frequency specified in Part I.C.1 of this Permit.
- b. If required by the Director, the Permittee shall maintain a written log for each point source identified on Page 1 of this Permit and described more fully in the Permittee's application in which the Permittee shall record the following information:
 - (1) The date and time the point source and any associated treatment or control facilities or systems were inspected by the Permittee;
 - (2) Whether there was a discharge from the point source at the time of inspection by the Permittee;
 - (3) Whether a sample of the discharge from the point source was collected at the time of inspection by the Permittee;

- (4) Whether all associated treatment or control facilities or systems appeared to be in good working order and operating as efficiently as possible, and if not, a description of the problems or deficiencies; and
- (5) The name and signature of the person performing the inspection of the point source and associated treatment or control facilities or systems.

9. Records Retention and Production

- a. The Permittee shall retain records of all monitoring information, including all calibration and maintenance records and all original strip chart recordings for continuous monitoring instrumentation, copies of all reports required by this Permit, and records of all data used to complete the above reports or the application for this Permit, for a period of at least three (3) years from the date of the sample collection, measurement, report, or application. This period may be extended by request of the Director at any time. If litigation or other enforcement action, under the AWPCA, AEMA, and/or the FWPCA, is ongoing which involves any of the above records, the records shall be kept until the litigation is resolved. Upon the written request of the Director, the Permittee shall provide the Director with a copy of any record required to be retained by this paragraph. Copies of these records should not be submitted unless requested.
- b. All records required to be kept for a period of three (3) years shall be kept at the permitted facility or an alternate location approved by the Department in writing and shall be available for inspection.

10. Monitoring Equipment and Instrumentation

All equipment and instrumentation used to determine compliance with the requirements of this Permit shall be installed, maintained, and calibrated in accordance with the manufacturer's instructions or, in the absence of manufacturer's instructions, in accordance with accepted practices. The Permittee shall develop and maintain quality assurance procedures to ensure proper operation and maintenance of all equipment and instrumentation. The quality assurance procedures shall include the proper use, maintenance, and installation, when appropriate, of monitoring equipment at the plant site.

D. DISCHARGE REPORTING REQUIREMENTS

1. Requirements for Reporting of Monitoring

- a. Monitoring results obtained during the previous three (3) months shall be summarized for each month on a Discharge Monitoring Report (DMR) Form approved by the Department, and submitted to the Department so that it is received by the Director no later than the 28th day of the month following the quarterly reporting period (i.e., on the 28th day of January, April, July, and October of each year).
- b. The Department utilizes a web-based electronic reporting system for submittal of DMRs. **Except as allowed by Part I.G.1.c. or d., the Permittee shall submit all DMRs required by Part I.G.1.a. by utilizing the Department's current electronic reporting system.** The Department's current reporting system, Alabama Environmental Permitting and Compliance System (AEPACS), can be found online at <https://aepacs.adem.alabama.gov/nviro/ncore/external/home>.
- c. If the electronic reporting system is down (i.e. electronic submittal of DMR data is unable to be completed due to technical problems originating with the Department's system; this

could include entry/submittal issues with an entire set of DMRs or individual parameters), permittees are not relieved of their obligation to submit DMR data to the Department by the required submittal date. However, if the electronic reporting system is down on the 28th day of the month or is down for an extended period of time as determined by the Department when a DMR is required to be submitted, the facility may submit the data in an alternate manner and format acceptable to the Department. Preapproved alternate acceptable methods include faxing, e-mailing, mailing, or hand-delivery of data such that they are received by the required reporting date. Within five calendar days of the electronic reporting system resuming operation, the Permittee shall enter the data into the reporting system unless an alternate timeframe is approved by the Department. An attachment should be included with the electronic DMR submittal verifying the original submittal date (date of the fax, copy of dated e-mail, or hand-delivery stamped date).

- d. The permittee may submit a request to the Department for a temporary electronic reporting waiver for DMR submittals. The waiver request should include the permit number; permittee name; facility/site name; facility address; name, address, and contact information for the responsible official or duly authorized representative; a detailed statement regarding the basis for requesting such a waiver; and the duration for which the waiver is requested. Approved electronic reporting waivers are not transferrable. Permittees with an approved electronic reporting waiver for DMRs may submit hard copy DMRs for the period that the approved electronic reporting waiver request is effective. The Permittee shall submit the Department-approved DMR forms to the address listed in Part I.G.1.i.
- e. If the Permittee, using approved analytical methods as specified in Part I.F.6., monitors any discharge from a point source identified on Page 1 of this Permit and describe more fully in the Permittee's application more frequently than required by this Permit; the results of such monitoring shall be included in the calculation and reporting of values on the DMR Form, and the increased frequency shall be indicated on the DMR Form.
- f. In the event no discharge from a point source identified on Page 1 of this Permit and described more fully in the Permittee's application occurs during a monitoring period, the Permittee shall report "No Discharge" for such period on the appropriate DMR Form.
- g. Each DMR Form submitted by the Permittee to the Department in accordance with Part I.G.1. must be legible and bear an original signature or electronic signature. Photo and electronic copies of the signature are not acceptable and shall not satisfy the reporting requirements of this Permit.
- h. All reports and forms required to be submitted by this Permit, the AWPCA, and the Department's rules and regulations, shall be signed by a "responsible official" of the Permittee as defined in ADEM Admin. Code r. 335-6-6-.09 or a "duly authorized representative" of such official as defined in ADEM Admin. Code r. 335-6-6-.09 and shall bear the following certification:

"I certify under penalty of law that this document and all attachments were prepared under my direction or supervision in accordance with a system designed to assure that qualified personnel properly gather and evaluate the information submitted. Based on my inquiry of the person or persons who manage the system, or those persons directly responsible for gathering the information, the information submitted is, to the best of my knowledge and belief, true, accurate, and complete. I am aware that there are significant penalties for submitting false information, including the possibility of fine and imprisonment for knowing violations."

- i. All DMRs, reports, and forms required to be submitted by this Permit, the AWPCA and the Department's rules and regulations, shall be submitted through the Department's electronic reporting system, AEPACS, or, if in hardcopy, shall be addressed to:

Alabama Department of Environmental Management
Water Division, Mining and Natural Resource Section
Post Office Box 301463
Montgomery, Alabama 36130-1463

Certified and Registered Mail shall be addressed to:

Alabama Department of Environmental Management
Water Division, Mining and Natural Resource Section
1400 Coliseum Boulevard
Montgomery, Alabama 36110-2059

- j. Unless authorized in writing by the Department, approved reporting forms required by this Permit or the Department are not to be altered, and if copied or reproduced, must be consistent in format and identical in content to the ADEM approved form. Unauthorized alteration, falsification, or use of incorrectly reproduced forms constitutes noncompliance with the requirements of this Permit and may significantly delay processing of any request, result in denial of the request, result in permit termination, revocation, suspension, modification, or denial of a permit renewal application, or result in other enforcement action.
- k. If this Permit is a reissuance, then the Permittee shall continue to submit DMRs in accordance with the requirements of their previous permit until such time as DMRs are due as discussed in Part I.G.1.

2. Requirements for Outfall Certification Summary Submittal

The Permittee shall submit as an attachment to the certification required by Part I.B.1, an Outfall Certification Summary in a format approved or provided by the Department. The Outfall Certification Summary shall indicate whether each outfall identified on Page 1 of this Permit has been certified and, if so, it shall include the date for each certification as well as the latitude and longitude of the certified outfall. If any outfall identified on Page 1 of this Permit has received written approval from the Department pursuant to Part IV.C. of this Permit stating that the Permittee may utilize the Post-Mining Discharge Limitations specified in Part I.A.3., then the list of outfalls shall include the date of the Post-Mining Discharge Limitations approval. If any outfall identified on Page 1 of this Permit has been released from monitoring requirements as provided in Part I.D.4. of this Permit, then the list of outfalls shall include the date of the monitoring requirement release.

3. Noncompliance Notification

- a. The Permittee must notify the Department if, for any reason, the Permittee's discharge:
- (1) Potentially threatens human health or welfare;
 - (2) Potentially threatens fish or aquatic life;
 - (3) Causes an in-stream water quality criterion to be exceeded;

- (4) Does not comply with an applicable toxic pollutant effluent standard or prohibition established under Section 307(a) of the FWPCA, 33 U.S.C. §1317(a);
- (5) Contains a quantity of a hazardous substance which has been determined may be harmful to the public health or welfare under Section 311(b)(4) of the FWPCA, 33 U.S.C. §1321(b)(4); or
- (6) Exceeds any discharge limitation for an effluent parameter as a result of an unanticipated bypass or upset.

The Permittee shall orally or electronically report any of the above occurrences, describing the circumstances and potential effects of such discharge to the Director within 24-hours after the Permittee becomes aware of the occurrence of such discharge. In addition to the oral or electronic report, the Permittee shall submit to the Director a written report as provided in Part I.D.2.c., no later than five (5) days after becoming aware of the occurrence of such discharge.

- b. If for any reason, the Permittee's discharge does not comply with any limitation of this Permit, the Permittee shall submit a written report to the Director as provided in Part I.D.2.c. This report must be submitted with the next Discharge Monitoring Report required to be submitted by Part I.D.1. of this Permit after becoming aware of the occurrence of such noncompliance.
- c. Any written report required to be submitted to the Director in accordance with Parts I.D.2.a. and b. shall be submitted using a Noncompliance Notification Form (ADEM Form 421) available on the Department's website (<http://adem.alabama.gov/DeptForms/Form421.pdf>) and include the following information:
 - (1) A description of the discharge and cause of noncompliance;
 - (2) The period of noncompliance, including exact dates and times, or if not corrected, the anticipated time the noncompliance is expected to continue; and
 - (3) A description of the steps taken and/or being taken to reduce or eliminate the noncomplying discharge and to prevent its recurrence.

1. Reduction, Suspension, or Termination of Monitoring and/or Reporting

- a. The Director may, with respect to any point source identified on Page 1 of this Permit and described more fully in the Permittee's application, authorize the Permittee to reduce, suspend, or terminate the monitoring and/or reporting required by this Permit upon the submission of a written request for such reduction, suspension, or termination by the Permittee provided:
 - (1) All mining, processing, or disturbance in the drainage basin(s) associated with the discharge has ceased and site access is adequately restricted or controlled to preclude unpermitted and unauthorized mining, processing, transportation, or associated operations/activity;
 - (2) Permanent, perennial vegetation has been re-established on all areas mined or disturbed for at least one year since mining has ceased in the drainage basin(s) associated with the surface discharge, or all areas have been permanently graded such that all drainage is directed back into the mined pit to preclude all surface discharges;

- (3) Unless waived in writing by the Department, the Permittee has been granted, in writing, a 100% Bond Release, if applicable, by the Alabama Department of Industrial Relations and, if applicable, by the Surface Mining Commission for all areas mined or disturbed in the drainage basin(s) associated with the discharge;
 - (4) Unless waived in writing by the Department, the Permittee has submitted inspection reports prepared and certified by a Professional Engineer (PE) registered in the State of Alabama or a qualified professional under the PE's direction which certify that the facility has been fully reclaimed or that water quality remediation has been achieved. The first inspection must be conducted approximately one year prior to and the second inspection must be conducted within thirty days of the Permittee's request for termination of monitoring and reporting requirements;
 - (5) All surface effects of the mining activity such as fuel or chemical tanks, preparation plants or equipment, old tools or equipment, junk or debris, etc., must be removed and disposed of according to applicable state and federal regulations;
 - (6) The Permittee's request for termination of monitoring and reporting requirements contained in this Permit has been supported by monitoring data covering a period of at least six consecutive months or such longer period as is necessary to assure that the data reflect discharges occurring during varying seasonal climatological conditions;
 - (7) The Permittee has stated in its request that the samples collected and reported in the monitoring data submitted in support of the Permittee's request for monitoring termination or suspension are representative of the discharge and were collected in accordance with all Permit terms and conditions respecting sampling times (e.g., rainfall events) and methods and were analyzed in accordance with all Permit terms and conditions respecting analytical methods and procedures;
 - (8) The Permittee has certified that during the entire period covered by the monitoring data submitted, no chemical treatment of the discharge was provided;
 - (9) The Permittee's request has included the certification required by Part I.D.1.e. of this Permit; and
 - (10) The Permittee has certified to the Director in writing as part of the request, its compliance with (1) through (9) above.
- b. It remains the responsibility of the Permittee to comply with the monitoring and reporting requirements of this Permit until written authorization to reduce, suspend, or terminate such monitoring and/or reporting is received by the Permittee from the Director.

E. OTHER REPORTING AND NOTIFICATION REQUIREMENTS

1. Anticipated Noncompliance

The Permittee shall give the Director written advance notice of any planned changes or other circumstances regarding a facility which may result in noncompliance with permit requirements.

2. Termination of Discharge

The Permittee shall notify the Director, in writing, when all discharges from any point source(s) identified on Page 1 of this Permit and described more fully in the Permittee's application have permanently ceased.

3. Updating Information

- a. The Permittee shall inform the Director of any change in the Permittee's mailing address or telephone number or in the Permittee's designation of a facility contact or officer(s) having the authority and responsibility to prevent and abate violations of the AWPCA, the AEMA, the Department's rules and regulations, and the terms and conditions of this Permit, in writing, no later than ten (10) days after such change. Upon request of the Director, the Permittee shall furnish the Director with an update of any information provided in the permit application.
- b. If the Permittee becomes aware that it failed to submit any relevant facts in a permit application, or submitted incorrect information in a permit application or in any report to the Director, it shall promptly submit such facts or information with a written explanation for the mistake and/or omission.

4. Duty to Provide Information

- a. The Permittee shall furnish to the Director, within a reasonable time, any information which the Director may request to determine whether cause exists for modifying, suspending, terminating, or revoking and reissuing this Permit, in whole or in part, or to determine compliance with this Permit. The Permittee shall also furnish to the Director upon request, copies of records required to be maintained by this Permit.
- b. The Permittee shall furnish to the Director upon request, within a reasonable time, available information (name, phone number, address, and site location) which identifies offsite sources of material or natural resources (mineral, ore, or other material such as iron, coal, coke, dirt, chert, shale, clay, sand, gravel, bauxite, rock, stone, etc.) used in its operation or stored at the facility.

F. SCHEDULE OF COMPLIANCE

The Permittee shall achieve compliance with the discharge limitations specified in Part I.A. of this Permit in accordance with the following schedule:

Compliance must be achieved by the effective date of this Permit.

PART II OTHER REQUIREMENTS, RESPONSIBILITIES, AND DUTIES

A. OPERATIONAL AND MANAGEMENT REQUIREMENTS

1. Facilities Operation and Management

The Permittee shall at all times operate and maintain all facilities and systems of treatment and control (and related appurtenances) which are installed or used by the Permittee to achieve compliance with the conditions of this Permit. Proper operation and maintenance includes effective performance, adequate funding, adequate operator staffing and training, and adequate laboratory and process controls, including appropriate quality assurance procedures. This provision requires the operation of backup or auxiliary facilities only when necessary to achieve compliance with the conditions of this Permit.

2. Pollution Abatement and/or Prevention Plan

The Pollution Abatement and/or Prevention (PAP) Plan shall be prepared and certified by a registered Professional Engineer (PE), licensed to practice in the State of Alabama, and shall include at a minimum, the information indicated in ADEM Admin. Code r. 335-6-9-.03 and ADEM Admin. Code ch. 335-6-9 Appendices A and B. The PAP Plan shall become a part of this Permit and all requirements of the PAP Plan shall become requirements of this Permit pursuant to ADEM Admin. Code r. 335-6-9-.05(2).

3. Best Management Practices (BMPs)

a. Unless otherwise authorized in writing by the Director, the Permittee shall provide a means of subsurface withdrawal for any discharge from each point source identified on Page 1 of this Permit and described more fully in the Permittee's application. Notwithstanding the above provision, a means of subsurface withdrawal need not be provided for any discharge caused by a 24-hour precipitation event greater than a 10-year, 24-hour precipitation event.

b. Dilution water shall not be added to achieve compliance with discharge limitations except when the Director has granted prior written authorization for dilution to meet water quality requirements.

c. The Permittee shall minimize the contact of water with overburden, including but not limited to stabilizing disturbed areas through grading, diverting runoff, achieving quick growing stands of temporary vegetation, sealing acid-forming and toxic-forming materials, and maximizing placement of waste materials in back-fill areas.

d. The Permittee shall prepare, submit to the Department for approval, and implement a Best Management Practices (BMPs) Plan for containment of any or all process liquids or solids, in a manner such that these materials do not present a potential for discharge, if so required by the Director. When submitted and approved, the BMP Plan shall become a part of this Permit and all requirements of the BMP Plan shall become requirements of this Permit.

e. Spill Prevention, Control, and Management

The Permittee shall prepare, implement, and maintain a Spill Prevention, Control and Countermeasures (SPCC) Plan acceptable to the Department that is prepared and certified by a Professional Engineer (PE), registered in the State of Alabama, for all onsite petroleum product or other pollutant storage tanks or containers as required by applicable state (ADEM Admin. Code r. 335-6-6-.12(r)) and federal (40 C.F.R. §§112.1-.7)

regulations. The Permittee shall implement appropriate structural and/or non-structural spill prevention, control, and/or management sufficient to prevent any spills of pollutants from entering a ground or surface water of the State or a publicly or privately owned treatment works. Careful consideration should be applied for tanks or containers located near treatment ponds, water bodies, or high traffic areas. In most situations this would require construction of a containment system if the cumulative storage capacity of petroleum products or other pollutants at the facility is greater than 1320 gallons. Any containment system used to implement this requirement shall be constructed of materials compatible with the substance(s) contained and shall prevent the contamination of groundwater. Such containment systems shall be capable of retaining a volume equal to 110 percent of the capacity of the largest tank for which containment is provided. The applicant shall maintain onsite or have readily available flotation booms to contain, and sufficient material to absorb, fuel and chemical spills and leaks. Soil contaminated by chemical spills, oil spills, etc., must be immediately cleaned up or be removed and disposed of in an approved manner.

- f. All surface drainage and storm water runoff which originate within or enters the Permittee's premises and which contains any pollutants or other wastes shall be discharged, if at all, from a point source identified on Page 1 of this Permit and described more fully in the Permittee's application.
- g. The Permittee shall take all reasonable precautions to prevent any surface drainage or storm water runoff which originates outside the Permittee's premises and which contains any pollutants or other wastes from entering the Permittee's premises. At no time shall the Permittee discharge any such surface drainage or storm water runoff which enters the Permittee's premises if, either alone or in combination with the Permittee's effluent, the discharge would exceed any applicable discharge limitation specified in Part I.A. of this Permit.

4. Biocide Additives

- a. The Permittee shall notify the Director in writing not later than sixty (60) days prior to instituting the use of any biocide corrosion inhibitor or chemical additive in any cooling or boiler system(s) regulated by this Permit. Notification is not required for additives that should not reasonably be expected to cause the cooling water or boiler water to exhibit toxicity as determined by analysis of manufacturer's data or testing by the Permittee. Such notification shall include:
 - (a) Name and general composition of biocide or chemical;
 - (b) 96-hour median tolerance limit data for organisms representative of the biota of the water(s) which the discharge(s) enter(s);
 - (c) Quantities to be used;
 - (d) Frequencies of use;
 - (e) Proposed discharge concentrations; and
 - (f) EPA registration number, if applicable.
- b. The use of any biocide or chemical additive containing tributyl tin, tributyl tin oxide, zinc, chromium, or related compounds in any cooling or boiler system(s) regulated by the Permit is prohibited except as exempted below. The use of a biocide or additive containing zinc, chromium or related compounds may be used in special circumstances if (1) the permit contains limits for these substances, or (2) the applicant demonstrates

during the application process that the use of zinc, chromium or related compounds as a biocide or additive will not pose a reasonable potential to violate the applicable State water quality standards for these substances. The use of any additive, not identified in this Permit or in the application for this Permit or not exempted from notification under this Permit is prohibited, prior to a determination by the Department that permit modification to control discharge of the additive is not required or prior to issuance of a permit modification controlling discharge of the additive.

5. Facility Identification

The Permittee shall clearly display prior to commencement of any regulated activity and until permit coverage is properly terminated, the name of the Permittee, entire NPDES permit number, facility or site name, and other descriptive information deemed appropriate by the Permittee at an easily accessible location(s) to adequately identify the site, unless approved otherwise in writing by the Department. The Permittee shall repair or replace the sign(s) as necessary upon becoming aware that the identification is missing or is unreadable due to age, vandalism, theft, weather, or other reason.

6. Removed Substances

Solids, sludges, filter backwash, or any other pollutants or other wastes removed in the course of treatment or control of wastewaters shall be disposed of in a manner that complies with all applicable Department rules and regulations.

7. Loss or Failure of Treatment Facilities

Upon the loss or failure of any treatment facility, including but not limited to the loss or failure of the primary source of power of the treatment facility, the Permittee shall, where necessary to maintain compliance with the discharge limitations specified in Part I.A. of this Permit or any other terms or conditions of this Permit, cease, reduce, or otherwise control production and/or discharges until treatment is restored.

8. Duty to Mitigate

The Permittee shall promptly take all reasonable steps to minimize or prevent any violation of this Permit or to mitigate and minimize any adverse impact to waters resulting from noncompliance with any discharge limitation specified in Part I.A. of this Permit, including such accelerated or additional monitoring of the discharge and/or the receiving waterbody as is necessary to determine the nature and impact of the noncomplying discharge.

B. BYPASS AND UPSET

1. Bypass

- a. Any bypass is prohibited except as provided in Parts II.B.1.b. and c.
- b. A bypass is not prohibited if:
 - (1) It does not cause any applicable discharge limitation specified in Part I.A. of this Permit to be exceeded;
 - (2) The discharge resulting from such bypass enters the same receiving water as the discharge from the permitted outfall;

- (3) It is necessary for essential maintenance of a treatment or control facility or system to assure efficient operation of such facility or system; and
 - (4) The Permittee monitors the discharge resulting from such bypass at a frequency, at least daily, sufficient to prove compliance with the discharge limitations specified in Part I.A. of this Permit.
- c. A bypass is not prohibited and need not meet the discharge limitations specified in Part I.A. of this Permit if:
- (1) It is unavoidable to prevent loss of life, personal injury, or severe property damage;
 - (2) There are no feasible alternatives to the bypass, such as the use of auxiliary treatment facilities, retention of untreated wastes, or maintenance during normal periods of equipment downtime. This condition is not satisfied if the Permittee could have installed adequate backup equipment to prevent a bypass which occurred during normal periods of equipment downtime or preventive maintenance; and
 - (3) The Permittee submits a written request for authorization to bypass to the Director at least ten (10) days, if possible, prior to the anticipated bypass or within 24 hours of an unanticipated bypass, the Permittee is granted such authorization, and Permittee complies with any conditions imposed by the Director to minimize any adverse impact to waters resulting from the bypass.
- d. The Permittee has the burden of establishing that each of the conditions of Parts II.B.1.b. or c. have been met to qualify for an exception to the general prohibition against bypassing contained in Part II.B.1.a. and an exemption, where applicable, from the discharge limitations specified in Part I.A. of this Permit.

2. Upset

- a. The Permittee may seek to demonstrate that noncompliance with technology-based effluent limits occurred as a result of an upset if the conditions of Part II.B.2.b are met and if the Permittee complies with the conditions provided in Part II.B.2.c.
- b. If the Permittee wishes to establish the affirmative defense of an upset for technology-based effluent limit noncompliance, the Permittee must demonstrate through properly signed, contemporaneous operating logs, or other relevant evidence that:
 - (1) An upset occurred and that the Permittee can identify the specific cause(s) of the upset;
 - (2) The wastewater treatment facility was at the time being properly operated in accordance with Part II.B.d.
 - (3) The Permittee submitted notice of the noncompliance during the upset as required by Part II.B.2.c; and
 - (4) The Permittee complied with any remedial measures required under Part II.A.7. of this Permit.
- c. If the Permittee wishes to establish the affirmative defense of an upset for technology-based effluent limit noncompliance, the Permittee shall:

- (1) No later than 24-hours after becoming aware of the occurrence of the upset, orally report the occurrence and circumstances of the upset to the Director in accordance with Part I.G.2.; and
 - (2) No later than five (5) days after becoming aware of the occurrence of the upset, furnish the Director with evidence, including properly signed, contemporaneous operating logs, design drawings, construction certification, maintenance records, weir flow measurements, dated photographs, rain gauge measurements, or other relevant evidence, demonstrating that:
 - (i) An upset occurred;
 - (ii) The Permittee can identify the specific cause(s) of the upset;
 - (iii) The Permittee's treatment facility was being properly operated at the time of the upset; and
 - (iv) The Permittee promptly took all reasonable steps to minimize any adverse impact to waters resulting from the upset.
- d. A discharge which is an overflow from a treatment facility or system, or an excess discharge from a point source associated with a treatment facility or system and which results from a 24-hour precipitation event larger than a 10-year, 24-hour precipitation event is not eligible to be considered as a result of an upset unless:
- (1) The treatment facility or system is designed, constructed, and maintained to contain the maximum volume of wastewater which would be generated by the facility during a 24-hour period without an increase in volume from precipitation and the maximum volume of wastewater resulting from a 10-year, 24-hour precipitation event or to treat the maximum flow associated with these volumes. In computing the maximum volume of wastewater which would result from a 10-year, 24-hour precipitation event, the volume which would result from all areas contributing runoff to the individual treatment facility must be included (i.e., all runoff that is not diverted from the mining area and runoff which is not diverted from the preparation plant area); and
 - (2) The Permittee takes all reasonable steps to maintain treatment of the wastewater and minimize the amount of overflow or excess discharge.
- e. The Permittee has the burden of proof in defense of any enforcement action as a result of noncompliance of technology-based effluent limits the Permittee proposes to attribute to an upset.

C. PERMIT CONDITIONS AND RESTRICTIONS

1. Prohibition against Discharge from Facilities Not Certified

- a. Notwithstanding any other provisions of this Permit, if the permitted facility has not obtained or is not required to obtain a permit from the Alabama Surface Mining Commission, any discharge(s) from any point or nonpoint source(s) from the permitted facility which was not certified to the Department on a form approved by the Department by a professional engineer, registered in the State of Alabama, as being designed, constructed, and in accordance with plans and specifications reviewed by the Department is prohibited; or

- b. Notwithstanding any other provisions of this Permit, if the permitted facility has obtained or is required to obtain a permit from the Alabama Surface Mining Commission, any discharge(s) from any point or nonpoint source(s) from the permitted facility which is associated with a treatment facility which was not constructed and certified to the Alabama Surface Mining Commission pursuant to applicable provisions of said Commission's regulations, is prohibited until the Permittee submits to the Alabama Surface Mining Commission, certification by a professional engineer, registered in the State of Alabama, certifying that such facility has been constructed in accordance with plans and specifications approved by the Alabama Surface Mining Commission. This requirement shall not apply to pumped discharges from the underground works of underground coal mines where no surface structure is required by the Alabama Surface Mining Commission, provided the Department is notified in writing of the completion or installation of such facilities, and the pumped discharges will meet permit effluent limits without treatment.

2. Permit Modification, Suspension, Termination, and Revocation

- a. This Permit may be modified, suspended, terminated, or revoked and reissued, in whole or in part, during its term for cause, including but not limited to, the following:
 - (1) The violation of any term or condition of this Permit;
 - (2) The obtaining of this Permit by misrepresentation or the failure to disclose fully all relevant facts;
 - (3) The submission of materially false or inaccurate statements or information in the permit application or reports required by the Permit;
 - (4) The need for a change in any condition that requires either a temporary or permanent reduction or elimination of the permitted discharge;
 - (5) The existence of any typographical or clerical errors or of any errors in the calculation of discharge limitations;
 - (6) The existence of material and substantial alterations or additions to the facility or activity generating wastewater which occurred after permit issuance which justify the application of permit conditions that are different or absent in the existing permit;
 - (7) The threat of the Permittee's discharge on human health or welfare; or
 - (8) Any other cause allowed by ADEM Admin. Code ch. 335-6-6.
- b. The filing of a request by the Permittee for modification, suspension, termination, or revocation and reissuance of this Permit, in whole or in part, does not stay any Permit term or condition of this Permit.

3. Automatic Expiration of Permits for New or Increased Discharges

- a. Except as provided by ADEM Admin. Code r. 335-6-6-.02(h) and 335-6-6-.05, if this Permit was issued for a new discharger or new source, it shall expire eighteen months after the issuance date if construction has not begun during that eighteen month period.

- b. Except as provided by ADEM Admin. Code r. 335-6-6-.02(h) and 335-6-6-.05, if any portion of this Permit was issued or modified to authorize the discharge of increased quantities of pollutants to accommodate the modification of an existing facility, that portion of this Permit shall expire eighteen months after this Permit's issuance if construction of the modification has not begun within eighteen month period.
- c. Construction has begun when the owner or operator has:
 - (1) Begun, or caused to begin as part of a continuous on-site construction program:
 - (i) Any placement, assembly, or installation of facilities or equipment; or
 - (ii) Significant site preparation work including clearing, excavation, or removal of existing buildings, structures, or facilities which is necessary for the placement, assembly, or installation of new source facilities or equipment; or
 - (2) Entered into a binding contractual obligation for the purpose of placement, assembly, or installation of facilities or equipment which are intended to be used in its operation within a reasonable time. Options to purchase or contracts which can be terminated or modified without substantial loss, and contracts for feasibility, engineering, and design studies do not constitute a contractual obligation under the paragraph. The entering into a lease with the State of Alabama for exploration and production of hydrocarbons shall also be considered beginning construction.
- d. The automatic expiration of this Permit for new or increased discharges if construction has not begun within the eighteen month period after the issuance of this Permit may be tolled by administrative or judicial stay.

4. Transfer of Permit

This Permit may not be transferred or the name of the Permittee changed without notice to the Director and subsequent modification or revocation and reissuance of this Permit to identify the new Permittee and to incorporate any other changes as may be required under the FWPCA or AWPCA. In the case of a change in name, ownership, or control of the Permittee's premises only, a request for permit modification in a format acceptable to the Director is required at least 30 days prior to the change. In the case of a change in name, ownership, or control of the Permittee's premises accompanied by a change or proposed change in effluent characteristics, a complete permit application is required to be submitted to the Director at least 180 days prior to the change. Whenever the Director is notified of a change in name, ownership, or control, he may decide not to modify the existing Permit and require the submission of a new permit application.

5. Groundwater

Unless authorized on page 1 of this Permit, this Permit does not authorize any discharge to groundwater. Should a threat of groundwater contamination occur, the Director may require groundwater monitoring to properly assess the degree of the problem, and the Director may require that the Permittee undertake measures to abate any such discharge and/or contamination.

6. Property and Other Rights

This Permit does not convey any property rights in either real or personal property, or any exclusive privileges, nor does it authorize any injury to persons or property or invasion of other private rights, trespass, or any infringement of Federal, State, or local laws or regulations, nor does

it authorize or approve the construction of any physical structures or facilities or the undertaking of any work in any waters of the State or of the United States.

D. RESPONSIBILITIES

1. Duty to Comply

- a. The Permittee must comply with all terms and conditions of this Permit. Any permit noncompliance constitutes a violation of the AWPCA, AEMA, and the FWPCA and is grounds for enforcement action, for permit termination, revocation and reissuance, suspension, modification, or denial of a permit renewal application.
- b. The Permittee shall comply with effluent standards or prohibitions established under Section 307(a) of the FWPCA for toxic pollutants within the time provided in the regulations that establish these standards or prohibitions, even if this Permit has not yet been modified to incorporate the effluent standard, prohibition or requirement.
- c. For any violation(s) of this Permit, the Permittee is subject to a civil penalty as authorized by the AWPCA, the AEMA, the FWPCA, and Code of Alabama 1975, §§22-22A-1 et. seq., as amended, and/or a criminal penalty as authorized by Code of Alabama 1975, §22-22-1 et. seq., as amended.
- d. The necessity to halt or reduce production or other activities in order to maintain compliance with the conditions of this Permit shall not be a defense for a Permittee in an enforcement action.
- e. Nothing in this Permit shall be construed to preclude or negate the Permittee's responsibility or liability to apply for, obtain, or comply with other ADEM, federal, state, or local government permits, certifications, licenses, or other approvals.
- f. The discharge of a pollutant from a source not specifically identified in the permit application for this Permit and not specifically included in the description of an outfall in this Permit is not authorized and shall constitute noncompliance with this Permit.
- g. The Permittee shall take all reasonable steps, including cessation of production or other activities, to minimize or prevent any violation of this Permit or to minimize or prevent any adverse impact of any permit violation.

2. Change in Discharge

- a. The Permittee shall apply for a permit modification at least 180 days in advance of any facility expansion, production increase, process change, or other action that could result in the discharge of additional pollutants, increase the quantity of a discharged pollutant, or that could result in an additional discharge point. This requirement also applies to pollutants that are not subject to discharge limitations in this Permit. No new or increased discharge may begin until the Director has authorized it by issuance of a permit modification or a reissued permit.
- b. The Permittee shall notify the Director as soon as it knows or has reason to believe that it has begun or expects to begin to discharge any pollutant listed as a toxic pollutant pursuant to Section 307(a) of the FWPCA, 33 U.S.C. §1317(a), any substance designated as a hazardous substance pursuant to Section 311(b)(2) of the FWPCA, 33 U.S.C. §1321(b)(2), any waste listed as a hazardous waste pursuant to Code of Alabama 1975, §22-30-10, or any other pollutants or other wastes which is not subject to any discharge limitations specified in Part I.A. of this Permit and was not reported in the Permittee's

application, was reported in the Permittee's application in concentrations or mass rates lower than that which the Permittee expects to begin to be discharged, or has reason to believe has begun to be discharged.

3. Compliance with Toxic or Other Pollutant Effluent Standard or Prohibition

If any applicable effluent standard or prohibition (including any schedule of compliance specified in such effluent standard or prohibition) is established under Sections 301(b)(2)(C),(D),(E) and (F) of the FWPCA, 33 U.S.C. §1311(b)(2)(C),(D),(E), and (F); 304(b)(2) of the FWPCA, 33 U.S.C. §1314(b)(2); or 307(a) of the FWPCA, 33 U.S.C. §1317(a), for a toxic or other pollutant discharged by the Permittee, and such standard or prohibition is more stringent than any discharge limitation on the pollutant specified in Part I.A. of this Permit or controls a pollutant not limited in Part I.A. of this Permit, this Permit shall be modified to conform to the toxic or other pollutant effluent standard or prohibition and the Permittee shall be notified of such modification. If this Permit has not been modified to conform to the toxic or other pollutant effluent standard or prohibition before the effective date of such standard or prohibition, the authorization to discharge in this Permit shall be void to the extent that any discharge limitation on such pollutant in Part I.A. of this Permit exceeds or is inconsistent with the established toxic or other pollutant effluent standard or prohibition.

4. Compliance with Water Quality Standards and Other Provisions

- a. On the basis of the Permittee's application, plans, or other available information, the Department has determined that compliance with the terms and conditions of this Permit will assure compliance with applicable water quality standards. However, this Permit does not relieve the Permittee from compliance with applicable State water quality standards established in ADEM Admin. Code ch. 335-6-10, and does not preclude the Department from taking action as appropriate to address the potential for contravention of applicable State water quality standards which could result from discharges of pollutants from the permitted facility.
- b. Compliance with Permit terms and conditions notwithstanding, if the Permittee's discharge(s) from point source(s) identified on Page 1 of this Permit cause(s) or contribute(s) to a condition in contravention of State water quality standards, the Department may require abatement action to be taken by the Permittee, modify the Permit pursuant to the Department's rules and regulations, or both.
- c. If the Department determines, on the basis of a notice provided pursuant to Part II.C.2. of this Permit or any investigation, inspection, or sampling, that a modification of this Permit is necessary to assure maintenance of water quality standards or compliance with other provisions of the AWPCA or FWPCA, the Department may require such modification and, in cases of emergency, the Director may prohibit the noticed act until the Permit has been modified.

5. Compliance with Statutes and Rules

- a. This Permit has been issued under ADEM Admin. Code div. 335-6. All provisions of this division, that are applicable to this Permit, are hereby made a part of this Permit. A copy of this division may be obtained for a small charge from the Office of General Counsel, Alabama Department of Environmental Management, 1400 Coliseum Blvd., Montgomery, AL 36110-2059.
- b. This Permit does not authorize the noncompliance with or violation of any Laws of the State of Alabama or the United States of America or any regulations or rules implementing such laws. FWPCA, 33 U.S.C. Section 1319, and Code of Alabama 1975, Section 22-22-14.

6. Right of Entry and Inspection

The Permittee shall allow the Director, or an authorized representative, upon the presentation of credentials and other documents as may be required by law to:

- a. Enter upon the Permittee's premises where a regulated facility or activity is located or conducted, or where records must be kept under the conditions of the Permit;
- b. Have access to and copy, at reasonable times, any records that must be kept under the conditions of this Permit;
- c. Inspect at reasonable times any facilities, equipment (including monitoring and control equipment), practices, or operations regulated or required under this Permit; and
- d. Sample or monitor at reasonable times, for the purposes of assuring Permit compliance or as otherwise authorized by the AWPCA, any substances or parameters at any location.

7. Duty to Reapply or Notify of Intent to Cease Discharge

- a. If the Permittee intends to continue to discharge beyond the expiration date of this Permit, the Permittee shall file with the Department a complete permit application for reissuance of this Permit at least 180 days prior to its expiration.
- b. If the Permittee does not desire to continue the discharge(s) allowed by this Permit, the Permittee shall notify the Department at least 180 days prior to expiration of this Permit of the Permittee's intention not to request reissuance of this Permit. This notification must include the information required in Part I.D.4.a. and be signed by an individual meeting the signatory requirements for a permit application as set forth in ADEM Admin. Code r. 335-6-6-.09.
- c. Failure of the Permittee to submit to the Department a complete application for reissuance of this Permit at least 180 days prior to the expiration date of this Permit will void the automatic continuation of this Permit provided by ADEM Admin. Code r. 335-6-6-.06; and should this Permit not be reissued for any reason, any discharge after the expiration of this Permit will be an unpermitted discharge.

PART III ADDITIONAL REQUIREMENTS, CONDITIONS, AND LIMITATIONS

A. CIVIL AND CRIMINAL LIABILITY

1. Tampering

Any person who falsifies, tampers with, or knowingly renders inaccurate any monitoring device or method required to be maintained or performed under this Permit shall, upon conviction, be subject to penalties and/or imprisonment as provided by the AWPCA and/or the AEMA.

2. False Statements

Any person who knowingly makes any false statement, representation, or certification in any record or other document submitted or required to be maintained under this Permit, including monitoring reports or reports of compliance or noncompliance shall, upon conviction, be punished as provided by applicable State and Federal law.

3. Permit Enforcement

This NPDES Permit is a Permit for the purpose of the AWPCA, the AEMA, and the FWPCA, and as such all terms, conditions, or limitations of this Permit are enforceable under State and Federal law.

4. Relief From Liability

Except as provided in Part II.B.1. (Bypass) and Part II.B.2. (Upset), nothing in this Permit shall be construed to relieve the Permittee of civil or criminal liability under the AWPCA, AEMA, or FWPCA for noncompliance with any term or condition of this Permit.

B. OIL AND HAZARDOUS SUBSTANCE LIABILITY

Nothing in this Permit shall be construed to preclude the institution of any legal action or relieve the Permittee from any responsibilities, liabilities, or penalties to which the Permittee is or may be subject to under Section 311 of the FWPCA, 33 U.S.C. §1321.

C. AVAILABILITY OF REPORTS

Except for data determined to be confidential under Code of Alabama 1975, §22-22-9(c), all reports prepared in accordance with the terms of this Permit shall be available for public inspection at the offices of the Department. Effluent data shall not be considered confidential. Knowingly making any false statement in any such report may result in the imposition of criminal penalties as provided for in Section 309 of the FWPCA, 33 U.S.C. §1319, and Code of Alabama 1975, §22-22-14.

D. DEFINITIONS

1. Alabama Environmental Management Act (AEMA) - means Code of Alabama 1975, §§22-22A-1 et. seq., as amended.
2. Alabama Water Pollution Control Act (AWPCA) - means Code of Alabama 1975, §§22-22-1 et. seq., as amended.
3. Average monthly discharge limitation - means the highest allowable average of "daily discharges" over a calendar month, calculated as the sum of all "daily discharges" measured during a calendar

month divided by the number of "daily discharges" measured during that month (zero discharge days shall not be included in the number of "daily discharges" measured and a less than detectable test result shall be treated as a concentration of zero if the most sensitive EPA approved method was used).

4. Arithmetic Mean - means the summation of the individual values of any set of values divided by the number of individual values.
5. BOD - means the five-day measure of the pollutant parameter biochemical oxygen demand
6. Bypass - means the intentional diversion of waste streams from any portion of a treatment facility.
7. CBOD - means the five-day measure of the pollutant parameter carbonaceous biochemical oxygen demand.
8. Controlled Surface Mine Drainage – means any surface mine drainage that is pumped or siphoned from the active mining area.
9. Crushed stone mine - means an area on or beneath land which is mined, quarried, or otherwise disturbed in activity related to the extraction, removal, or recovery of stone from natural or artificial deposits, including active mining, reclamation, and mineral storage areas, for production of crushed stone.
10. Daily discharge - means the discharge of a pollutant measured during any consecutive 24-hour period in accordance with the sample type and analytical methodology specified by the discharge permit.
11. Daily maximum - means the highest value of any individual sample result obtained during a day.
12. Daily minimum - means the lowest value of any individual sample result obtained during a day.
13. Day - means any consecutive 24-hour period.
14. Department - means the Alabama Department of Environmental Management.
15. Director - means the Director of the Department or his authorized representative or designee.
16. Discharge - means "[t]he addition, introduction, leaking, spilling or emitting of any sewage, industrial waste, pollutant or other waste into waters of the state." Code of Alabama 1975, §22-22-1(b)(8).
17. Discharge monitoring report (DMR) - means the form approved by the Director to accomplish monitoring report requirements of an NPDES Permit.
18. DO - means dissolved oxygen.
19. E. coli – means the pollutant parameter *Escherichia coli*.
20. 8HC - means 8-hour composite sample, including any of the following:
 - a. The mixing of at least 5 equal volume samples collected at constant time intervals of not more than 2 hours over a period of not less than 8 hours between the hours of 6:00 a.m. and 6:00 p.m. If the sampling period exceeds 8 hours, sampling may be conducted beyond the 6:00 a.m. to 6:00 p.m. period.

- b. A sample continuously collected at a constant rate over period of not less than 8 hours between the hours of 6:00 a.m. and 6:00 p.m. If the sampling period exceeds 8 hours, sampling may be conducted beyond the 6:00 a.m. to 6:00 p.m. period.
21. EPA - means the United States Environmental Protection Agency.
22. Federal Water Pollution Control Act (FWPCA) - means 33 U.S.C. §§1251 et. seq., as amended.
23. Flow – means the total volume of discharge in a 24-hour period.
24. Geometric Mean - means the Nth root of the product of the individual values of any set of values where N is equal to the number of individual values. The geometric mean is equivalent to the antilog of the arithmetic mean of the logarithms of the individual values. For purposes of calculating the geometric mean, values of zero (0) shall be considered one (1).
25. Grab Sample - means a single influent or effluent portion which is not a composite sample. The sample(s) shall be collected at the period(s) most representative of the discharge.
26. Indirect Discharger - means a nondomestic discharger who discharges pollutants to a publicly owned treatment works or a privately owned treatment facility operated by another person.
27. Industrial User - means those industries identified in the Standard Industrial Classification manual, Bureau of the Budget 1967, as amended and supplemented, under the category “Division D – Manufacturing” and such other classes of significant waste producers as, by regulation, the Director deems appropriate.
28. mg/L - means milligrams per liter of discharge.
29. MGD - means million gallons per day.
30. Monthly Average - means, other than for E. coli bacteria, the arithmetic mean of all the composite or grab samples taken for the daily discharges collected in one month period. The monthly average for E. coli bacteria is the geometric mean of daily discharge samples collected in a one month period. The monthly average for flow is the arithmetic mean of all flow measurements taken in a one month period. (Zero discharges shall not be included in the calculation of monthly averages.)
31. New Discharger - means a person owning or operating any building, structure, facility or installation:
- a. From which there is or may be a discharge of pollutants;
 - b. From which the discharge of pollutants did not commence prior to August 13, 1979, and which is not a new source; and
 - c. Which has never received a final effective NPDES Permit for dischargers at that site.
32. New Source - means:
- a. A new source as defined for coal mines by 40 CFR Part 434.11 (1994); and
 - b. Any building, structure, facility, or installation from which there is or may be a discharge of pollutants, the construction of which commenced:
 - (1) After promulgation of standards of performance under Section 306 of FWPCA which are applicable to such source; or

- (2) After proposal of standards of performance in accordance with Section 306 of the FWPCA which are applicable to such source, but only if the standards are promulgated in accordance with Section 206 within 120 days of their proposal.
33. NH₃-N - means the pollutant parameter ammonia, measured as nitrogen.
34. 1-year, 24-hour precipitation event - means the maximum 24-hour precipitation event with a probable recurrence interval of once in one year as defined by the National Weather Service and Technical Paper No. 40, "Rainfall Frequency Atlas of the U.S.," May 1961, or equivalent regional or rainfall probability information developed therefrom.
35. Permit application - means forms and additional information that are required by ADEM Admin. Code r. 335-6-6-.08 and applicable permit fees.
36. Point Source - means "any discernible, confined and discrete conveyance, including but not limited to any pipe, channel, ditch, tunnel, conduit, well, discrete fissure, container, rolling stock, concentrated animal feeding operation, or vessel or other floating craft from which pollutants are or may be discharged." Section 502(14) of the FWPCA, 33 U.S.C. §1362(14).
37. Pollutant - includes for purposes of this Permit, but is not limited to, those pollutants specified in Code of Alabama 1975, §22-22-1(b)(3) and those effluent characteristics, excluding flow, specified in Part I.A. of this Permit.
38. Pollutant of Concern - means those pollutants for which a water body is listed as impaired or which contribute to the listed impairment.
39. Pollution Abatement and/or Prevention Plan (PAP Plan) – mining operations plan developed to minimize impacts on water quality to avoid a contravention of the applicable water quality standards as defined in ADEM Admin. Code r. 335-6-9-.03
40. Preparation, Dry - means a dry preparation facility within which the mineral/material is cleaned, separated, or otherwise processed without use of water or chemical additives before it is shipped to the customer or otherwise utilized. A dry preparation plant includes all ancillary operations and structures necessary to clean, separate, or otherwise process the mineral/material, such as storage areas and loading facilities. Dry preparation also includes minor water spray(s) used solely for dust suppression on equipment and roads to minimize dust emissions.
41. Preparation, Wet - means a wet preparation facility within which the mineral/material is cleaned, separated, or otherwise processed using water or chemical additives before it is shipped to the customer or otherwise utilized. A wet preparation plant includes all ancillary operations and structures necessary to clean, separate, or otherwise process the mineral/material, such as storage areas and loading facilities. Wet preparation also includes mineral extraction/processing by dredging, slurry pumping, etc.
42. Privately Owned Treatment Works - means any devices or system which is used to treat wastes from any facility whose operator is not the operator of the treatment works, and which is not a "POTW".
43. Publicly Owned Treatment Works (POTW) - means a wastewater collection and treatment facility owned by the State, municipality, regional entity composed of two or more municipalities, or another entity created by the State or local authority for the purpose of collecting and treating municipal wastewater.
44. Receiving Stream - means the "waters" receiving a "discharge" from a "point source".

45. Severe property damage - means substantial physical damage to property, damage to the treatment facilities which causes them to become inoperable, or substantial and permanent loss of natural resources which can reasonably be expected to occur in the absence of a bypass. Severe property damage does not mean economic loss caused by delays in production.
46. 10-year, 24-hour precipitation event - means that amount of precipitation which occurs during the maximum 24-hour precipitation event with a probable recurrence interval of once in ten years as defined by the National Weather Service and Technical Paper No. 40, "Rainfall Frequency Atlas of the U.S.," May 1961, or equivalent regional or rainfall probability information developed therefrom.
47. TKN - means the pollutant parameter Total Kjeldahl Nitrogen.
48. TON - means the pollutant parameter Total Organic Nitrogen.
49. TRC - means Total Residual Chlorine.
50. TSS – means the pollutant parameter Total Suspended Solids
51. Treatment facility and treatment system - means all structures which contain, convey, and as necessary, chemically or physically treat mine and/or associated preparation plant drainage, which remove pollutants limited by this Permit from such drainage or wastewater. This includes all pipes, channels, ponds, tanks, and all other equipment serving such structures.
52. 24HC - means 24-hour composite sample, including any of the following:
 - a. The mixing of at least 12 equal volume samples collected at constant time intervals of not more than 2 hours over a period of 24 hours;
 - b. A sample collected over a consecutive 24-hour period using an automatic sampler composite to one sample. As a minimum, samples shall be collected hourly and each shall be no more than one twenty-fourth (1/24) of the total sample volume collected; or
 - c. A sample collected over a consecutive 24-hour period using an automatic composite sampler composited proportional to flow.
53. 24-hour precipitation event - means that amount of precipitation which occurs within any 24-hour period.
54. 2-year, 24-hour precipitation event - means the maximum 24-hour precipitation event with a probable recurrence interval of once in two years as defined by the National Weather Service and Technical Paper No. 40, "Rainfall Frequency Atlas of the U.S.," May 1961, or equivalent regional or rainfall probability information developed therefrom.
55. Upset - means an exceptional incident in which there is an unintentional and temporary noncompliance with technology-based permit discharge limitations because of factors beyond the control of the Permittee. An upset does not include noncompliance to the extent caused by operational error, improperly designed treatment facilities, inadequate facilities, lack of preventive maintenance, or careless or improper operation.
56. Waters - means "[a]ll waters of any river, stream, watercourse, pond, lake, coastal, ground or surface water, wholly or partially within the State, natural or artificial. This does not include waters which are entirely confined and retained completely upon the property of a single individual, partnership, or corporation unless such waters are used in interstate commerce." Code of Alabama 1975, §22-22-1(b)(2). "Waters" include all "navigable waters" as defined in §502(7) of the FWPCA, 33 U.S.C. §1362(7), which are within the State of Alabama.

57. Week - means the period beginning at twelve midnight Saturday and ending at twelve midnight the following Saturday.
58. Weekly (7-day and calendar week) Average – is the arithmetic mean of all samples collected during a consecutive 7-day period or calendar week, whichever is applicable. The calendar week is defined as beginning on Sunday and ending on Saturday. Weekly averages shall be calculated for all calendar weeks with Saturdays in the month. If a calendar week overlaps two months (i.e., the Sunday is in one month and the Saturday in the following month), the weekly average calculated for the calendar week shall be included in the data for the month that contains the Saturday.

E. SEVERABILITY

The provisions of this Permit are severable, and if any provision of this Permit or the application of any provision of this Permit to any circumstance, is held invalid, the application of such provision to other circumstances, and the remainder of this Permit, shall not be affected thereby.

F. PROHIBITIONS AND ACTIVITIES NOT AUTHORIZED

1. Discharges from disposal or landfill activities as described in ADEM Admin. Code div. 335-13 are not authorized by this Permit unless specifically approved by the Department.
2. Relocation, diversion, or other alteration of a water of the State is not authorized by this Permit unless specifically approved by the Department.
3. Lime or cement manufacturing or production and discharge of process waters from such manufacturing or production is not authorized by this Permit unless specifically approved by the Department.
4. Concrete or asphalt manufacturing or production and discharge of process waters from such manufacturing or production is not authorized by this Permit unless specifically approved by the Department.
5. The discharge of wastewater, generated by any process, facility, or by any other means not under the operational control of the Permittee or not identified in the application for this Permit or not identified specifically in the description of an outfall in this Permit is not authorized by this Permit.

G. DISCHARGES TO IMPAIRED WATERS

1. This Permit does not authorize new sources or new discharges of pollutants of concern to impaired waters unless consistent with an EPA-approved or EPA-established Total Maximum Daily Load (TMDL) and applicable State law, or unless compliance with the limitations and requirements of the Permit ensure that the discharge will not contribute to further degradation of the receiving stream. Impaired waters are those that do not meet applicable water quality standards and are identified on the State of Alabama's §303(d) list or on an EPA-approved or EPA-established TMDL. Pollutants of concern are those pollutants for which the receiving water is listed as impaired or contribute to the listed impairment.
2. Facilities that discharge into a receiving stream which is listed on the State of Alabama's §303(d) list of impaired waters, and with discharges that contain the pollutant(s) for which the waters are impaired, must within six (6) months of the Final §303(d) list approval, document in its BMP plan how the BMPs will control the discharge of the pollutant(s) of concern, and must ensure that there

will be no increase of the pollutants of concern. A monitoring plan to assess the effectiveness of the BMPs in achieving the allocations must also be included in the BMP plan.

3. If the facility discharges to impaired waters as described above, it must determine whether a TMDL has been developed and approved or established by EPA for the listed waters. If a TMDL is approved or established during this Permit cycle by EPA for any waters into which the facility discharges, the facility must review the applicable TMDL to see if it includes requirements for control of any water discharged by the Permittee. Within six (6) months of the date of TMDL approval or establishment, the facility must notify the Department on how it will modify its BMP plan to include best management practices specifically targeted to achieve the allocations prescribed by the TMDL, if necessary. Any revised BMP plans must be submitted to the Department for review. The facility must include in the BMP plan a monitoring component to assess the effectiveness of the BMPs in achieving the allocations.

**ALABAMA DEPARTMENT OF ENVIRONMENTAL MANAGEMENT
WATER DIVISION**

NPDES INDIVIDUAL PERMIT RATIONALE

Company Name: Davis Materials, Inc.
Facility Name: Vance Pit
County: Tuscaloosa
Permit Number: AL0083917
Prepared by: Jasmine White
Date: February 22, 2022
Receiving Waters: Banks Creek, Unnamed Tributary to Banks Creek
Permit Coverage: Crushed Limestone, Dry and Wet Preparations, Transportation, Storage, and Associated Areas
SIC Code: 1429

The Department has made a tentative determination that the available information is adequate to support modification and issuance of this permit. The modification addresses the addition of Outfall 003-1.

This proposed permit covers a crushed limestone mine, dry and wet preparations, transportation, storage, and associated areas, which discharge to surface waters of the state. Other crushed rock is also present in a small quantity.

The proposed permit authorizes treated discharges into an unnamed tributary to Banks Creek classified as Fish and Wildlife (F&W) per ADEM Admin. Code ch. 335-6-11. If the requirements of the proposed permit are fully implemented, the facility will not discharge pollutants at levels that will cause or contribute to a violation of the F&W classification.

Full compliance with the proposed permit terms and conditions is expected to be protective of instream water quality and ensure consistency with applicable instream State water quality standards (WQS) for the receiving stream.

Technology Based Effluent Limits (TBELs) for crushed stone mining facilities can be found in 40 CFR 436.22(1) and (2) for facilities that recycle waste water for use in processing and mine dewatering, respectively. The TBELs were promulgated for existing dischargers using the Best Practicable Control Technology Available (BPT). New Source Performance Standards (NSPS) have not yet been developed by the EPA for the Crushed Stone Subcategory.

The instream WQS for pH, for streams classified as F&W, are 6.0 - 8.5 s.u per ADEM Admin Code r. 335-6-10-.09. Information provided in the Permittee's application indicated that Outfall 003-1 could discharge chronically when the discharge/stream flow ratio may be high; therefore, discharge limitations for pH of 6.0 – 8.5 s.u. are proposed for Outfall 003-1 per ADEM Admin Code r. 335-6-10-.09.

The TBELs for 40 CFR 436 Subpart B do not include limitations for Total Suspended Solids (TSS). TSS is classified as a conventional pollutant in 40 CFR 401.16 and is expected to be discharged from this type of facility. Therefore, monthly average and daily maximum effluent limitations for TSS are those proposed by the EPA for crushed stone mine drainage in the *Development Document for Effluent Limitations Guidelines and New Source Performance Standards for the Mineral Mining and Processing Point Source Category* (July 1979).

The applicant has requested, in accordance with 40 CFR Part 122.21 and their NPDES permit application, a waiver from testing for the Part A, B, and C pollutants listed in the EPA Form 2C and 2D that are not addressed in their

application. They have also certified that due to the processes involved in their mining activity these pollutants are believed to be not present in the waste stream.

The Pollution Abatement/Prevention (PAP) plan for this facility has been prepared by a professional engineer (PE) registered in the State of Alabama and is designed to ensure reduction of pollutants in the waste stream to a level that, if operated properly, the discharge will not contribute to or cause a violation of applicable State WQS. The proposed permit terms and conditions are predicated on the basis of ensuring a reduction of pollutants in the discharge to a level that reduces the potential of contributing to or causing a violation of applicable State WQS.

In accordance with ADEM Admin. Code r. 335-6-3-.07 the design PE, as evidenced by their seal and/or signature on the application, has accepted full responsibility for the effectiveness of the waste treatment facility to treat the Permittee's effluent to meet NPDES permit limitations and requirements, and to fully comply with Alabama's WQS, when such treatment facilities are properly operated.

If there is a reasonable potential that a pollutant present in the treated discharges from a facility could cause or contribute to a contravention of applicable State WQS above numeric or narrative criteria, 40 CFR Part 122 requires the Department to establish effluent limits using calculated water quality criterion, establish effluent limits on a case-by-case basis using criteria established by EPA, or establish effluent limits based on an indicator parameter. Based on available information, potential pollutants discharged from this facility, if discharged within the concentrations allowed by this permit, would not have a reasonable potential to cause or contribute to a contravention of applicable State WQS.

Pursuant to ADEM Admin. Code r. 335-6-6-.12(r) this permit requires the Permittee to design and implement a Spill Prevention Control and Countermeasures (SPCC) plan for all stored chemicals, fuels and/or stored pollutants that have the potential to discharge to a water of the State. This plan must meet the minimum engineering requirements as defined in 40 CFR Part 112 and must provide for secondary containment adequate to control a potential spill.

The applicant is not proposing discharges of pollutants to a water of the State with an approved Total Maximum Daily Load (TMDL).

The applicant is not proposing discharges into a stream segment or other State water that is included on Alabama's current CWA §303(d) list.

The applicant is not proposing new discharges of pollutant(s) to an ADEM identified Tier I water.

The proposed permit action authorizes new discharges of pollutants to receiving waters determined by the Department to be waters where the quality exceeds levels necessary to support propagation of fish, shellfish, and wildlife and recreation in and on the water (Tier II). Pursuant to ADEM Admin. Code r. 335-6-10 (Antidegradation Policy and Implementation of the Antidegradation Policy), the applicant has submitted and the Department has reviewed and considered information regarding (1) demonstration of necessity/importance, (2) alternatives analysis, and (3) calculations of total annualized costs for technically feasible treatment alternatives regarding the proposed new discharges to Tier II waters. The Department has determined, based on the applicant's demonstration, that the proposed new discharges to the Tier II waters are necessary for important economic or social development in the area in which the waters are located.

ALABAMA DEPARTMENT OF ENVIRONMENTAL MANAGEMENT
WATER DIVISION

ANTIDEGRADATION RATIONALE

Company Name: Davis Materials, Inc.
Facility Name: Vance Pit
County: Tuscaloosa
Permit Number: AL0083917
Prepared by: Jasmine White
Date: March 2, 2022
Receiving Waters: Banks Creek
Stream Category: Tier II as defined by ADEM Admin. Code 335-6-10-.12

Discharge Description: This proposed permit covers a limestone and dolomite mine, dry and wet preparation plant, transportation and storage, and associated areas which discharge to surface waters.

The following preliminary determination was prepared in accordance with ADEM Admin. Code 335-6-10-.12(7)(c):

The Department has reviewed the information submitted by applicant in accordance with ADEM Admin. Code 335-6-10-.12(9). The applicant has demonstrated that there are no technically or economically viable treatment options in its alternatives analysis that would completely eliminate a direct discharge.

The permit applicant has indicated that the following economic and social benefits will result from this project:

1. The Permittee submits that the new/increased discharges will increase employment by 5 employees.
2. The Permittee estimates a total of \$50,600 will be paid in various state and local taxes.
3. The Permittee states public service will be provided to the community by providing environmental protection for Banks Creek by preventing pollution and preserving the current water use classification.
4. The Permittee submits it will provide economic and social benefits to the community by providing employment of people from Tuscaloosa and the surrounding communities. The Permittee states the material provided for construction projects could result in improved infrastructure that will be a critical part of economic growth within the region.

The Department has determined that the discharge proposed by the permit applicant is necessary for important economic and social development in the area of the outfall location in the receiving water.

Reviewed By: Eric Reidy 

Date: 03/21/22



Mining NPDES
Permit Modification Application
For Vance Pit



Prepared for
Davis Materials, Inc.
1608 17th St.
Tuscaloosa, AL 35401



Engineer's Certification

I certify that this report was prepared by me and that I am a Professional Engineer in the State of Alabama.



R. A. Deerman, PE 16938

November 01, 2021

Date

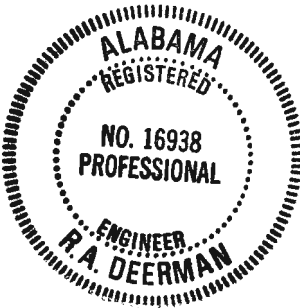

Table of Contents

1.	Introduction	5
1.1.	Location	5
1.2.	Work Description.....	5
1.3.	Contents.....	5
1.4.	Purpose	5
2.	Site Description	8
2.1.	Geologic Setting.....	8
2.2.	Soil Types	8
2.3.	Rainfall.....	8
2.4.	Streams and Wetlands.....	8
2.5.	Outfall 001 (DSN001E)	8
2.6.	Outfall 002 (DSN002E)	9
2.7.	Outfall 003 (DSN003P)	9
3.	Sedimentation Controls.....	10
3.1.	Introduction	10
3.2.	Diversions	10
3.3.	Sedimentation Ponds.....	10
4.	Pollution Abatement and Prevention Plan.....	14
4.1.	Introduction	14
4.2.	Name and Address	14
4.3.	General Information	14
4.4.	Topographic Map	14
4.5.	Diversions	14
4.6.	Operations	15
4.7.	Waste Characteristics	15
4.8.	Waste Treatment Facilities.....	17
4.9.	Haul Road Sediment Control	17
4.10.	Stream Impact Minimization.....	17
4.11.	Non-Point Impact Minimization	18
4.12.	Construction Certification	18
4.13.	Watershed Classification	18
4.14.	Facility Closure Plan	18
5.	Best Management Practices Plan	19
5.1.	Introduction	19
5.2.	Excerpts.....	19
5.3.	Preservation of Vegetation.....	20
5.4.	Dust Control.....	30
5.5.	Mulching.....	33
5.6.	Permanent Seeding	38
5.7.	Sediment Trap	47

5.8.	Sediment Barrier	50
5.9.	Stormwater Detention Basin	58
5.10.	Sediment Basin.....	66
5.11.	Outlet Protection	83
6.	Spill Prevention Control and Countermeasures Plan	94
6.1.	General Applicability	94
6.2.	No Potential for Substantial Harm.....	94
6.3.	Purpose	94
6.4.	Facility Owner, Address, and Telephone	96
6.5.	Facility Operations	96
6.6.	Petroleum Storage	96
6.7.	Petroleum Transfer Procedures	96
6.8.	Discharge Prevention Measures	97
6.9.	Discharge Discovery, Response and Cleanup.....	97
6.10.	Disposal of Recovered Materials	98
6.11.	Emergency Contact List.....	98
6.12.	Discharge Reporting Information	98
6.13.	Discharge Reporting Deadlines	99
6.14.	Personnel Training.....	99
6.15.	Security	100
7.	Drawings	101
8.	Forms.....	105
8.1.	Introduction	105

1. Introduction

1.1. Location

Davis Materials, Inc. operates the Vance Pit mine in Tuscaloosa County, west of Woodstock. Driving directions to the pit begin at the intersection of US-11 and AL-5 in Woodstock. Travel south on US-11 for 1.6 miles to Story Road and turn right. The pit is less than one mile from US-11. The property is located in Sections 17 and 20 of Township 21S and Range 6W. Figure 1-1 is a location map of the pit. Figure 1-2 is an enlarged site map on aerial photography.

1.2. Work Description

The Vance Pit of Davis Materials, Inc. produces crushed stone aggregate for commercial use.

1.3. Contents

This document contains an engineering certification, sedimentation control plans, a Pollution Abatement and Prevention (PAP) Plan, a Best Management Practices Plan, and a Spill Prevention Control and Countermeasures (SPCC) Plan.

1.4. Purpose

The purpose of this document is to modify an existing NPDES Individual Mining Permit for Davis Materials, Inc. The permit authorizes discharges from mine de-watering activities and stormwater. The permit includes two outfalls (Outfalls DSN001E and DSN002E) to Banks Creek.

The proposed modification will increase the size of the permitted area¹ and add an outfall, DSN003P. The modification will provide more area for the placement of overburden.

¹ Previously, ADEM Form 315 showed 316 acres. That is actually the total area of the parcels. The permitted area was much less. The revised ADEM Form 315 associated with this modification correctly shows 137 acres.

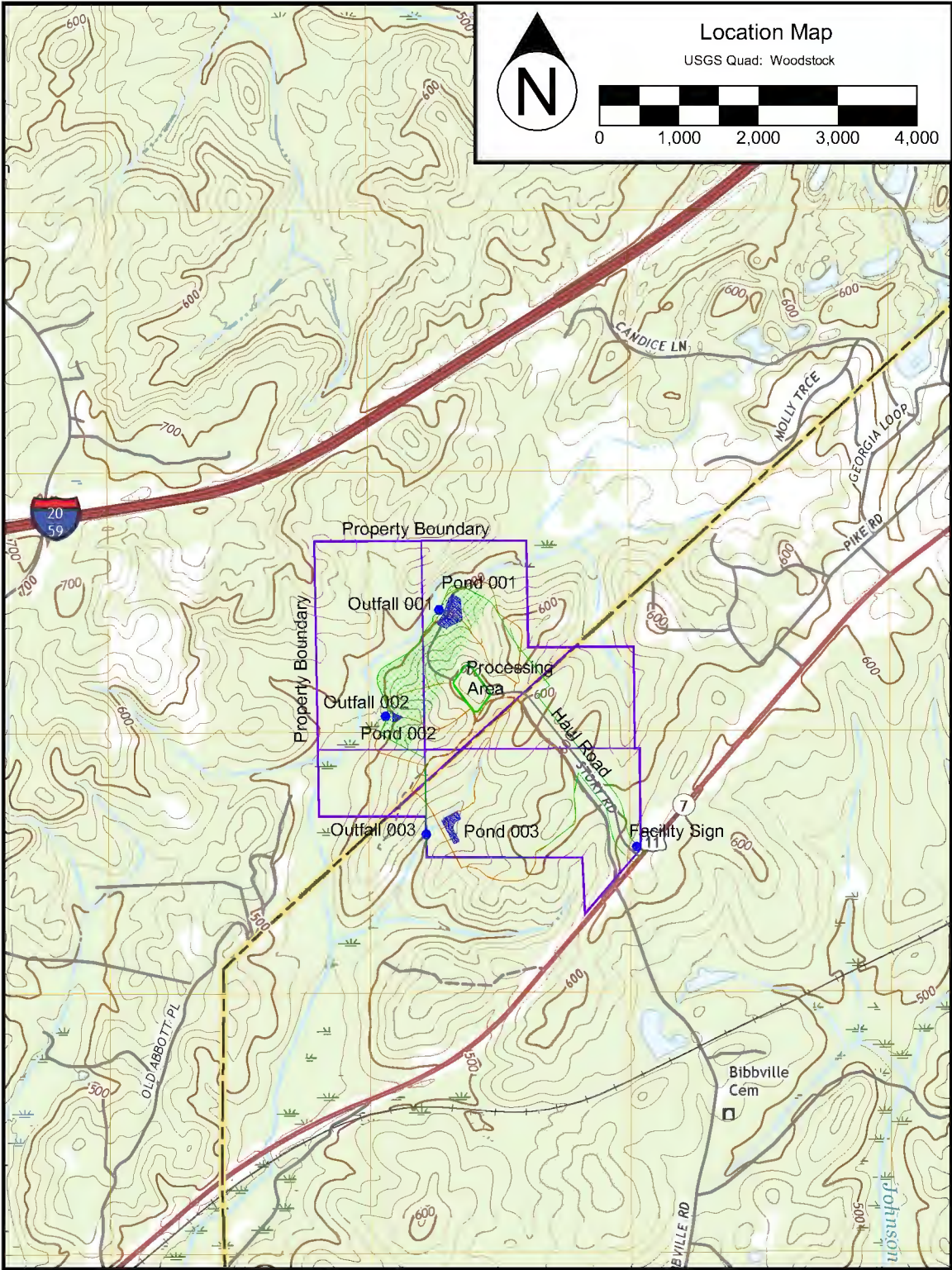

Figure 1-1. Location Map.



Figure 1-2. Site Map.

2. Site Description

2.1. Geologic Setting

The mine site is near the border of three physiographic provinces, but is probably best described as being in the western part of the Valley and Ridge physiographic province. Primarily, the mine will recover the limestone² of the Consauga Formation but there is a potential for the mining of other aggregates from the same pit.

2.2. Soil Types

The soil at the mine site consists primarily of Smithdale-Luverne complex and the Bodine-Allen association. Each of the soils is typically loamy (fine sandy loam, loam, or gravelly silt loam). The parent material consists of alluvium, colluvium, residuum derived from sandstone and shale (Allen); residuum weathered from cherty limestone (Bodine); loamy marine deposits derived from sedimentary rock (Luverne); or loamy fluviomarine deposits derived from sedimentary rock (Smithdale). Each of the soils is well drained, although Bodine is somewhat excessively drained. The erosion factors (K, in the universal soil loss equation) range from 0.15 to 0.37, indicating low to moderately high erodibility.

2.3. Rainfall

The average rainfall is approximately 54 inches per year in eastern Tuscaloosa County and northern Bibb County. The rainfall depths of design storm events are from NOAA Atlas 14. At the mine site, the 1-yr/24-hr rainfall depth is 3.66 inches, the 2-yr/24-hr rainfall depth is 4.14 inches, and the 25-yr/24-hr rainfall depth is 7.31 inches.

2.4. Streams and Wetlands

Banks Creek flows from northeast to southwest through much of the property and near the proposed mining area. No mining is proposed within 50 feet of the creek and no changes to the stream are proposed. Wetlands may exist near the creek in the floodplain, but not in the immediate vicinity of the mining area. No wetlands will be impacted by mining.

2.5. Outfall 001 (DSN001E)

Outfall DSN001E includes discharges from mine de-watering activities and stormwater. Davis Materials, Inc. may also conduct mineral dry and wet processing (crushing, screening, and washing) within the watershed. The outfall is located west from Pond 001 and discharges to Banks Creek. The geographic coordinates of the outfall are 33.2090°N and 87.1902°W. The total watershed area for DSN001E is 37 acres. The disturbed area is 9 acres.

² Throughout this document, consistent with SIC and NAICS codes, limestone includes dolomite.

2.6. Outfall 002 (DSN002E)

Outfall DSN002E includes discharges from the construction of the processing area. Pond 002 discharges to Outfall 002, located near the southern end of the mining area. Outfall 002 discharges to Banks Creek. The geographic coordinates of the outfall are 33.2053°N and 87.1924°W. The total watershed area for DSN002E is 21 acres.

2.7. Outfall 003 (DSN003P)

Proposed Outfall DSN003P will include discharges from stormwater. The initial evaluation of the site, based on borings, indicated that it might be possible to limit the size of the permitted area to the extent originally permitted. As mining activities progressed, it became obvious that the volume of overburden is greater than expected. Additional area, located within the same parcels already presented in the previous permitting process, will be used for overburden placement. Runoff from the site will drain to Pond 003. The pond will discharge to the proposed outfall on an unnamed tributary of Banks Creek. The geographic coordinates of the outfall are 33.2012°N and 87.1908°W. The total watershed area for DSN003P will be 68 acres. The maximum disturbed area will be 63 acres.

3. Sedimentation Controls

3.1. Introduction

The pollution abatement facilities are designed and constructed to control the quality of discharges from mine de-watering activities and stormwater at Outfalls DSN001E and DSN002E. The pollution abatement facilities are designed and will be constructed to control the quality of discharges from mine de-watering activities and stormwater at Outfall DSN003P. Normal drainage patterns will direct the discharges to the outfall.

3.2. Diversions

No diversions exist and none are proposed.

3.3. Sedimentation Ponds

Ponds 001 and 002 exist as designed, constructed, and certified structures. Pond 001 is at Outfall DSN001E and Pond 002 is at Outfall DSN002E. Figure 3-1 summarizes the shape and volume Pond 001 while Figure 3-2 summarizes the shape and volume of Pond 002.

Pond 003 is proposed at Outfall DSN003P. For design, the watershed comprises hydrologic soil groups B and C with large areas of bare earth such that the average curve number is 84. The pond volume at the normal pool level is 15.9 ac-ft, greater than the required sediment volume of 15.7 ac-ft (0.25 acre-feet per acre for 63 acres is 15.7 acre-feet). The upstream toe of the Pond 003 embankment is no lower than an elevation of 506.00. The elevation difference from the upstream toe of the embankment to the crest of the open channel spillway is 13.00 feet. The volume of water impounded by the embankment from the upstream toe of the embankment to the crest of the open channel spillway is 19.2 acre-feet. Additional volume (water contained in the excavated area below elevation 206.00) brings the total pond volume to 22.2 acre-feet at the crest of the open channel spillway.

Key items from the analysis of Pond 003 using HEC-HMS include the following:

- Normal Pool Elevation: 516.00
- 1-yr/24-hr Peak Elevation: 517.95
- Crest of Emergency Spillway: 519.00
- 25-yr/24-hr Peak Elevation: 520.50
- Top of Dam: 523.00

Figure 3-3 summarizes the shape and volume Pond 003. Construction plans are also included in this application.

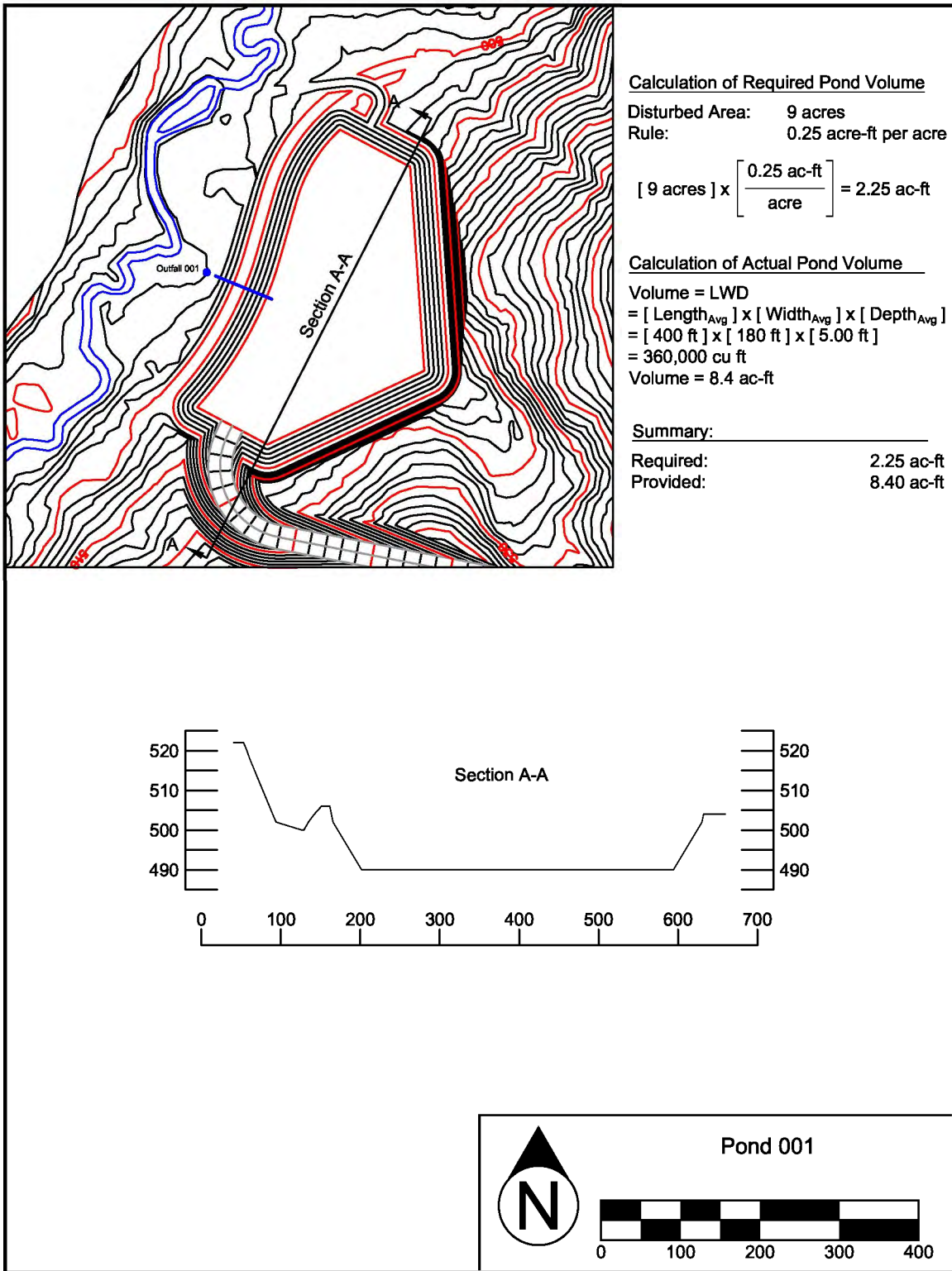

Figure 3-1. Pond 001.

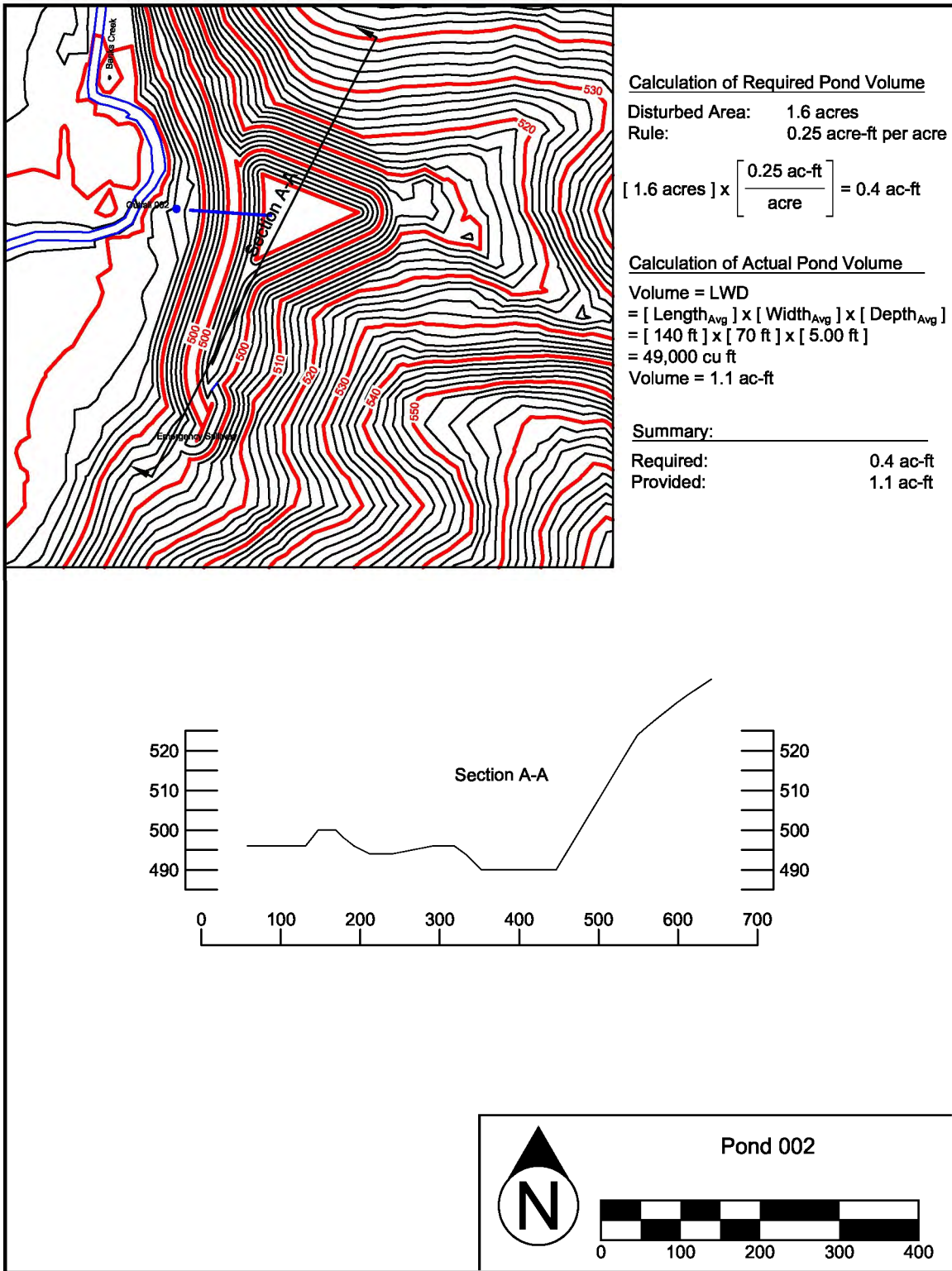

Figure 3-2. Pond 002.

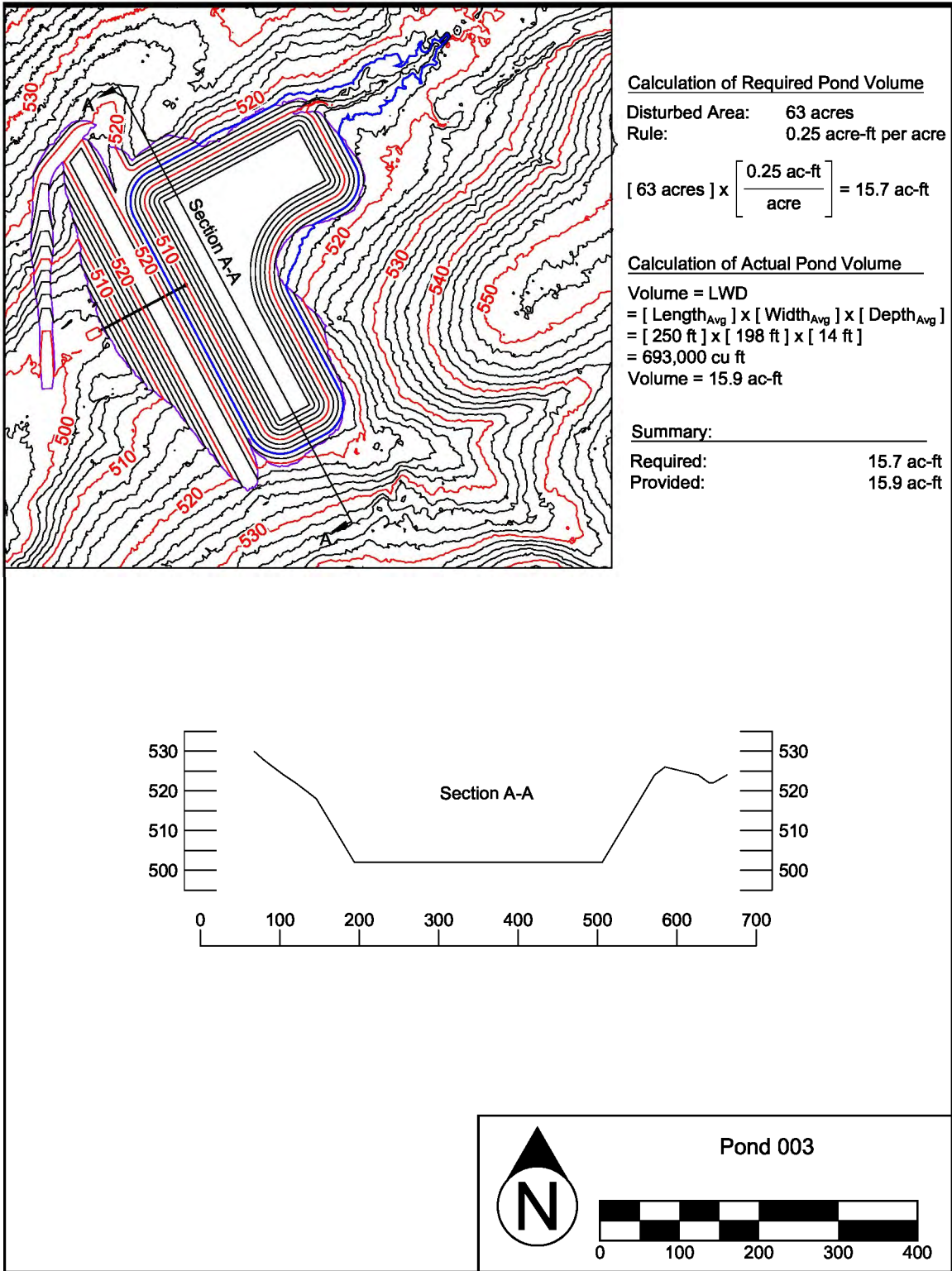

Figure 3-3. Pond 003.

4. Pollution Abatement and Prevention Plan

4.1. Introduction

The plan follows the regulatory outline with each section introduced by the applicable portion of Rule 335-6-9-.03 "Pollution Abatement and/or Prevention Plan".

4.2. Name and Address

335-6-9-.03(2) (a) name and address of the operator and a legal description of the area to be mined.

The operator is Davis Materials, Inc. and the mailing address is as follows:

Davis Materials, Inc.
P.O. Box 1099
Tuscaloosa, AL 35403

The telephone number for the contact at Davis Materials, Inc. is (205) 345-6655 and the contact person is Mr. Ronald T. Davis, Vice-President. The mine is in Tuscaloosa County, Alabama in Sections 17 and 20 of Township 21S and Range 6W.

4.3. General Information

335-6-9-.03(2) (b) general information, including name and affiliation of company, number of employees, product(s) to be mined, hours of operation and water supply and disposition.

The operator is Davis Materials, Inc. There may be as many as 5 full-time employees at the pit. Operation will be 8 hours per day, 5 days per week, but weekends and 12-hour days may be scheduled. The Vance Pit will produce crushed stone aggregate for commercial use. The aggregate may be used in the production of concrete. Water from mine de-watering activities and stormwater will be treated in Ponds 001, 002, and 003 prior to discharge.

4.4. Topographic Map

335-6-9-.03(2) (c) topographic map showing location of mine, preparation plant, settling basin and all waste water discharge points.

Figure 1-1 is a topographic map which shows the location of the mine, the settling basins, and the water discharge points. An office, crushing, screening, and other facilities may be located at the site marked "staging area" on the topographic map.

4.5. Diversions

335-6-9-.03(2) (d) method and plan for diverting surface water runoff from operational areas and mineral and refuse storage piles.

No diversions exist and none are proposed.

4.6. Operations

335-6-9-.03(2)(e) narrative account of operation(s) explaining and/or defining raw materials, processes and products. Blockline or schematic diagrams indicating points of waste origin and its collection and disposal shall be included.

Overburden will be removed by excavating equipment to expose the stone (normally, limestone). The overburden that is suitable for use as topsoil may be stockpiled for reclamation or to develop vegetative cover. Overburden that is not suitable for use as topsoil may be used to construct runoff control structures or may be stockpiled separately for use as fill soil.

Heavy equipment, along with drilling and blasting, will be used to mine the stone. Following mining, the broken aggregate will be loaded into trucks and transported. Davis Materials, Inc. may also conduct mineral dry and wet processing (crushing, screening, and washing) within the watershed.

Waste products generated as a result of the mining operation are sediments from disturbed areas, transported by rainfall runoff or pumped discharges. Wet processing may also generate sediments. The source of the wet processing water will be the sedimentation pond and the water will return to the sedimentation pond after use. The sediments will originate in the mine, spoil areas, or other disturbed areas. The sediments will be transported by rainfall runoff, wet process return flow, or by pumping to the sedimentation pond. The sediments will be captured by detaining the water in the sedimentation pond. When necessary, the accumulated sediments will be removed from the sedimentation pond. A schematic is given in Figure 4-1.

4.7. Waste Characteristics

335-6-9-.03(2)(f) quantity and characteristics of waste after treatment with respect to flow, suspended solids, total iron, and pH.

Assuming an average annual rainfall of 54 inches and an average runoff coefficient of 50%, runoff should be approximately 2,000 gallons per day per acre of watershed. Using the factor, the average daily flow from DSN001E is 74,000 gallons per day (gpd); the average daily flow from DSN002E is 42,000 gallons per day; and the average daily flow from DSN003P will be 136,000 gallons per day. Discharged water will comply with permit limits with regard to suspended solids, total iron, and pH.

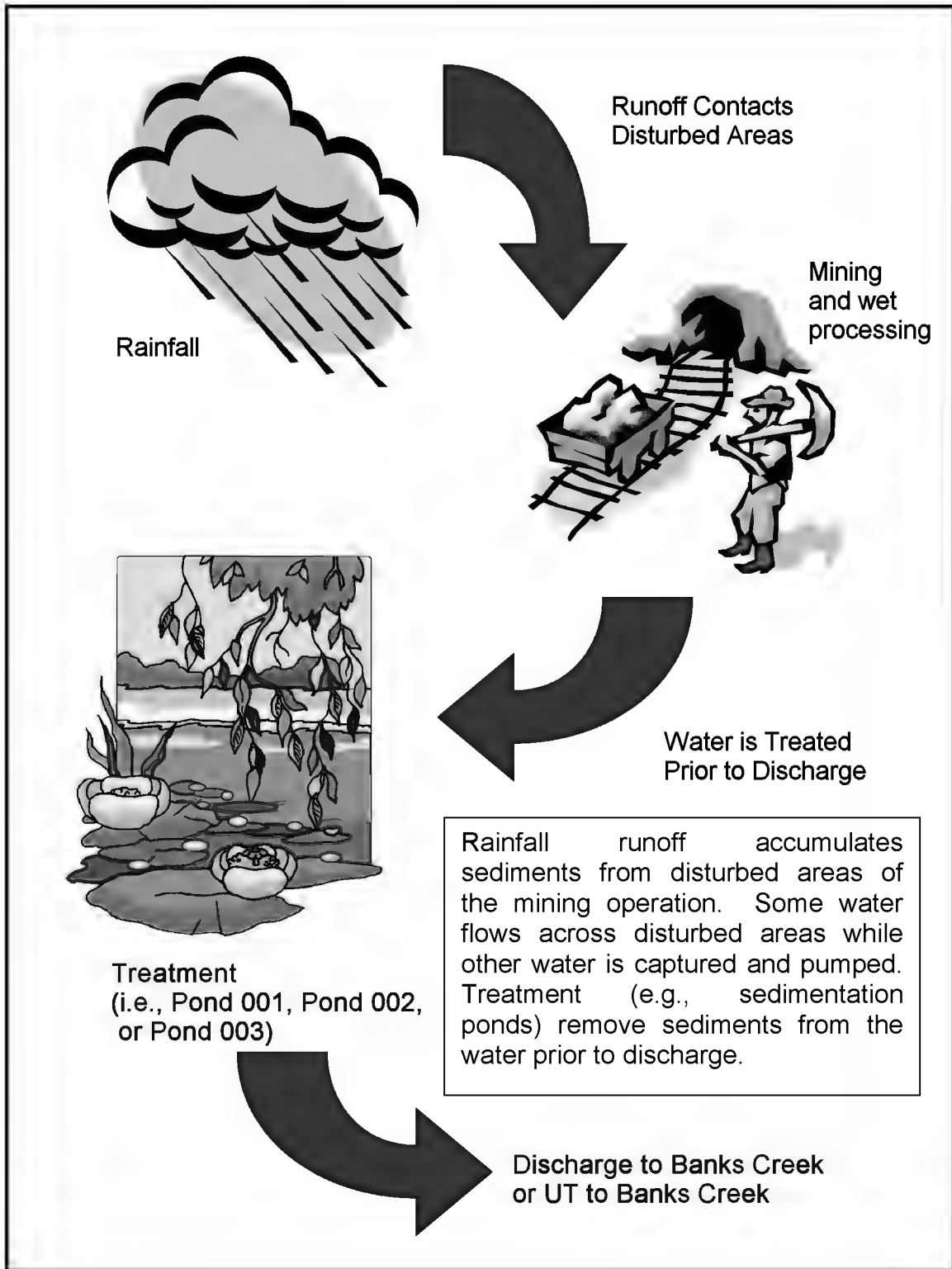

Figure 4-1. Waste Schematic.

4.8. Waste Treatment Facilities

335-6-9-.03(2) (g) description of waste treatment facilities, pretreatment measures and recovery systems including expected life of sedimentation basins and schedules for cleaning or proper abandonment of such basins. If earthen sedimentation basins are a portion of the treatment scheme, plans for the construction of these facilities should meet minimum construction criteria as found in the Guidelines in Appendix A.

The waste treatment facilities consist of the sedimentation controls, especially the sedimentation ponds, described in Chapter 3. The proposed ponds; Pond 001, Pond 002, and Pond 003; meet the minimum construction criteria as found in the Guidelines in Appendix A. Pond 001, Pond 002, and Pond 003 will serve to satisfy the regulatory requirements for sediment storage and detention. The expected life of the sedimentation basins is the life of the mine and the ponds will be cleaned out when sediment accumulation is 60% of design capacity. The ponds will be maintained for the life of the permit.

4.9. Haul Road Sediment Control

335-6-9-.03(2) (h) a plan to eliminate or minimize sediment and other pollutants from haul roads must be included and should meet minimum design criteria as established by the Guidelines in Appendix B.

The haul roads meet the specifications listed below:

- 1) No sustained grade will exceed 10 percent;
- 2) The maximum grade will not exceed 15 percent for 300 feet. There will be no more than 300 feet of 15 percent maximum grade for each 1000 feet of road constructed;
- 3) Haul roads within the mining area will be constructed so that runoff from the road is routed to the sedimentation basin;
- 4) Outer slopes for haul roads out of the permitted area will not be steeper than 2:1 and will be lined with natural vegetation to avoid erosion;
- 5) Roads will be surfaced with either slag, chert, crushed limestone, crushed sandrock, or red rock, other than temporary roads for limited access; and
- 6) There will be no creek crossings.

4.10. Stream Impact Minimization

335-6-9-.03(2) (I) location of all streams in or adjacent to the mining area and those measures which will be taken to minimize the impact on water quality when the mining operation is located in close proximity to such streams. Such measures may include but not be limited to setbacks, buffer strips, or screens.

The operation drains to Banks Creek. Davis Materials, Inc. will operate behind an embankment constructed along Banks Creek, and by this means implement and maintain a 50 foot setback from waters of the State. An obvious exception involves the erosion control measures (e.g., rock rip rap in channels) from the sedimentation ponds to Banks Creek. The sedimentation controls, especially the sedimentation ponds, described in Chapter 3 are intended to minimize any negative stream impacts.

4.11. Non-Point Impact Minimization

335-6-9-.03(2)(j) those measures to be employed to minimize the effect of any non point source pollution which may be generated as a result of the surface mining operation.

The surface runoff from mined areas generally drains to Pond 001 or to Pond 002. Any negative impacts from non-point discharges will be minimized using best management practices.

4.12. Construction Certification

335-6-9-.03(2)(k) all pollution abatement facilities must be certified by the design engineer as being constructed in accordance with the approved plans.

The existing ponds, Pond 001 and Pond 002, are already certified. The proposed pond, Pond 003, will be certified by an engineer after construction.

4.13. Watershed Classification

335-6-9-.03(2)(l) the applicant shall specify if the proposed mining operation is to be constructed in the watershed of an impoundment classified as a public water supply or a direct tributary thereon.

This facility does not discharge into a stream segment classified as a Public Water Supply. The mining operation drains to Banks Creek. As the water continues downstream it enters Hill Creek, then Schultz Creek, and the Cahaba River. Schultz Creek enters the Cahaba River approximately 3.3 miles north from Centreville.

4.14. Facility Closure Plan

Specific closure plans will be submitted as necessary at the time of closure. At a minimum all areas will be reclaimed and grassed to the standards established by ADEM.

5. Best Management Practices Plan

5.1. Introduction

In response to the Water Quality Act of 1987, the Environmental Protection Agency (EPA) expanded the National Pollutant Discharge Elimination System (NPDES). The expanded permit system is for many types of discharges including industrial storm water discharges. The EPA's storm water program emphasizes pollution prevention and reflects a heavy reliance on Best Management Practices (BMP) Plans to reduce pollutant loadings and improve water quality. BMP's are defined as schedules of activities, prohibitions of practices, maintenance procedures, and other management practices to prevent or reduce the pollution of waters of the United States. BMP's also include treatment requirements, operating procedures, and practices to control facility site runoff, spillage or leaks, sludge or water disposal, or drainage from raw material storage.

Previous chapters presented sediment control structures along with the Pollution Abatement and Prevention Plan to minimize discharges of sediments and other pollutants. Other control features could also be helpful. For example, upstream sediment traps could decrease the volume of sediment collected in Pond 001, increasing its life. This comprehensive BMP Plan has been prepared for the prevention and minimization of all sources of pollution in discharges from mine de-watering activities and stormwater for this site utilizing effective BMP's from the *Alabama Handbook for Erosion Control, Sediment Control, And Stormwater Management On Constructions Sites And Urban Areas*, by the Alabama Soil and Water Conservation Committee.

5.2. Excerpts

Several excerpts from the *Alabama Handbook for Erosion Control, Sediment Control, and Stormwater Management on Constructions Sites and Urban Areas*, are included at the end of this chapter. The excerpts describe vegetation preservation, dust control (including mulching and permanent seeding), sediment traps (including straw bale traps, sediment barriers, and temporary excavations), and the sedimentation pond (including outlet protection). If other portions of the Handbook prove useful they may be incorporated.

Preservation of Vegetation (PV)



Practice Description

Preservation of vegetation is the avoidance of an area during land disturbing and construction activity to prevent mechanical and other injury to desirable plants in the planned landscape. The practice provides erosion and sediment control and is applicable where vegetative cover is desired and the existing plant community is compatible with the planned landscape.

Planning Considerations

Preservation of vegetation requires good site management to minimize the impact of construction activities on existing vegetation.

Plants to save should be identified prior to any construction activity.

Proper maintenance, especially during construction, is important to ensure healthy vegetation that can control erosion.

Different species, soil types, and climatic conditions will require different maintenance activities.

Design Criteria

Mark Plant Area for Retention

Groups of plants and individual trees to be retained should be located on a plan map. Limits of clearing should be planned outside the drip line of groups or individual trees to be saved. The clearing should never be closer than 5 feet to the trunk of a tree.

Flagging or other appropriate means of marking the site of the groups of plants and individual trees to be retained should be required before construction begins. Individual trees to be retained should be marked with a highly visible paint or surveyor's ribbon in a band circling the tree at a height visible to equipment operators.

Plant Protection

Restrict construction equipment, vehicular traffic, stockpiles of construction materials, topsoil etc., from the areas where plants are retained and restrict these activities from occurring within the drip line of any tree to be retained. Trees being removed shall not be pushed into trees to be retained. Equipment operators shall not clean any of their equipment by slamming it against trees to be retained.

Restrict burning of debris within 100 feet of the plants being preserved. Fires shall be limited in size to prevent damage to any nearby trees.

Toxic material shall not be stored any closer than 100 feet to the drip line of any trees to be retained. Toxic materials shall be managed and disposed of according to state laws.

Fencing and Armoring

Groups of plants and trees should be protected by fencing or armoring where necessary (See Figure PV-1). The following types of fencing or armoring may be used:

- Board Fence-Board fence may be constructed with 4" square posts set securely in the ground and protruding at least 4 feet above the ground. A minimum of 2 horizontal boards should be placed between the posts. The fence should be placed at the limits of the clearing around the drip line of the tree. If it is not practical to erect a fence at the drip line, construct a triangular fence near the trunk. The limits of clearing will still be the drip line as the root zone within the drip line will still require protection.
- Cord Fence-Posts at least 2" square or 2" in diameter set securely in the ground and protruding at least 4 feet above the ground shall be placed at the limits of clearing with 2 rows of cord ¼" or thicker at least 2 feet apart running between posts with strips of surveyor's tape tied securely to the string at intervals of 3 feet or less.

- Earth Berms-Temporary earth berms may be constructed. The base of the berm on the tree side should be located along the limits of clearing. Earth berms may not be used for this purpose if their presence will create drainage patterns that cause erosion.
- Additional Trees-Additional trees may be left standing as protection between the trees to be retained and the limits of clearing. However, in order for this alternative to be used, trees in the buffer must be no more than 6 feet apart to prevent passage of equipment and material through the buffer.
- Plan for these additional trees to be evaluated prior to the completion of construction and either given sufficient treatment to ensure survival or be removed.
- Trunk Armoring-As a last resort, a tree may be armored with burlap wrapping and 2” studs wired vertically no more than 2” apart to a height of 5 feet. The armoring should encircle the tree trunk. Nothing should ever be nailed to a tree. The root zone within the drip line will still require protection.
- Fencing and armoring devices should be in place before any construction work is done and should be kept in good condition for the duration of construction activities. Fencing and armoring should not be removed until the completion of the construction project.

Raising the Grade

When the ground level must be raised around an existing tree or group of trees several methods may be used to insure survival.

A well may be created around a group of trees or an individual tree slightly beyond the drip line to retain the natural soil in the area of the feeder roots (see Figure PV-2).

When the well alternative is not practical or desirable, remove vegetation and organic matter from beneath the tree or trees for a distance of 3 feet beyond the drip line and loosen the surface soil to a depth of approximately 3” without damaging the roots.

Apply fertilizer in the root area of the tree to be retained. A soil test is the best way to determine what type of fertilizer to use. In the absence of a soil test, fertilizer should be applied at the rate of 1 to 2 pounds of 10-8-6 or 10-6-4 per inch of diameter at breast height (dbh) for trees under 6” dbh and at the rate of 2 to 4 pounds of 10-8-6 or 10-6-4 per inch of dbh for trees over 6” dbh.

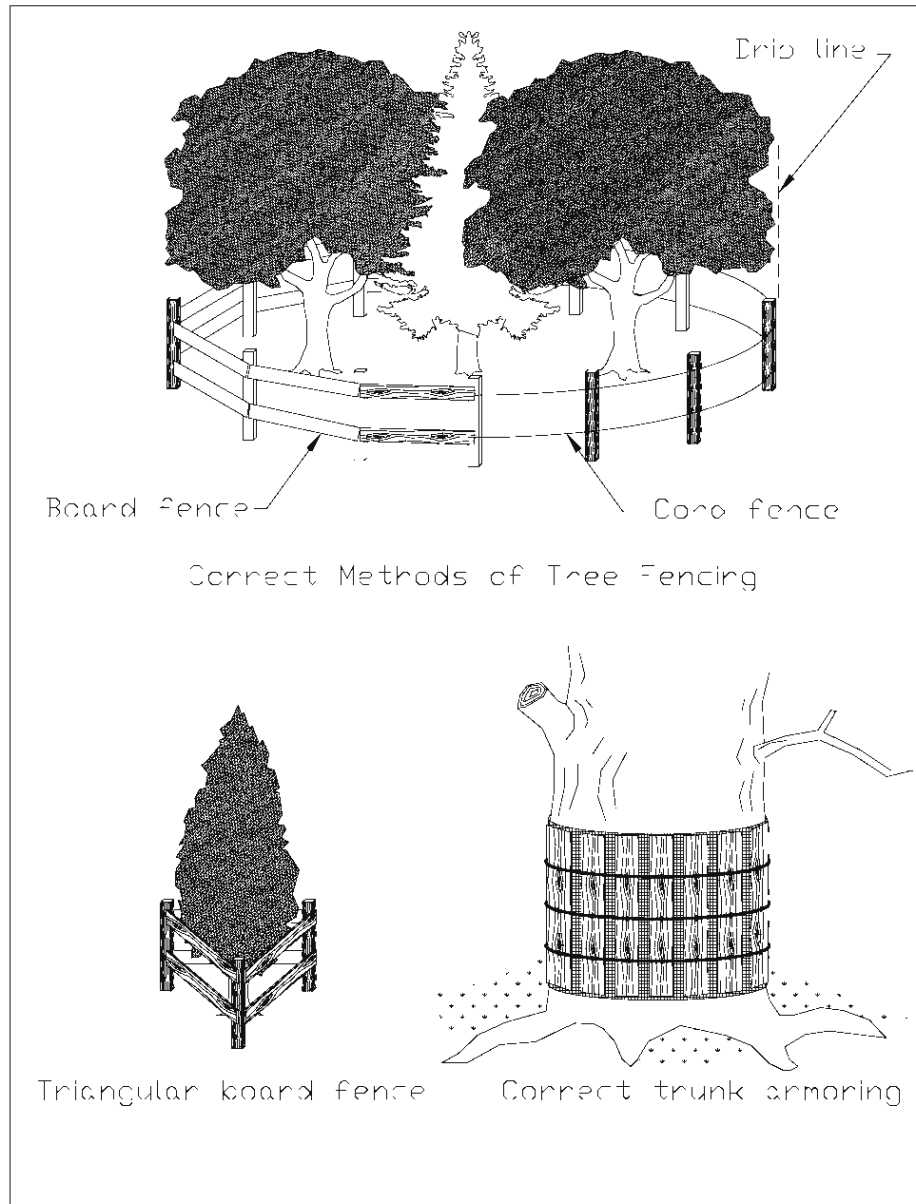

Figure PV-1 Fencing and Armoring

A dry well shall be constructed so as to allow for tree trunk diameter growth (see Figure PV-3). A space of at least 1 foot between the tree trunk and the well wall is adequate for old, slow growing trees. Clearance for younger trees shall be at least 2 feet. The well shall be high enough to bring the top just above the level of the proposed fill. The well wall shall taper slightly away from the tree trunk at a rate of 1" per foot of wall height.

The well wall shall be constructed of large stones, brick, building tile, concrete blocks, or cinder blocks. Openings should be left through the wall of the well to allow for free movement of air and water. Mortar shall only be used near the top of the well and only above the porous fill.

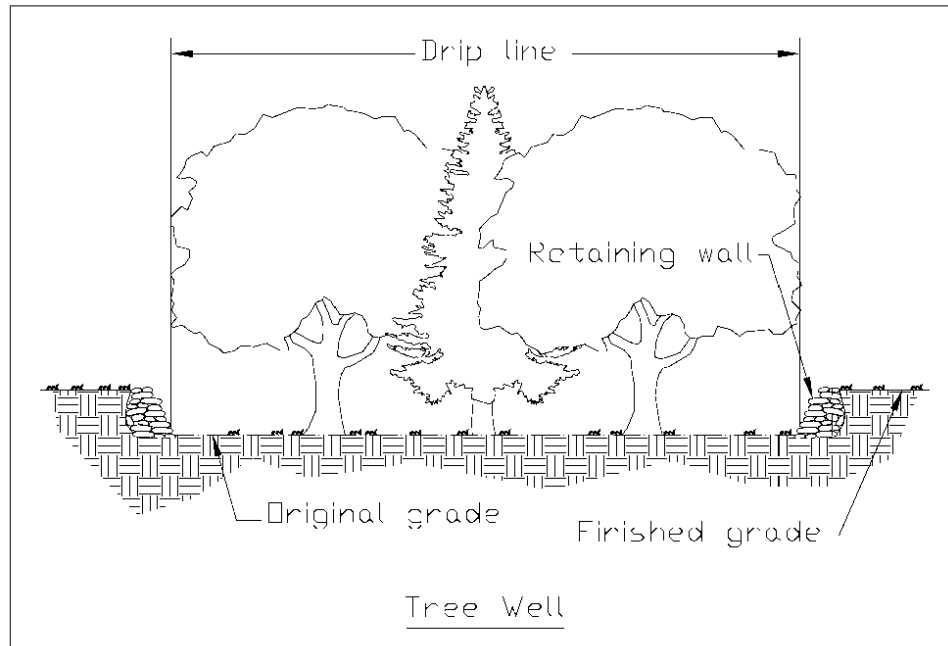

Figure PV-2 Tree Well

Drain lines composed of 4" high quality drain tiles shall begin at the lowest point inside the well and extend outward from the tree trunk in a wheel and spoke pattern with the trunk as the hub. Radial drain lines shall slope away from the well at a rate of $\frac{1}{8}$ " per foot. The circumference line of tiles should be located beneath the drip line of the trees. Vertical tiles or pipes shall be placed over the intersections of the two tile systems if a fill of more than 2 feet is contemplated. Vertical tiles shall be held in place with stone fill. Tile joints shall be tight. A few radial tiles shall extend beyond each intersection and shall slope sharply downward to insure good drainage. Tar paper or its approved equivalent shall be placed over the tile and/or pipe joints to prevent clogging and large stone shall be placed around and over drain tiles and/or pipes for protection.

A layer of 2" to 6" of stone shall be placed over the entire area under the tree from the well outward at least as far as the drip line. For fills up to 2 feet deep, a layer of stone 8" to 12" thick should be adequate.

A thick layer of this stone not to exceed 30" will be needed for deeper fills. A layer of $\frac{3}{4}$ " to 1" stone covered by straw, fiberglass mat or a manufactured filter fabric shall be used to prevent soil from clogging the space between stones. Cinders shall not be used as fill material. Filling shall be completed with porous soil such as topsoil until the desired grade is reached. This soil shall be suitable to sustain specified vegetation.

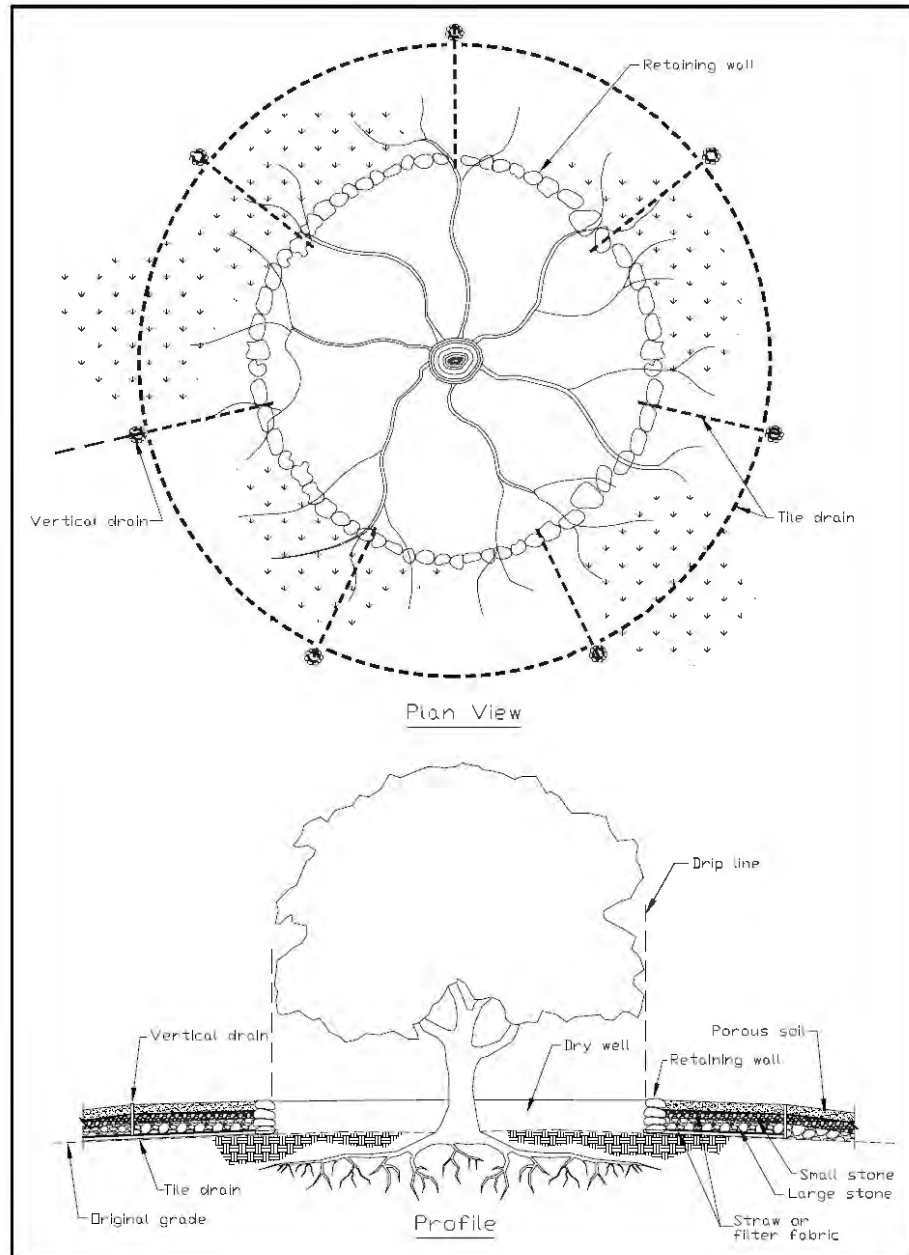

Figure PV-3 Tree Well Detail

Crushed stone shall be placed inside the dry well over the openings of the radial tiles to prevent clogging. The area between the trunk and the well wall shall either be covered by an iron grate or filled with a 50-50 mixture of crushed charcoal and sand to prevent anyone from falling into the dry well.

Where water drainage through the soil is not a problem, coarse gravel in the fill may be substituted for the tile. This material has sufficient porosity to ensure air drainage. Instead of the vertical tiles or pipes in the system, stones, crushed rock and gravel may be added so that the upper level of these porous materials slants toward the surface in the vicinity below the drip line.

Raising the grade on only one side of a tree or group of trees may be accomplished by constructing only half of one of these systems.

Lowering the Grade

Shrubs and trees shall be protected from the harmful grade cuts by the construction of a tree wall (see Figure PV-4). Following excavation, all tree roots that are exposed and/or damaged shall be trimmed cleanly and covered with moist peat moss, burlap or other suitable material to keep them from drying out.

The wall shall be constructed of large stones, brick, building tile, concrete block or cinder block. The wall should be backfilled with topsoil, peat moss, or other organic matter to retain moisture and aid in root development. Apply fertilizer and water thoroughly. The tree plants should be pruned to reduce the leaf surface in proportion to the amount of root loss. Drainage should be provided through the wall so water will not accumulate behind the wall. Lowering the grade on one side of the tree or group of trees can be accomplished by constructing only half of this system.

Trenching and Tunneling

Trenching should be done as far away from the trunks of trees as possible, preferably outside the branches or crown spreads of trees, to reduce the amount of root area damaged or killed by trenching activities. When possible trenches should avoid large roots or root concentrations. This can be accomplished by curving the trench or by tunneling under large roots and areas of heavy root concentration. Tunneling under a species that does not have a large tap root may be preferable to trenching beside it as it has less impact on root systems (see Figure PV-5).

Roots should not be left exposed to the air but should be covered with soil as soon as possible or protected and kept moist with burlap or peat moss until the trench or tunnel can be filled. The ends of damaged and cut roots shall be cut off smoothly and moist peat moss, burlap or topsoil should be placed over the exposed area.

Trenches and tunnels shall be filled as soon as possible. Care should be taken to ensure that air spaces are not left in the soil. Peat moss or other organic matter shall be added to the fill material as an aid to inducing and developing root growth. The tree should be fertilized and mulched to stimulate new root growth and enhance general tree vigor. If a large part of the root system has been damaged the crown leaf surface area should be reduced in proportion to the root damage. This may be accomplished by pruning 20-30 percent of the crown foliage. If the roots are damaged during the winter the crown should be pruned before the next growing season. If roots are cut during the growing season, pruning should be done immediately.

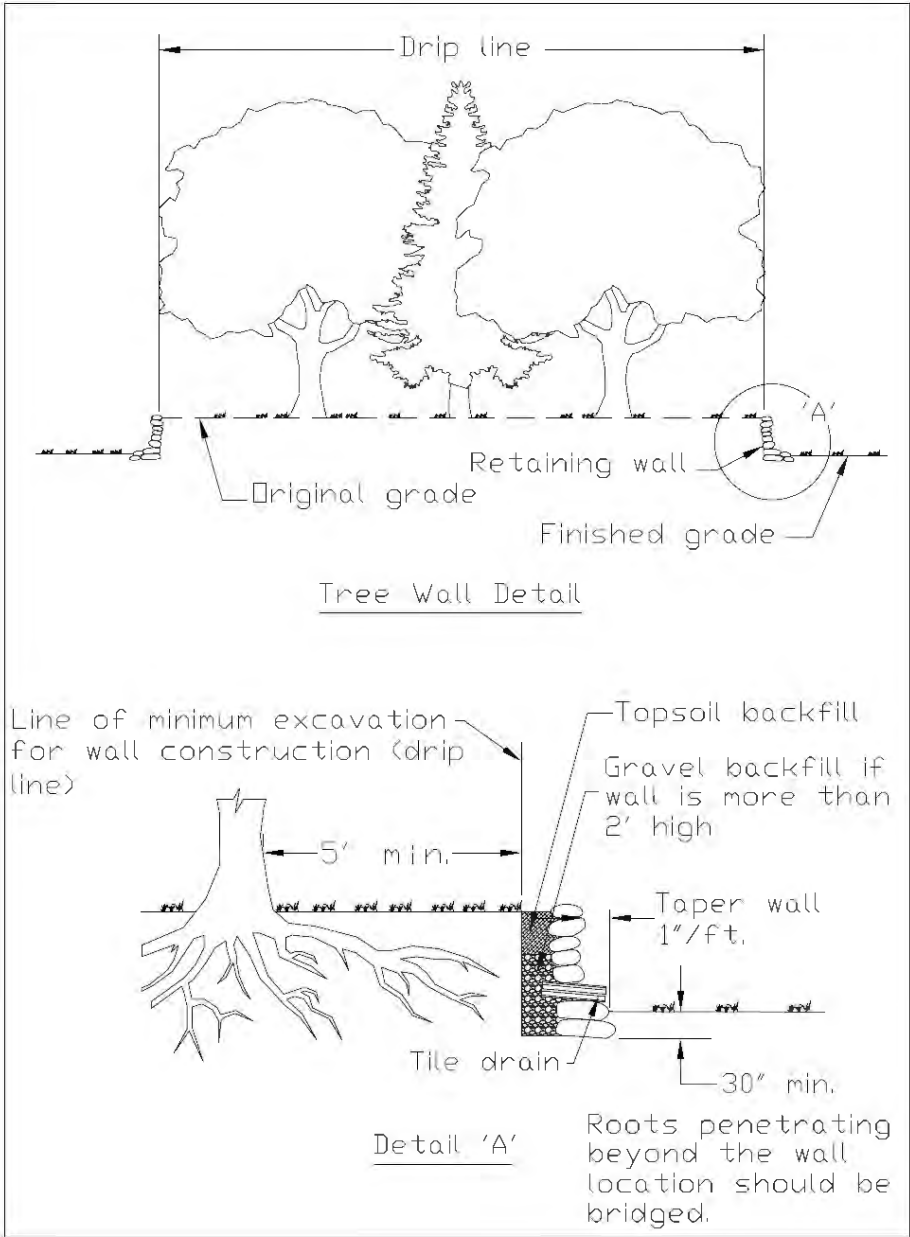

Figure PV-4 Tree Wall Detail

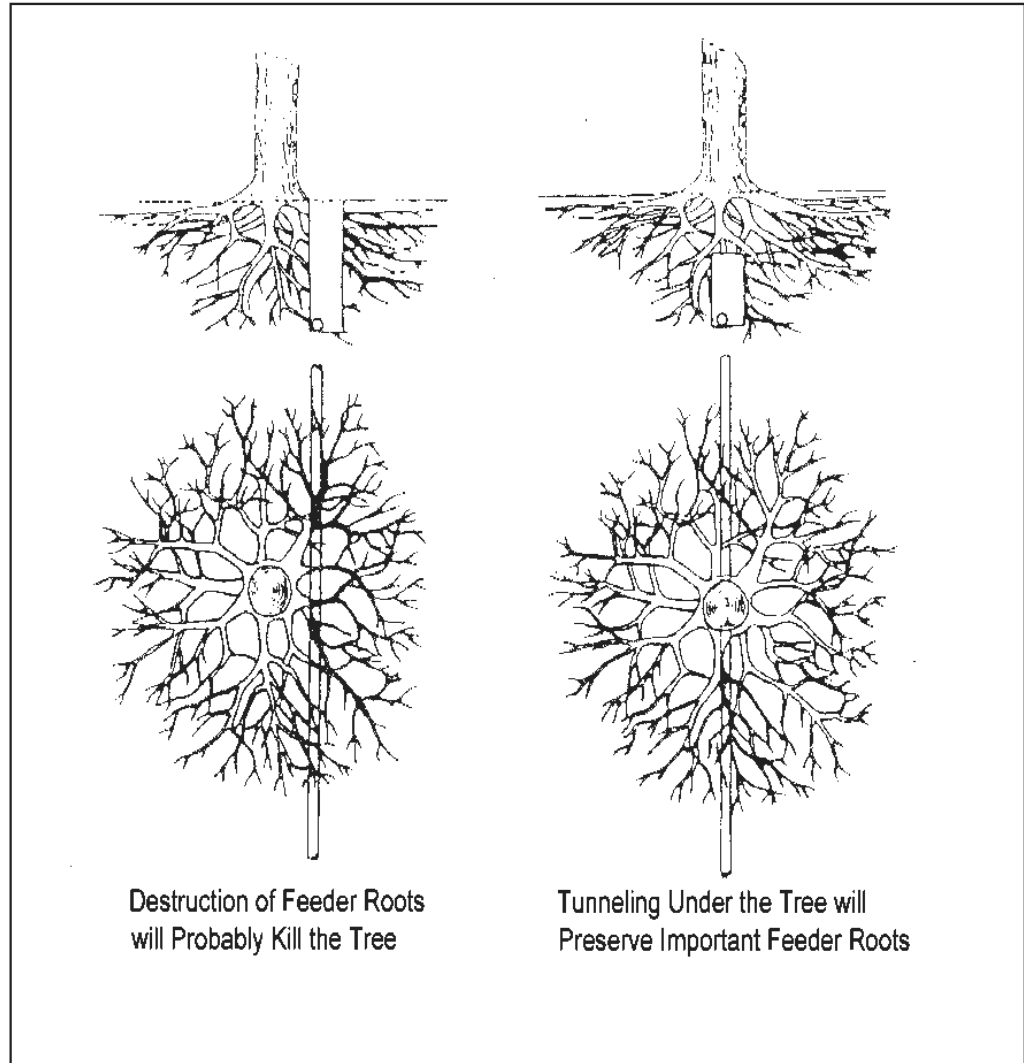

Figure PV-5 Trenching vs Tunneling

Treating Damaged Trees

When trees are damaged during construction activities certain maintenance practices can be applied to protect the health of the tree.

Soil aeration may be needed if the soil has been compacted. The soil around trees can be aerated by punching holes 1 foot deep and 18" apart under the crown of trees with an iron pipe.

Damaged roots should be cut off cleanly and moist peat moss, burlap or topsoil should be placed over the exposed area. Bark damage should be treated by removing loose bark.

Tree limbs damaged during construction or removed for any other reason shall be cut off above the collar at the branch junction.

Trees that have been stressed or damaged should be fertilized to aid their recovery.

Trees should be fertilized in the spring or fall. Fall applications are preferred.

Fertilizer should be applied to the soil over the feeder roots. In no case should it be applied closer than 3 feet to the trunk. Root systems of trees extend some distance beyond the drip line. The area to be fertilized should be increased by $\frac{1}{4}$ the area of the crown. A soil test is the best way to determine what type of fertilizer to use. In the absence of a soil test, fertilizer should be applied at the rate of 1 to 2 pounds of 10-8-6 or 10-6-4 per inch of dbh for trees under 6" dbh and at the rate of 2 to 4 pounds of 10-8-6 or 10-6-4 per inch of dbh for trees over 6" dbh.

A ground cover or organic mulch layer should be maintained around trees to prevent erosion, protect roots and to conserve water.

Dust Control (DC)

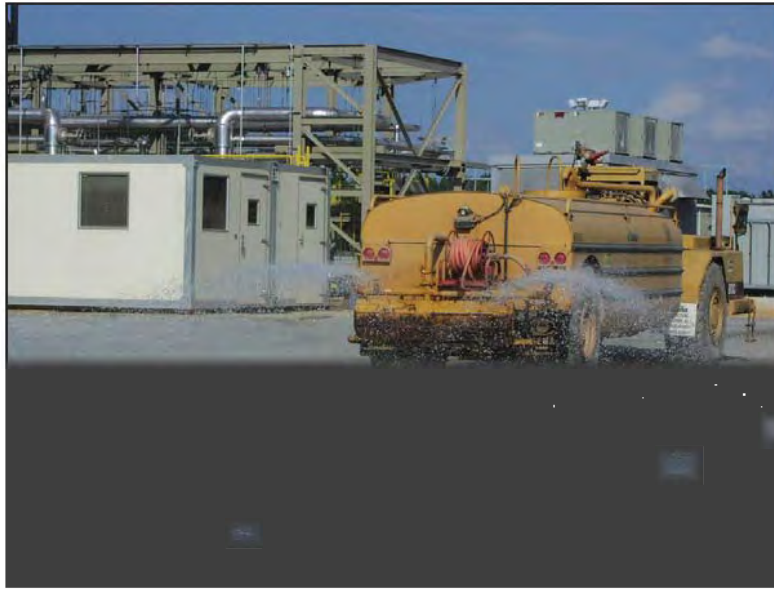

Practice Description

Dust control includes a wide range of techniques that prevent or reduce movement of wind-borne soil particles (dust) during land disturbing activities. This practice applies to construction routes and other disturbed areas where on-site and off-site damage or hazards may occur if dust is not controlled.

Planning Considerations

Construction activities that disturb soil can be a significant source of air pollution. Large quantities of dust can be generated, especially in “heavy” construction activities such as land grading for road construction and commercial, industrial or subdivision development.

The scheduling of construction operations so that the least amount of area is disturbed at one time is important in planning for dust control.

The greatest dust problems occur during dry periods. Therefore, to the extent practicable do not expose large areas of bare soil during drought conditions.

Where wind erosion is a potential cause of dust problems, preserving vegetation should be considered as a passive measure. Leave undisturbed buffer areas between graded areas wherever possible.

Installing temporary or permanent surface stabilization measures immediately after completing land grading will minimize dust problems.

Design Criteria

Permanent Methods

Vegetative Cover

For disturbed areas not subject to traffic, vegetation provides the most practical method of dust control. Establish vegetative cover according to the Permanent Seeding or Temporary Seeding practice.

Topsoiling

This entails covering the surface with less erosive soil material. See Topsoiling practice for guidance.

Stone

Stone used to stabilize construction roads can also be effective for dust control. Stone should be spread a minimum of 6" thick over construction roads in the disturbed area. For heavily traveled roads or roads subjected to heavy loads the stone thickness should be 8" to 10". A non-woven geotextile meeting the minimum requirements of ASSHTO M288 should be used under the stone.

Temporary Methods

Mulches

Mulch offers a fast, effective means of controlling dust when properly applied. See Mulching practice for guidelines for planning and installing the practice.

Temporary Vegetative Cover

For disturbed areas where no activity is anticipated for 14 days or longer, temporary seeding can effectively control dust. Establish vegetative cover according to Temporary Seeding practice guidelines.

Calcium Chloride

Calcium chloride may be applied by mechanical spreader as loose, dry granules or flakes at a rate that keeps the surface moist but not so high as to cause water pollution or plant damage. Sites may need to be retreated because the product degrades over time.

Spray-on Adhesives

Spray-on adhesives may be used on mineral soils for dust control. Traffic must be kept off treated areas to prevent the product from becoming ineffective. Examples of spray-on adhesives for use in dust control are listed in Table DC-1.

Table DC-1 Spray-on Adhesives for Dust Control on Mineral Soil

Material	Water Dilution	Type of Nozzle	Apply Gal/Ac
Anionic Asphalt Emulsion	7:1	Coarse Spray	1,200
Latex Emulsion	12.5:1	Fine Spray	235
Resin In Water	4:1	Fine Spray	300

Chemical Stabilization (CHS)

Chemical products are available for use on mineral soils for dust control. Traffic must be often kept off treated areas to prevent the product from becoming ineffective. The manufacturer or supplier shall provide written application methods. The application method shall ensure uniform coverage to the target and avoid drift to non-target areas including waters of the State. The manufacturer or supplier shall also provide written instructions to ensure proper safety, storage, and mixing of the product. Refer to the Planning Considerations for the Chemical Stabilization practice for planning consideration before deciding to use these type products.

Sprinkling or Irrigation

Sprinkling is especially effective for dust control on haul roads and other traffic routes. Sprinkle the site until the surface is wet. Repeat as needed. Also bare areas may be kept wet with irrigation to control dust as an emergency treatment.

Tillage

Tillage is used to roughen the site and bring clods and moist soil to the surface. This is a temporary emergency measure that can be used on large open disturbed areas as soon as soil blowing starts. Begin tilling on the windward edge of the site. The depth of tillage is determined by the depth to moist soil and the amount of moist soil desired at the surface. In sandy soils, the depth to moist soil may make tillage impractical.

Barriers

A board fence, wind fence, sediment fence, hay bales, or similar barriers can control air currents and blowing soil. Place barriers perpendicular to prevailing air currents at intervals about 15 times the barrier height.

Mulching (MU)



Practice Description

Mulching is the application of plant residues such as straw or other suitable fibrous materials to the soil surface. Mulch protects the soil surface from the erosive force of raindrop impact and reduces the velocity of overland flow. It helps seedlings germinate and grow by conserving moisture, protecting against temperature extremes and controlling weeds. Mulch also maintains the infiltration capacity of the soil. Mulch can be applied to seeded areas to help establish plant cover. It can also be used in unseeded areas to protect against erosion over the winter or until final grading and shaping can be accomplished except in areas with concentrated flow.

Planning Considerations

Surface mulch is the most effective, practical means of controlling runoff and erosion on disturbed land prior to vegetation establishment. Mulch absorbs the energy associated with raindrops and thereby minimizes soil particle detachment, which is the initiation step of erosion.

Mulch also reduces soil moisture loss by evaporation, prevents crusting and sealing of the soil surface, moderates soil temperatures, and provides a suitable microclimate for seed germination.

Organic mulches such as straw, wood chips and shredded bark have been found to be very effective mulch materials. Materials containing weed and grass seeds which may compete with establishing vegetation should not be used. Also, decomposition of some wood products can tie up significant amounts of soil nitrogen, making it necessary to modify fertilization rates or add fertilizer with the mulch.

Hydraulic Erosion Control Products (HECPs) as defined by the Erosion Control Technology Council (ECTC) can also be used as effective mulch applications. HECPs are designated as 5 different types based on product characteristics and performance. Information from the ECTC table dated August 2010 is provided as Table MU-1. To ensure that you use the most valid information refer to the latest HECP specifications provided by the ECTC or the manufacturer's recommendation. The Alabama Department of Transportation (ALDOT) characterizes mulches based on performance levels identified in Sections 656 and 659 of their Standard Specifications for Highway Construction.

The choice of materials for mulching should be based on soil conditions, season, type of vegetation to establish, and size of the area. Properly applied and tacked mulch is always beneficial. Mulching is especially important when conditions of germination are not optimum, such as midsummer and early winter, and on difficult sites such as cut slopes, fill slopes and droughty soils.

Straw has traditionally been the most commonly used mulching material in conjunction with seeding. Wheat straw is the mostly commonly used straw, and can be spread by hand or with a mulch blower. If the site is susceptible to blowing wind, the straw should be tacked down with a tackifier, or a crimper to prevent loss.

Wood chips are suitable for areas that will not be closely mowed, and around ornamental plantings. Chips do not require tacking. Because they decompose slowly they must be treated with 12 pounds of nitrogen per ton to prevent nutrient deficiency in plants. They can be an inexpensive mulch if the chips are obtained from trees cleared on the site.

Compost, peanut hulls, and pine straw are organic materials that potentially make excellent mulches but may only be available locally or seasonally. Creative use of these materials may reduce costs.

Jute mesh or the various types of netting is very effective in holding mulch in place on waterways and slopes before grasses become established.

Erosion control blankets promote seedling growth in the same way as organic mulches and are suited for use in areas with concentrated flows (see Erosion Control Blanket practice).

Table MU-1 Hydraulic Erosion Control Products (HECP) Specification Chart ¹

Hydraulic Erosion Control							
Type HECP ²	Term	Functional Longevity ³	Typical Application Rates Lbs/acre (kg/ha)	Typical Maximum Slope Gradient (H:V)	Maximum Uninterrupted Slope Length (ft)	Maximum C Factor ^{4, 5} (3:1 test)	Minimum Vegetation Establishment ⁶
1	Ultra Short	1 month	1500—2500 (1700—2800)	≤ 4:1	20	0.75	150 %
2	Short Term	2 month	2000—3000 (2250—3400)	≤ 3:1	25	0.5	150 %
3	Moderate	3 month	2000—3500 (2250—3900)	≤ 2:1	50	0.15	200 %
4	Extended Term	6 month	2500—4000 (2800—4500)	≤ 1:1	75	0.1	300 %
5	Long Term	12 month	3000—4500 (3400—5100)	≤ 0.5:1	100	0.02	400 %

¹ This table is for general guidelines only. Refer to manufacturer for application rates, instructions, gradients, maximum continuous slope lengths and other site specific recommendations.

² These categories are independent of rolled erosion control products (RECPs) categories, despite the identical names.

³ A manufacturer’s estimated time period, based upon field observations, that a materials can be anticipated to provide erosion control as influenced by its composition and site-specific conditions.

⁴ “C” Factor calculated as ratio of soil loss from HECP protected slope (tested at specified or greater gradient, h:v) to ratio of soil loss from unprotected (control) plot based on large-scale testing.

⁵ Acceptable large-scale test methods may include ASTM D 6459, or other independent testing deemed acceptable by the engineer.

⁶ Minimum vegetation establishment is calculated as outlined in ASTM D 7322 being a percentage by dividing the plant mass per area of the protected plot by the plant mass per area of the control plot.

EROSION CONTROL TECHNOLOGY COUNCIL —WWW.ECTC.ORG

ECTC makes no representations or warranties of any kind express or implied, about the completeness, accuracy, reliability, suitability or availability with respect to the website or the information, products, services, or related graphics contained on the website for any purpose. Any reliance you place on such information is therefore strictly at your own risk.

(Source: Erosion Control Technology Council, August 2010)

Design Criteria

Site Preparation

Before mulching, complete the required site preparation. Site preparation includes grading, if needed, and seedbed preparation and fertilizing, liming and seeding if a planting is being made by means other than hydroseeding.

Spreading the Mulch

Select a mulch material based on the site and practice requirements, availability of material, and availability of labor and equipment. Table MU-2 lists commonly used mulches.

Table MU-2 Mulching Materials and Application Rates

Material	Rate Per Acre and (Per 1000 ft. ²)	Notes
Straw with Seed	1 ½-2 tons (70 lbs-90 lbs)	Spread by hand or machine to attain 75% groundcover; anchor when subject to blowing.
Straw Alone (no seed)	2 ½-3 tons (115 lbs-160 lbs)	Spread by hand or machine; anchor when subject to blowing.
Wood Chips	5-6 tons (225 lbs-270 lbs)	Treat with 12 lbs. nitrogen/ton.
Bark	35 cubic yards (0.8 cubic yard)	Can apply with mulch blower.
Pine Straw	1-2 tons (45 lbs-90 lbs)	Spread by hand or machine; will not blow like straw.
Peanut Hulls	10-20 tons (450 lbs-900 lbs)	Will wash off slopes. Treat with 12 lbs. nitrogen/ton.
HECPs	0.75 – 2.25 tons (35 lbs – 103 lbs)	Refer to ECTC or Manufacturer's Specifications.

Uniformly spread organic mulches by hand or with a mulch blower at a rate which provides about 75% ground cover. Spread HECPs utilizing appropriate equipment and at rates as specified. When spreading straw mulch by hand, divide the area to be mulched into sections of approximately 1000 sq. ft. and place 70-90 pounds of straw (1 ½ to 2 bales) in each section to facilitate uniform distribution. Caution, an over-application of wheat straw will reduce stand success – do not over-apply wheat straw when mulching a seeding!

When straw mulch is subject to be blown away by wind, it must be anchored immediately after spreading. It is best anchored with a mulch anchoring tool.

Application of a commercial tackifier through a hydroseeder is often practical for steep slopes and can be effective on most sites. Binders (tackifiers) may be applied after mulch is spread or may be sprayed into the mulch as it is being

blown onto the soil. Applying straw and binder together is the most effective method. Liquid binders include an array of commercially available synthetic binders and organic tackifiers.

In high wind situations like roadways, crimping the mulch is the best alternative as the use of mulch binders may still result in the mulch being rolled up on the edge.

Straw mulch may also be anchored with lightweight plastic, cotton, jute, wire or paper netting which is stapled over the mulch. The manufacturer's recommendations on stapling netting should be followed.

Maintenance

Inspect all mulches periodically, and after rainstorms to check for rill erosion, dislocation, or failure. Where erosion is observed, apply additional mulch or if washout has occurred, repair the slope grade, reseed, and reinstall mulch. Continue inspections until vegetation is firmly established.

Permanent Seeding (PS)



Practice Description

Permanent seeding is the establishment of perennial vegetation on disturbed areas from seed. Permanent vegetation provides economical long-term erosion control and helps prevent sediment from leaving the site. This practice is used when vegetation is desired and appropriate to permanently stabilize the soil.

Planning Considerations

The advantages of seeding over other means of establishing plants include the smaller initial cost, lower labor input, and greater flexibility of method.

Disadvantages of seeding include potential for erosion during the establishment stage, seasonal limitations on suitable seeding dates, and weather-related problems such as droughts.

The probability of successful plant establishment can be maximized through good planning. The selection of plants for permanent vegetation must be site specific. Factors that should be considered are type of soils, climate, establishment rate, and management requirements of the vegetation. Other factors that may be important are wear, mowing tolerance, and salt tolerance of vegetation.

Plant selection for permanent vegetation should be based on plant characteristics, site and soil conditions, time of year of planting, method of planting, and the intended use of the vegetated area. Climate factors can vary widely in Alabama.

Important plant attributes are discussed in Vegetation Establishment for Erosion and Sediment Control in Chapter 2.

Plant selection may include companion plants to provide quick cover on difficult sites, late seedings, or where the desired permanent cover may be slow to establish. Annuals are usually used for companion plants and should be selected carefully to prevent using a species that provide so much competition that it prevents the establishment of the desired species.

Seeding properly carried out within the optimum dates has a higher probability of success. It is also possible to have satisfactory establishment when seeding outside these dates. However, as plantings are deviated from the optimum dates, the probability of failure increases rapidly. Seeding dates should be taken into account in scheduling land-disturbing activities.

Site quality impacts both short-term and long-term plant success. Sites that have compacted soils, soils that are shallow to rock or have textures that are too clayey or too sandy should be modified whenever practical to improve the potential for plant growth and long-term cover success.

The operation of equipment is restricted on slopes steeper than 3:1, severely limiting the quality of the seedbed that can be prepared. Provisions for establishment of vegetation on steep slopes can be made during final grading. In construction of fill slopes, for example, the last 4-6" might not be compacted. A loose, rough seedbed with irregularities that hold seeds and lime and fertilizer is essential for hydroseeding. Cut slopes should be roughened (see Land Grading practice).

Proper mulching is critical to protect against erosion on steep slopes. When using straw, anchor with netting or asphalt. On slopes steeper than 2:1, jute, excelsior, or synthetic matting may be required.

The use of irrigation (temporary or permanent) will greatly improve the success of vegetation establishment.

Design Criteria

Plant Selection

Select plants that can be expected to meet planting objectives. To simplify plant selection, use Figure PS-1 Geographical Areas for Species Adaptation and Seeding Dates and Table PS-1, Commonly Used Plants for Permanent Cover. Mixtures commonly specified by the Alabama Department of Transportation are an appropriate alternative for plantings on rights-of-ways. Additional information related to plants commonly used in Alabama is found in Chapter 2 under the section Vegetation for Erosion and Sediment Control.

The plants used for temporary vegetation may be used for companion plants provided the seeding rate of the annual species is reduced by one half. See the Temporary Seeding practice for additional information on establishing temporary

vegetation. **Ryegrass or other highly competitive plants should not be used as a companion plant.**

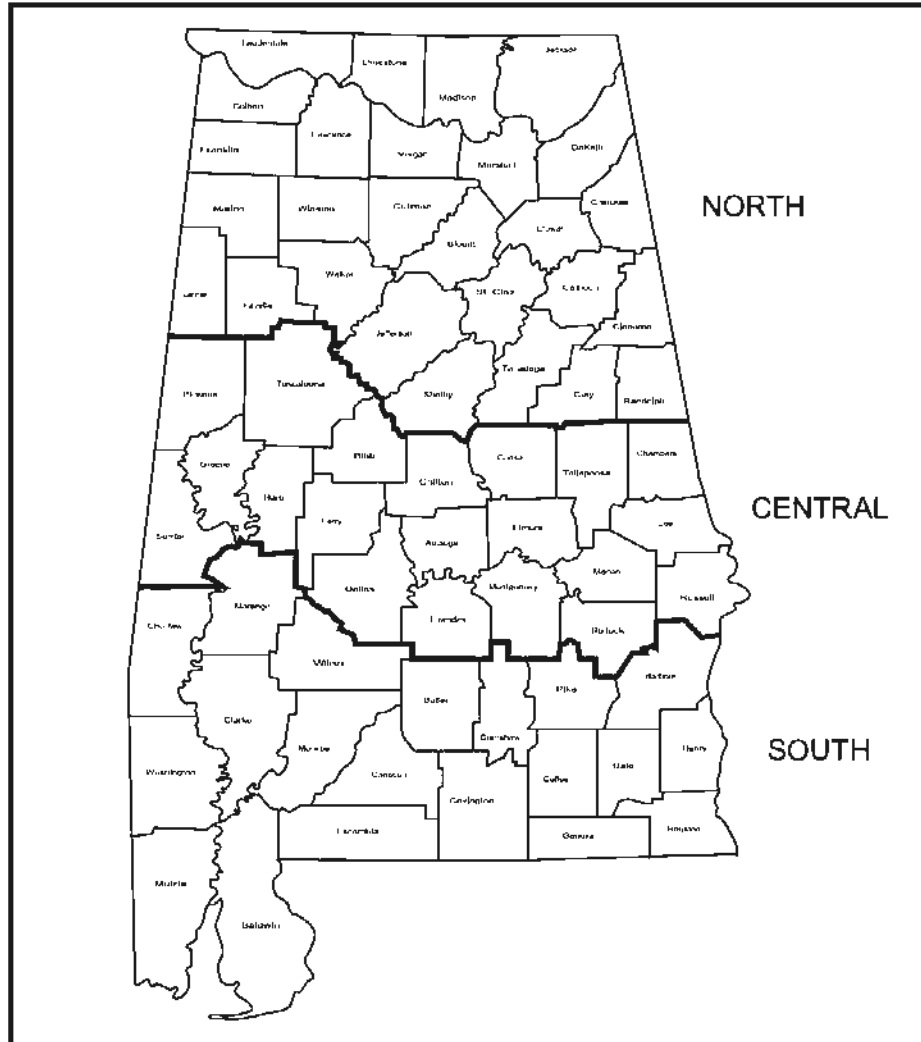

Figure PS-1 Geographical Areas for Species Adaptation and Seeding Dates

Note: Site conditions related to soils and aspect in counties adjacent to or close to county boundaries may justify adjustments in planting dates by qualified design professionals.

Table PS-1 Commonly Used Plants for Permanent Cover with Seeding Rates and Dates

Species	Seeding Rates/Ac PLS	Seeding Dates		
		North	Central	South
Bahiagrass, Pensacola	40 lbs	--	Mar 1-July 1	Feb 1-Nov 1
Bermudagrass, Common	10 lbs	Apr 1-July 1	Mar 15-July 15	Mar 1-July 15
Bahiagrass, Pensacola Bermudagrass, Common	30 lbs 5 lbs	--	Mar 1-July 1	Mar 1-July 15
Bermudagrass, Hybrid (Lawn Types)	Solid Sod	Anytime	Anytime	Anytime
Bermudagrass, Hybrid (Lawn Types)	Sprigs 1/sq ft	Mar 1-Aug 1	Mar 1-Aug 1	Feb 15-Sep 1
Fescue, Tall	40-50 lbs	Sep 1-Nov 1	Sep 1-Nov 1	--
Sericea	40-60 lbs	Mar 15-July 15	Mar 1-July 15	Feb 15-July 15
Sericea & Common Bermudagrass	40lbs 10 lbs	Mar 15-July 15	Mar 1-July 15	Feb 15-July 15
Switchgrass, Alamo	4 Lbs	Apr 1-Jun 15	Mar 15-Jun 15	Mar 15-Jun15

PLS means pure live seed and is used to adjust seeding rates. For example, to plant 10 lbs PLS of a species with germination of 80% and purity of 90%, $PLS = 0.8 \times 0.9 = 72\%$. $10 \text{ lbs PLS} = 10 / 0.72 = 13.9 \text{ lbs}$ of the species to be planted.

Seedbed Requirements

Establishment of vegetation should not be attempted on sites that are unsuitable due to compaction or inappropriate soil texture, poor drainage, concentrated overland flow, or steepness of slope until measures have been completed to correct these problems. To maintain a good stand of vegetation, the soil must meet certain minimum requirements as a growth medium. A good growth medium should have these attributes:

- Sufficient pore space to permit root penetration.
- Enough fine-grained soil material (silt and clay) to maintain adequate moisture and nutrient supply.
- Sufficient depth of soil to provide an adequate root zone. The depth to rock or impermeable layers such as hardpans should be 12" or more, except on slopes steeper than 2:1 where topsoiling is not feasible.
- A favorable pH range for plant growth, usually 6.0-6.5.

- Sufficient nutrients (nitrogen, phosphorus and potassium) for initial plant establishment.
- Freedom from large roots, branches, stones, or large clods. Clods and stones may be left on slopes steeper than 3:1 if they are to be hydroseeded.

If any of the above attributes are not met: i.e., if the existing soil is too dense, coarse, shallow or acidic to foster vegetation – chiseling, topsoil, or special amendments should be used to improve soil conditions. The soil conditioners described below may be beneficial or topsoil may be applied (for guidance on topsoiling see Topsoiling practice). These amendments should only be necessary where soils have limitations that make them poor for plant growth or for turf establishment.

- Peat-appropriate types are sphagnum moss peat, reed-sedge peat, or peat humus, all from fresh-water sources. Peat should be shredded and conditioned in storage piles for at least 6 months after excavation.
- Sand-should be clean and free of toxic materials.
- Vermiculite-use horticultural grade.
- Rotted manure-use stable or cattle manure not containing undue amounts of straw or other bedding materials.
- Thoroughly rotted sawdust-should be free of stones and debris. Add 6 lbs of nitrogen to each cubic yard.

Soil Amendments

Liming Materials

Lime (Agricultural limestone) should have a neutralizing value of not less than 90 percent calcium carbonate equivalent and 90 percent will pass through a 10 mesh sieve and 50 percent will pass through a 60 mesh sieve.

Selma chalk should have a neutralizing value of not less than 80 percent calcium carbonate equivalent and 90 percent will pass through a 10 mesh sieve.

Other liming materials that may be selected should be provided in amounts that provide equal value to the criteria listed for agricultural lime or be used in combination with agricultural limestone or Selma chalk to provide equivalent values to agricultural limestone.

Plant Nutrients

Commercial grade fertilizers that comply with current Alabama Fertilizer Laws should be used to supply nutrients required to establish vegetation.

Lime and fertilizer needs should be determined by soil tests. Soil testing is performed by the Auburn University Soil Testing Laboratory and provides recommendations based on field tests on Alabama soils. The local county Cooperative Extension Service can provide information on obtaining soil tests. Commercial laboratories that make recommendations based on soil analysis may be used.

When soil tests are not available, use the following rates for application of soil amendments.

Sandy soils: Use 1 ton/acre (exception on sandy soils – if the cover will be tall fescue and clover) use 2 tons/acre.

Clayey soils: 2 tons/acre.

(Do not apply lime to alkaline soils).

Grasses alone: Use 400 lbs/acre of 8-24-24 or the equivalent. Apply 30 lbs of additional nitrogen when grass has emerged and begun growth (approximately 0.8lbs/1000 ft²).

Grass-legume mixtures: Use 800 to 1200 lbs/acre of 5-10-10 or the equivalent.

Legumes Alone: Use 400 to 600 lbs/acre of 0-20-20 or the equivalent.

Note: Fertilizer can be blended to meet exact fertilizer recommendations. Take soil test recommendations to local fertilizer dealer for bulk fertilizer blends. This may be more economical than bagged fertilizer.

Application of Soil Amendments

Apply lime and fertilizer evenly and incorporate into the top 6” of soil by disking, chiseling or other suitable means during seedbed preparation. Operate machinery on the contour. On sites too steep for seedbed preparation, fertilizer and lime can be applied with a hydroseeder.

Seedbed Preparation

If needed, grade and shape to provide a surface on which equipment can safely and efficiently be used for seedbed preparation and seeding.

Install necessary sediment control practices before seedbed preparation and complete grading according to the approved plan.

Prepare a friable seedbed with tillage to a depth of at least 6”. Break up large clods, alleviate compaction, and smooth and firm the soil into a uniform surface. Fill in or level depressions that can collect water.

Planting Methods

Seeding

Use certified seed for permanent seeding whenever possible. Certified seed is inspected by the Alabama Crop Improvement Association to meet high quality standards and will be tagged with a “Certified Seed” tag. (Note: all seed sold in Alabama is required by law to be tagged to identify seed purity, germination, and

presence of weed seeds. Seed must meet state standards for content of noxious weeds.)

Seeding dates are determined using Figure PS-1 and Table PS-1.

Inoculate legume seed with the Rhizobium bacteria appropriate to the species of legume. Details of legume inoculation are located in Chapter 2 in the part on Vegetation for Erosion and Sediment Control under Inoculation of Legumes.

Plant seed uniformly with a cyclone seeder, a drill seeder, a cultipacker seeder, or by hand on a fresh, firm, friable seedbed. If the seedbed has been sealed by rainfall, it should be disked so the seed will be sown into a freshly prepared seedbed.

When using broadcast-seeding methods, subdivide the area into workable sections and determine the amount of seed needed for each section. Apply one-half the seed while moving back and forth across the area, making a uniform pattern; then apply the second half in the same way, but moving at right angles to the first pass.

Cover broadcast seed by raking or chain dragging; then firm the surface with a roller or cultipacker to provide good seed contact. Small grains should be planted no more than 1" deep and grasses and legume seed no more than 1/2" deep.

Hydroseeding

Surface roughening is particularly important when hydroseeding, as a roughened slope will provide some natural coverage for lime, fertilizer, and seed. The surface should not be compacted or smooth. Fine seedbed preparation is not necessary for hydroseeding operations; large clods, stones, and irregularities provide cavities in which seeds can lodge.

Mix seed, inoculant if required, and a seed carrier with water and apply as a slurry uniformly over the area to be treated. The seed carrier should be a cellulose fiber, natural wood fiber or other approved fiber mulch material which is dyed an appropriate color to facilitate uniform application of seed. Use the correct legume inoculant at 4 times the recommended rate when adding inoculant to a hydroseeder slurry. The mixture should be applied within one hour after mixing to reduce damage to seed.

Fertilizer should not be mixed with the seed-inoculant mixture because fertilizer salts may damage seed and reduce germination and seedling vigor.

Fertilizer may be applied with a hydroseeder as a separate operation after seedlings are established.

Lime is not normally applied with a hydraulic seeder because it is abrasive but if necessary it can be added to the seed slurry and applied at seeding or it may be applied with the fertilizer mixture. Also lime can be blown onto steeper slopes in dry form.

Sprigging

Hybrid bermudagrass cannot be grown from seed and must be planted vegetatively. Vegetative methods of establishing common and hybrid bermudagrass, centipedegrass and zoysia include sodding, plugging and sprigging (see Sodding practice).

When sprigs are planted with a sprigging machine, furrows should be 4-6" deep and 2 feet apart. Place sprigs no farther than 2 feet apart in the row and so that at least one rooting node is in the furrow.

When broadcasting is used for sprig planting, broadcast sprigs at the specified rate (Table PS-1). Press into the top ½" to 2" of soil with a cultipacker or with a disk set nearly straight so that the sprigs are not brought back to the surface. A mulch tacking machine may be used to press sprigs into the soil.

Mulching

The use of mulch provides instant cover and helps ensure establishment of vegetation under normal conditions and is essential to seeding success under harsh site conditions (see Mulching practice). Harsh site conditions include: slopes steeper than 3:1 and adverse soils (shallow, rocky, or high in clay or sand). Areas with concentrated flow should be treated differently and require sod, a hydromulch formulated for channels or an appropriate erosion control blanket.

Irrigation

Moisture is essential for seed germination and vegetation establishment. Supplemental irrigation can be very helpful in assuring adequate stands in dry seasons or to speed development of full cover. It is a requirement for establishment of vegetation from sod and sprigs and should be used elsewhere when feasible. However, irrigation is rarely critical for low-maintenance vegetation planted at the appropriate time of the year.

Water application rates must be carefully controlled to prevent runoff. Inadequate or excessive amounts of water can be more harmful than no supplemental water.

Maintenance

Generally, a stand of vegetation cannot be determined to be fully established until soil cover has been maintained for 1 full year from planting. Inspect vegetated areas for failure and make necessary repairs and vegetate as soon as possible.

If a stand has inadequate cover, reevaluate choice of plant materials and quantities of lime and fertilizer. Re-establish the stand after seedbed preparation or over-seed the stand. Consider a temporary seeding if the time of year is not appropriate for establishment of permanent vegetation (see Temporary Seeding practice).

If vegetation fails to grow, a soil test should be made to determine if soil acidity or nutrient imbalance is responsible.

To attain complete establishment, fertilization is usually required in the second growing season. Turf grasses require annual maintenance fertilization. Use soil tests if possible or follow the guidelines given for the specific seeding mixtures.

Protect vegetation during its establishing period from traffic that will be harmful. If appropriate, use either temporary fences or barriers to protect areas that may be damaged by excessive traffic.

Sediment Trap (ST)



Practice Description

A sediment trap is a temporary catch basin used for the purpose of intercepting and detaining small amounts of sediment to prevent it from leaving the construction site. This practice applies within disturbed areas with very small drainage basins that are subject to sheet erosion or in minor swales. Various materials may be used for sediment traps and include straw bales, sand bags, wattles, and various man-made materials and devices.

Planning Considerations

Note: Straw bales are the only sediment trap material covered in this handbook.

In certain situations, straw bales can be used as an alternative to silt fence for trapping sediment. The practice should only be used to trap sediment for a short duration from very small drainage areas. Straw bales comparatively low flow rate should be considered before choosing to use this practice. Ponding above the bales can occur rapidly due to the low flow rate. Overtopping and bypass of the bales can cause significant damage to the site. Additional measures should be used if turbidity leaving the site served by this practice is an issue.

Design Criteria

Drainage Area

For disturbed areas subject to sheet erosion the drainage area should be restricted to $\frac{1}{4}$ acre per 100 feet of trap. The slope length behind the trap should be restricted according to Table ST-1.

Table ST-1 Criteria for Straw or Hay Bale Placement

Land Slope (Percent)	Maximum Slope Length Above Bale (Feet)
<2	75
2 to 5	50
5 to 10	35
10 to 20	20
>20	10

Bale Size

Bales should be 14" x 18" x 36".

Anchors

Two 36" long (minimum) 2" x 2" hardwood stakes should be driven through each bale after the bales are properly entranced. Alternate anchors can be 2 pieces of no.4 steel rebar, 36" long (minimum). See Figure ST-1 for details on proper installation of straw bales.

Effective Life

Straw and hay bales have a relatively short period of usefulness and should not be used if the project duration is expected to exceed 3 months. Bale placement should result in the twine or cord being on the side and not the bottom of the bale.

Location

This practice should be used on nearly level ground and be placed at least 10 feet from the toe of any slope. The barrier should follow the land contour. The practice should never be used in live streams or in swales where there is a possibility of washout. The practice should also not be used in areas where rock or hard surfaces prevent the full and uniform anchoring of the bales.

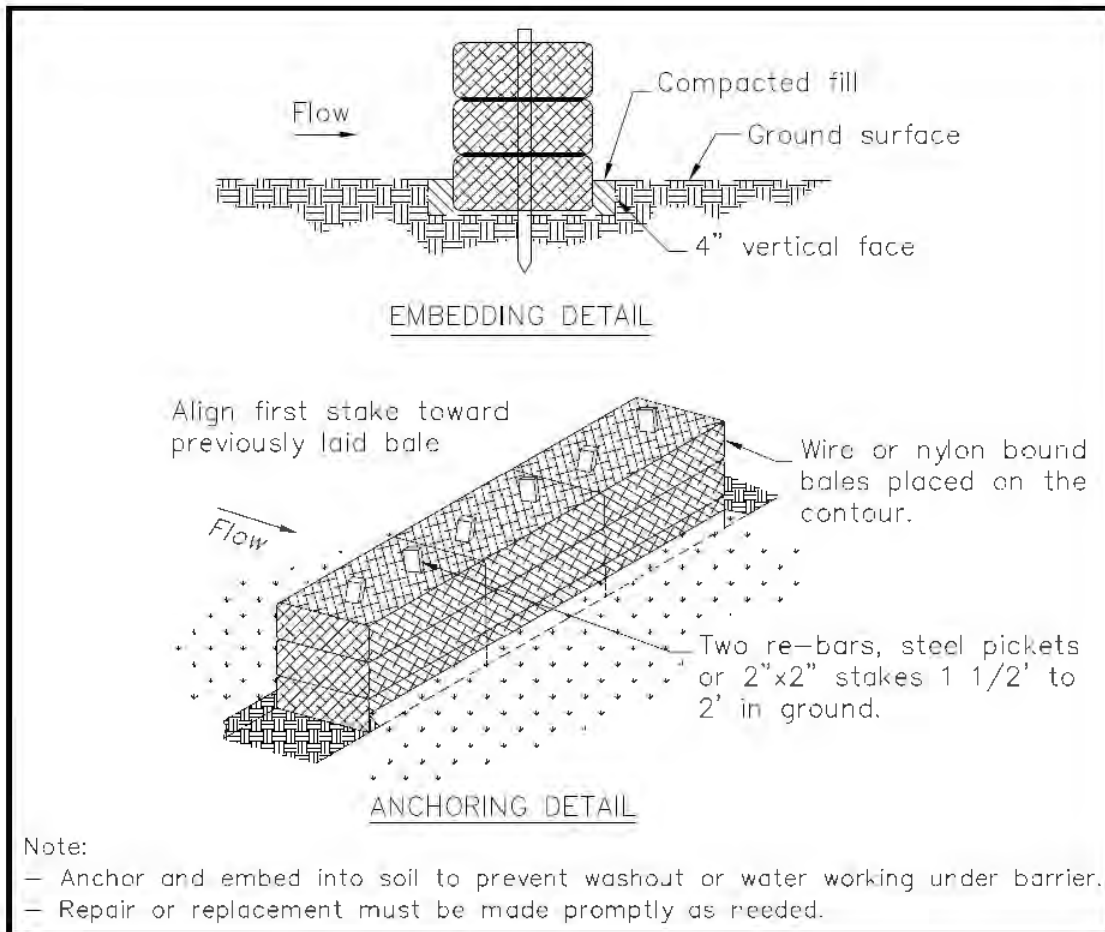

Figure ST-1 Anchoring Technique for Straw Bales

Sediment Barrier (SB)



Practice Description

A sediment barrier is a temporary structure used across a landscape mostly on the contour to reduce the quantity of sediment that is moving downslope. The most commonly used barrier is a silt fence (a geotextile fabric which is trenched into the ground and attached to supporting posts and possibly wire fence. Other barrier materials could include sand bags, wattles, and various man-made materials and devices that can be used in a similar manner as a silt fence.

This practice applies where sheet and rill erosion occurs on small disturbed areas. Barriers intercept runoff from upslope to form ponds that temporarily store runoff and allow sediment to settle out of the water and stay on the construction site.

Planning Considerations

Sediment barriers may be used on developing sites. It is most important that they be installed on the contour so that flow will not concentrate and cause bypassing by runoff going around the end of the barrier or overtopping because of lack of storage capacity.

The most commonly used sediment barriers are silt fences, and manufactured sediment logs (often referred to as wattles or sediment retention fiber roll). Manufactured sediment logs should be installed according to manufacturer's recommendations.

The success of silt fences depends on a proper installation (on the contour with each end turned up slope) that causes the fence to develop maximum efficiency

of sediment trapping. Silt fences should be carefully installed to meet the intended purpose.

A silt fence is specifically designed to retain sediment transported by sheet flow from disturbed areas, while allowing water to pass through the fence. Silt fences should be installed to be stable under the flows expected from the site. Silt fences should not be installed across streams, ditches, waterways, or other concentrated flow areas.

Silt fences are composed of geotextile supported between steel or wooden posts. Silt fences are commercially available with geotextile attached to the post and can be rolled out and installed by driving the post into the ground. This type of silt fence is simple to install, but more expensive than some other installations. Silt fences must be trenched in at the bottom to prevent runoff from undermining the fence and developing rills under the fence. Locations with high runoff flows or velocities should use wire fence reinforcement.

A rather recent innovation that somewhat resembles a double silt fence and referred to as a “sediment retention barrier with flocculant” is used to reduce turbidity in the runoff that will reach sensitive sites. The measure consists of a double row of netting or high flow silt fences installed parallel with loose straw, woodchips or other organic fill spread between the rows and straw or other organic material laid on the ground adjacent to the downslope row (see following picture). An approved flocculant powder is added to the material between the rows and to the organic material below the downslope row prior to runoff events. The measure is located upstream of a filter strip or buffer zone and is installed on the contour. Design professionals should get details needed to design this measure from a qualified industry representative.



Sediment retention barriers may be used as a “last line of defense” against sediment leaving the construction site in sensitive areas. Do not use it in lieu of adequate erosion and sediment control practices.

Design Criteria (only for silt fence)

Silt fence installations are normally limited to situations in which only sheet or overland flow is expected because the practice cannot pass the volumes of water generated by channel flows. Silt fences are normally constructed of synthetic fabric (geotextile) and the life is expected to be the duration of most construction projects. Silt fence fabric should conform to the requirements of geotextile meeting the requirements found in ASSHTO M288.

The drainage area behind the silt fence should not exceed $\frac{1}{4}$ acre per 100 linear feet of silt fence for non-reinforced fence and $\frac{1}{2}$ acre per 100 feet of wire reinforced fence. When all runoff from the drainage area is to be stored behind the fence (i.e. there is no stormwater disposal system in place) the maximum slope length behind the fence should not exceed those shown in Table SB-1.

Table SB-1 Slope Limitations for Silt Fence

Land Slope (Percent)	Maximum Slope Length Above Fence (Feet)
<2	100
2 to 5	75
5 to 10	50
10 to 20*	25
>20	15

*In areas where the slope is greater than 10%, a flat area length of 10 feet between the toe of the slope to the fence should be provided.

Type A Silt Fence

Type A fence is at least 32" above ground with wire reinforcements and is used on sites needing the highest degree of protection by a silt fence. The wire reinforcement is necessary because this type of silt fence is used for the highest flow situations and has almost 3 times the flow rate as Type B silt fence. Type A silt fence should be used where runoff flows or velocities are particularly high or where slopes exceed a vertical height of 10 feet. Staked tie backs on each end of a Type A silt fence may be necessary to prevent overturning.

Provide a riprap splash pad or other outlet protection device for any point where flow may overtop the sediment fence.

The silt fence should be installed as shown in Figure SB-1. Materials for posts and fasteners are shown in Tables SB-2 and SB-3. Details for overlap of Type A silt fence is available from The Alabama Department of Transportation construction drawings.

Table SB-2 Post Size for Silt Fence

	Minimum Length	Type of Post	Size of Post
Type A	5'	Steel "T" Post	1.3lb./ft. min.
Type B	4'	Soft Wood Oak Steel	3" diameter or 2X4 1.5" X 1.5" 1.3lb./ft. min.
Type C	3'	Soft Wood Oak Steel	2" diameter or 2X2 1" X 1" .75lb./ft. min.

Table SB-3 Wood Post Fasteners for Silt Fence

	Gauge	Crown	Legs	Staples/Post
Wire Staples	17 min.	¾" wide	½" long	5 min.
	Gauge	Length	Button Heads	Nail/Post
Nails	14 min.	1"	¾" long	4 min.

Type B Silt Fence

This 36" wide filter fabric should be used on developments where the life of the project is greater than or equal to 6 months.

The silt fence should be installed as shown in Figure SB-2. Materials for posts and fasteners are shown in Tables SB-2 and SB-3. Details for overlap of the silt fence and fastener placement are shown in Figure SB-4.

Type C Silt Fence

Though only 22" wide, this filter fabric allows the same flow rate as Type B silt fence. Type C silt fence should be limited to use on relatively minor projects, such as residential home sites or small commercial developments where permanent stabilization will be achieved in less than 6 months.

The silt fence should be installed as shown in Figure SB-3. Materials for posts and fasteners are shown in Tables SB-2 and SB-3. Details for overlap of the silt fence and fastener placement are shown in Figure SB-4.

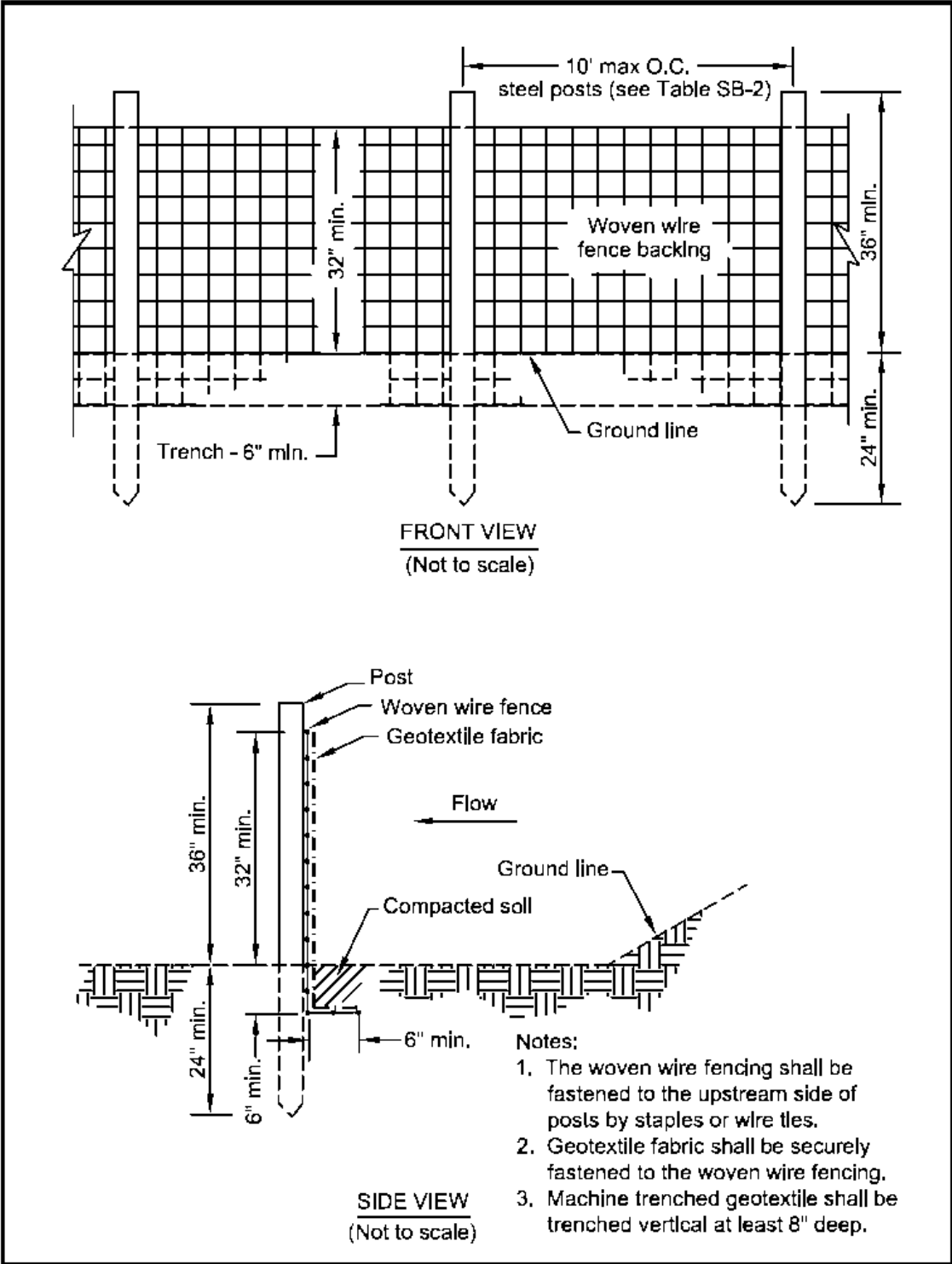

Figure SB-1 Silt Fence-Type A
(For post material requirements see Tables SB-2 and SB-3)

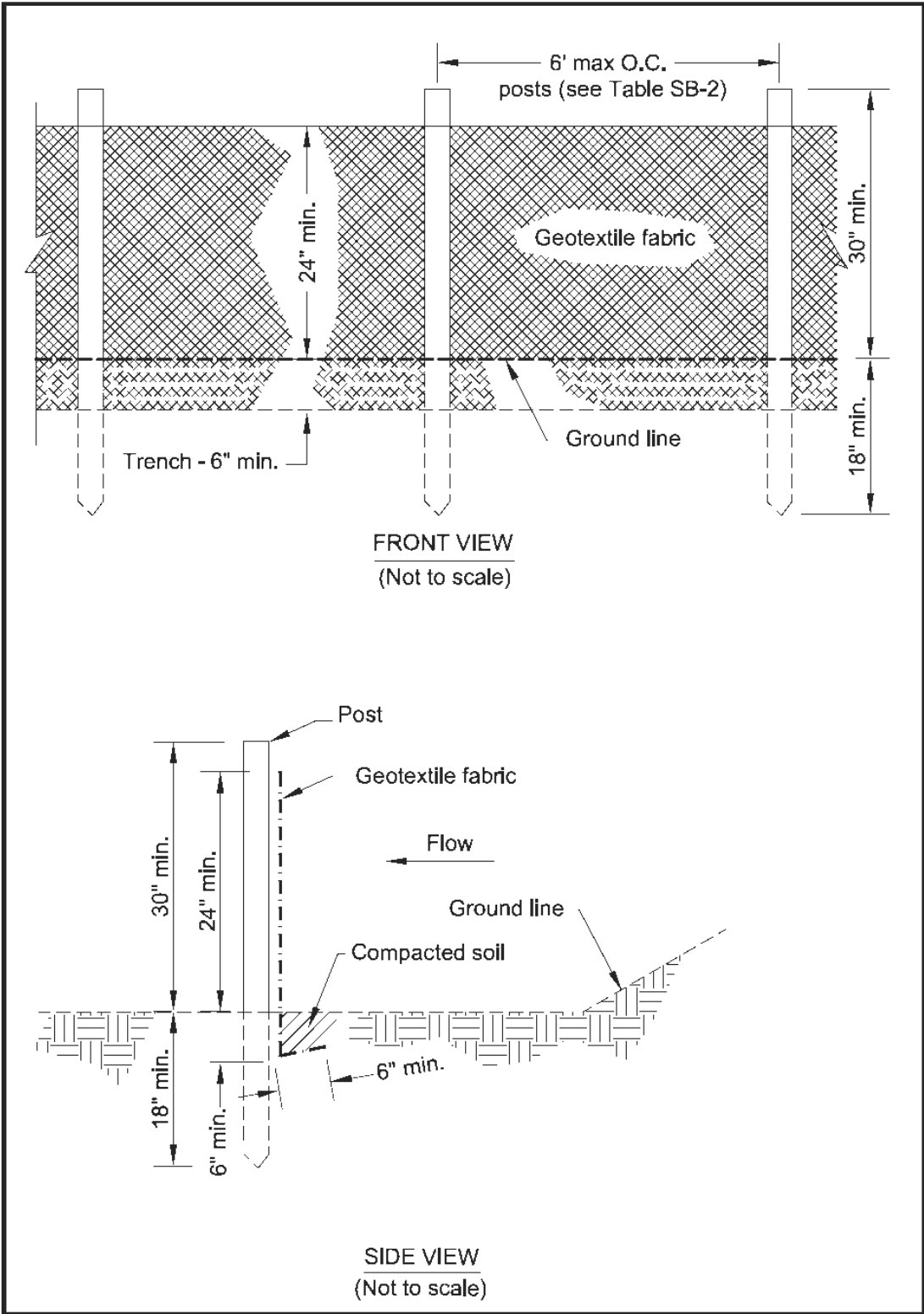

Figure SB-2 Silt Fence - Type B
(1) For post material requirements see Tables SB-2 and SB-3

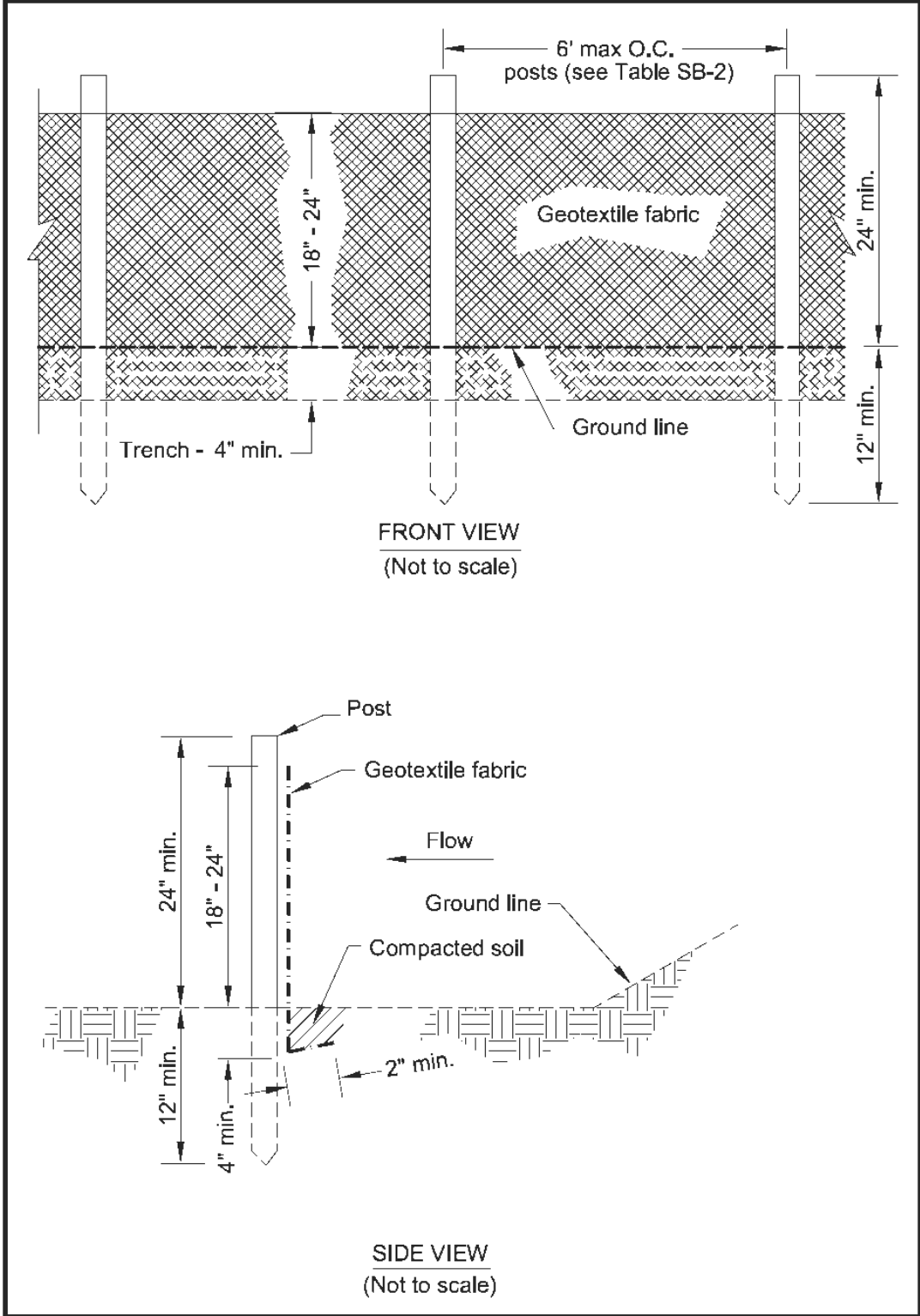

Figure SB-3 Silt Fence – Type C
(1) For post material requirements see Tables SB-2 and SB-3

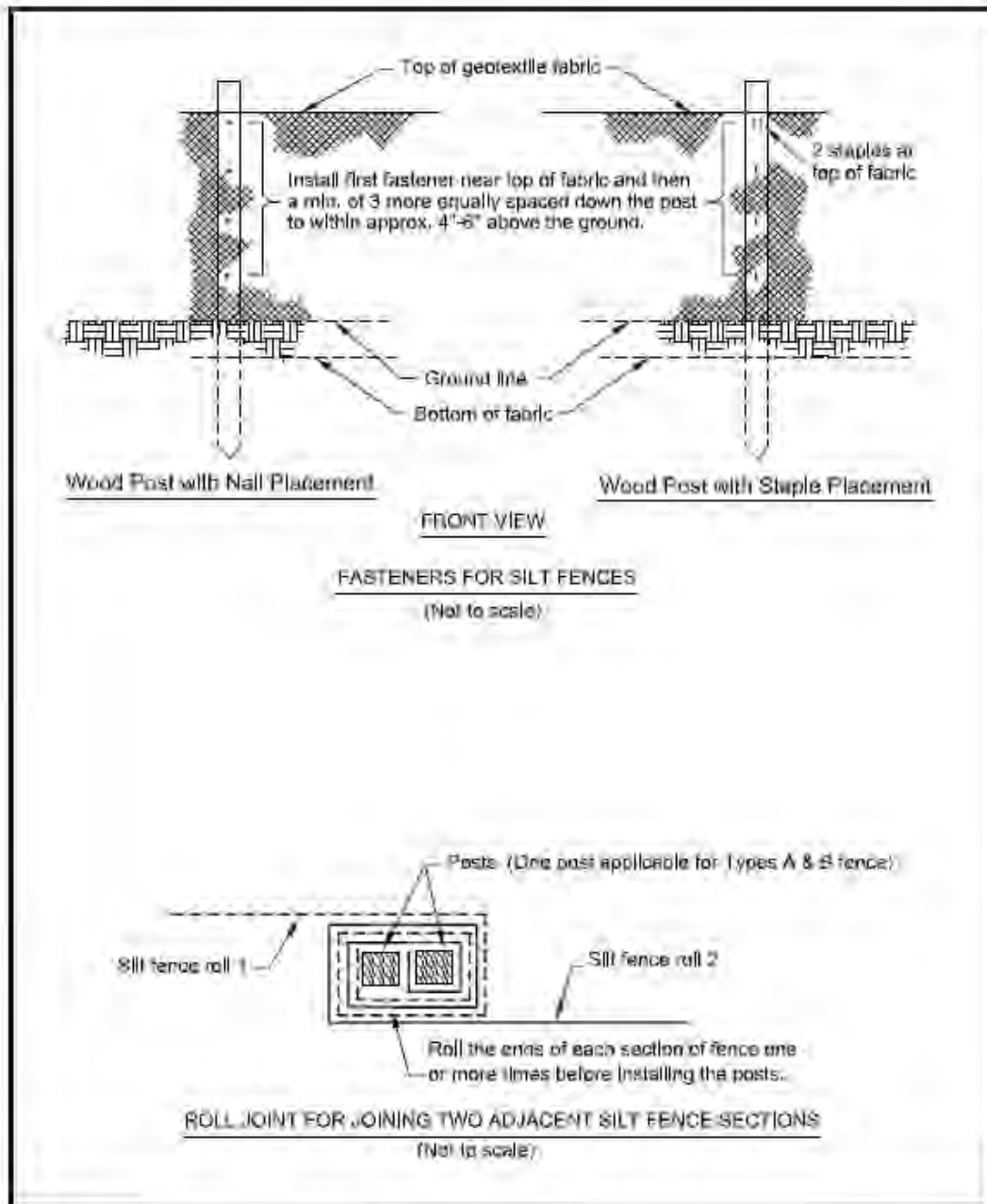

Figure SB-4 Silt Fence Installation Details

Stormwater Detention Basin (SDB)



Practice Description

A stormwater detention basin is a dam-basin practice designed to hold stormwater runoff and release the water slowly to prevent downstream flooding and stream erosion. The practice is an extremely effective water quality and peak discharge reduction measure. Its usage is best suited to larger, more intensively developed sites. Structure life is 10 years or more. A stormwater detention basin can have a permanent pool of water or be designed to have a dry basin (typical). A detention basin can be designed to also serve as a sediment basin during the construction period.

Planning Considerations

The purpose of a stormwater detention basin is to intercept stormwater runoff and to protect drainageways, properties, and right-of-ways downstream of the structure. A qualified design professional engineer with expertise in hydrology and hydraulics should always design stormwater detention basins. This practice applies only to permanent basins on sites where:

- Failure of the dam will not result in loss of life; in damage to homes, commercial, or industrial buildings, main highways, or railroads; or in interruption of the use or service of public utilities.
- The peak release rate of stormwater runoff from the design storm does not exceed the predevelopment runoff rate for the drainage area or the rate allowed by local ordinances, whichever is less.

- The drainage area does not exceed 50 acres. The peak flow through the principal spillway normally should not exceed 50 cfs. Structures should be designed as water impoundment structures utilizing inflow hydrographs, storage characteristics of the basin, and outflow hydrographs in the design process. Design criteria should be commensurate with the complexity of site conditions, including consideration of damages that would be caused by breaching of the embankment by overtopping.

A stormwater detention basin is appropriate where physical site conditions or land ownership restrictions preclude the installation of other stormwater measures to adequately control runoff. Where site conditions are suitable, low impact practices should be strongly considered to reduce the volume of stormwater runoff. The basin should be maintained throughout the life of the development which produced the need for the basin.

Design Criteria

Classification

Table SDB-1 shows the recommended design and classification criteria for three types of Stormwater Detention Basins.

Table SDB-1 Stormwater Detention Basin Classification

Type ¹	Max. W/S Size (acre)	Max. Dam Ht. ² (feet)	Minimum Principal Spillway Design Storm Frequency ³	Minimum Emergency Spillway Design Storm Frequency ³	Freeboard ⁴ (feet)
1	20	7	5-yr 24-hr	10-yr 24-hr	1.0
2	20	10	5-yr 24-hr	10-yr 24-hr	1.0
3	50	15	10-yr 24-hr	25-yr 24-hr	1.0

¹ Type 1 basins may be used where site conditions prevent the construction of an emergency spillway on residual earth.

² Height is measured from the top of the dam to the low point on the original centerline survey of the dam.

³ Runoff should be determined by NRCS methods or other methods accepted by local ordinances. Soil and cover conditions used should be based on those expected during the construction period.

⁴ Vertical distance between basin water surface at maximum flow through the emergency spillway and top of dam.

Location

Locate the stormwater detention basin to obtain the maximum storage benefit from the terrain and for ease of cleanout of trapped sediment. It should be located to minimize interference with construction activities and construction of utilities. Whenever possible, locate detention basins out of floodplain areas and never in flowing streams. Detention basins can be an excavated basin type as well as an earthfill dam type or a combination of the two.

Entrance of Runoff into Basin

Protect the entrance points of surface runoff into the basins to prevent erosion of the basin walls. Install riprap check dams, grade stabilization structures, or other water control devices at main points of inflow to ensure direction of runoff and protect the points of entry into the basin. Locate points of entry so as to ensure maximum travel distance of runoff water through the basin to the point of exit from the basin.

Erosion and Sedimentation Control

Conduct construction operations in such a manner that erosion and sedimentation will be minimized. Comply with state and local laws concerning pollution abatement.

Safety

Stormwater detention basins should comply with any state laws related to Dam Safety.

Stormwater detention basins are attractive to children and can be very dangerous. Local ordinances and regulations must be adhered to regarding health and safety. The developer or owner should check with local building officials on applicable safety requirements. If fencing of basins is required, the location of and type of fence should be shown on the plans.

Storage

The minimum capacity of a stormwater detention basin below the crest of the principal spillway pipe should be $\frac{1}{2}$ inch per acre of the potential disturbed portion of the drainage area plus the runoff volume from a 2-year frequency, 24-hour duration storm for the developed conditions.

Shape of the Basin

Design the stormwater detention basin to have a flow length to width ratio of 2:1 or greater, where flow length is the distance between the point of inflow and the point of outflow.

When the basin is used as for sediment control during construction, design the sediment storage portion of the basin to meet the requirements in the *Sediment Basin* practice.

Principal (Pipe) Spillway Design

Layout

The spillway should consist of a vertical riser joined at its bottom to a conduit (barrel) which extends through the embankment. Connections should be watertight.

Capacity

The maximum capacity of the pipe spillway should not exceed the peak rate of runoff from the drainage area in its pre-developed condition for all rainfall events up to and including the principal spillway design storm frequency. The minimum inside diameter of the barrel should be 8 inches. The diameter of the vertical inlet riser should be a minimum of 1.5 times greater than that of the barrel to ensure full barrel flow. Size the pipe to remove at least 50% of the runoff volume of the design storm within a 3 day period.

Inlet Data

The vertical inlet (riser) may be one of the following:

- A full round pipe.
- A half round pipe fitted for flashboards.
- A box-type riser fitted with flashboards.

Set the crest of the riser inlet at an elevation to provide the minimum storage requirement (runoff from a 2-year 24-hour storm for developed conditions and ½” sediment storage for the disturbed acreage). The riser should have a base (ballast) of sufficient weight to provide a 1.5:1 safety factor against flotation. Install an approved trash rack and anti-vortex device securely on top of the riser.

Anti-seep Collars

Install anti-seep collars around all conduits through earth fills according to the following criteria:

- Collars should be placed to increase the seepage length along the conduit by a minimum of 15 percent of the pipe length located within the saturation zone.
- Collar spacing should be between 5 and 14 times the vertical projection of each collar.
- All collars should be placed within the saturation zone.
- All anti-seep collars and their connection should be watertight.

A properly designed drainage diaphragm may be utilized in lieu of anti-seep collars.

Outlet

Provide protection of the barrel pipe outlet where needed to prevent outlet scour. Design outlet protection measures according to the *Outlet Protection Standard*.

Dewatering the Basin

Stormwater detention basins can serve a dual purpose as a sediment basin during construction and a stormwater detention basin after construction (See Figure SDB-1). Basins that serve only for the purpose of stormwater detention can be designed as either a dry pool (typical) or a wet pool (See Figures SDB-2 and SDB-3).

For basins designed to also serve as a sediment basin, dewatering the sediment basin volume ($\frac{1}{2}$ " runoff for the disturbed acreage plus $\frac{1}{2}$ " runoff for the total drainage area) is best accomplished with a skimmer designed according to the *Sediment Basin* practice design criteria. Dewatering of the 2-year developed condition runoff above the sediment basin volume can be accomplished with a small 4 inch orifice (installed with trash protection) in the riser at the sediment storage elevation. After disturbed areas contributing runoff water to the basin have been stabilized, the skimmer dewatering device can be removed to allow the basin to operate only as a stormwater detention basin. If the purpose of the basin is to also treat the "first flush", the skimmer can be left as a permanent treatment measure. Any accumulation of sediments that would reduce stormwater detention storage should be removed and disposed of in a proper manner.

Dry basins that serve only as stormwater detention can be dewatered with a 4" orifice at the base of the riser.

Emergency spillways

Layout

Install earth emergency spillways for Type 2 and 3 basins only in undisturbed earth. Emergency spillways for Type 1 basins may be located on compacted earth fill selected for erosion resistance qualities. Other erosion control measures such as rock riprap may be required to ensure stable emergency spillways. Each spillway should have a longitudinal level section at least 25 feet long at its crest and a straight outlet section for at least 25 feet or $\frac{1}{2}$ the base width of the embankment fill.

Capacity and Design

Spillways should be trapezoidal in cross section with minimum bottom widths of 10 feet and side slopes of 3:1. The elevation of the emergency spillway crest will be determined through routing procedures of the principal spillway design storm.

The capacity of the emergency spillway should be adequate to pass peak discharges of the emergency spillway design storm, taking into account the discharge through the principal spillway and the available storage. As a minimum, the designer should consider at least 0.5 foot of stage for flow through the emergency spillway. Spillways should be designed to pass designed discharges at non-erosive velocities for the types of protection used.

Embankment

The minimum top width should be 8 feet. Side slopes should be no steeper than 2½:1 (mowable surfaces should be 3:1 or flatter). On sites where relatively impermeable material (clay) is not available for a core, the downstream side slope should be increased to 4:1. Construct a keyway along the centerline of the dam. It should be at least 8 feet wide, have 1:5:1 or flatter side slopes, and should extend at least 2 feet below the normal ground surface. The core of the embankment should be at least 8 feet wide and consist of the most impermeable material available at the site. Extend this core from the bottom of the keyway to the crest of the emergency spillway.

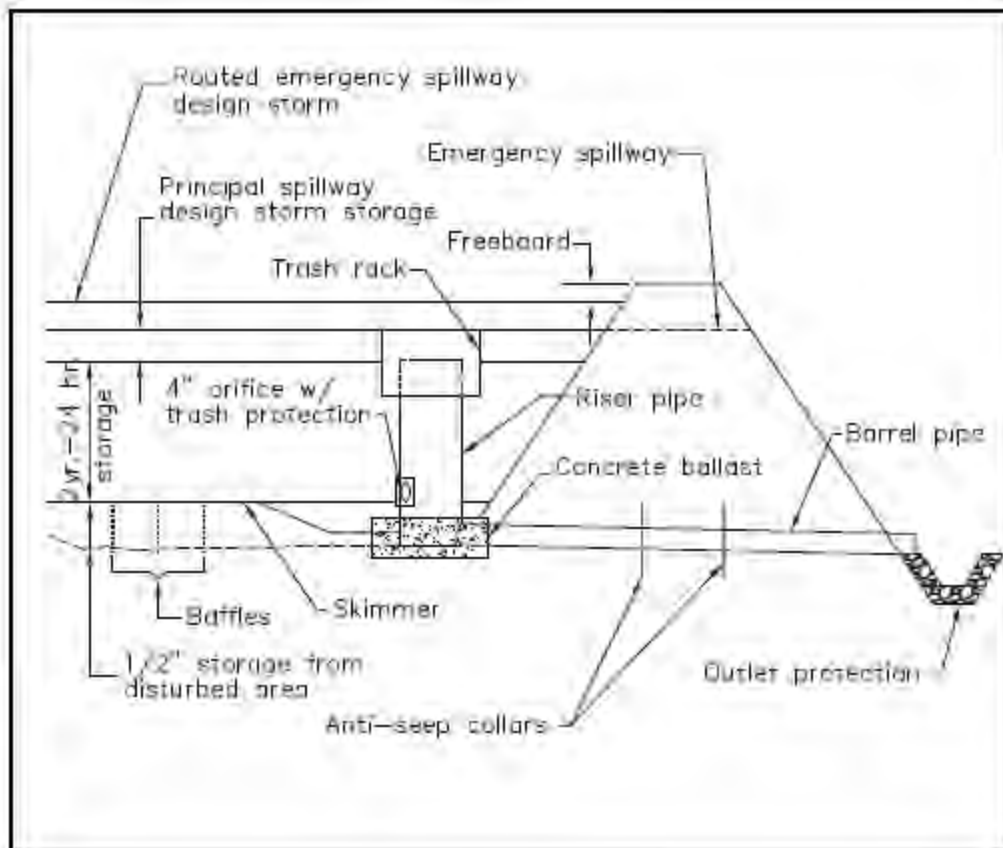

Figure SDB-1 Typical Stormwater Detention Basin / Sediment Basin Components.

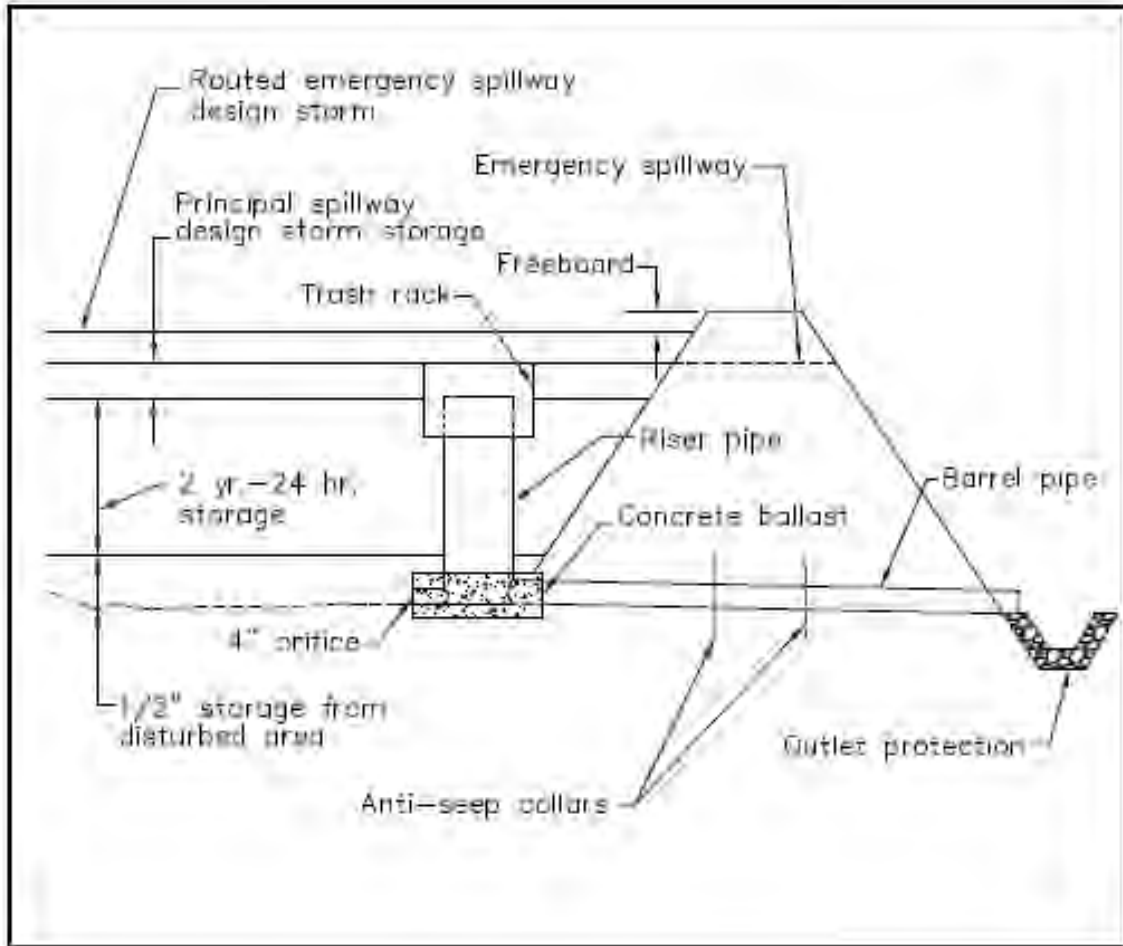

Figure SDB-2 Typical Dry Stormwater Detention Basin Components.

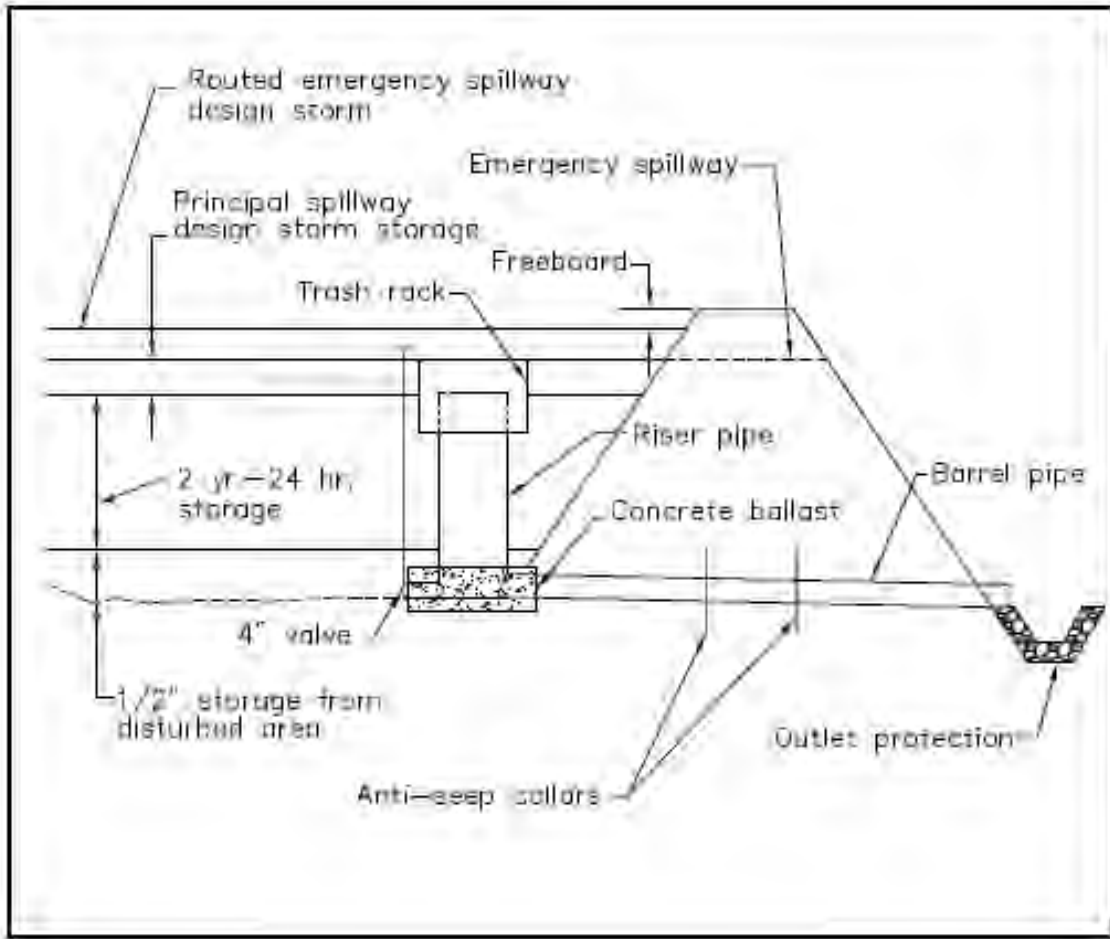

Figure SDB-3 Typical Wet Stormwater Detention Basin Components.

Sediment Basin (SBN)



Practice Description

An earthen embankment suitably located to capture runoff, with an emergency spillway lined to prevent spillway erosion, interior porous baffles to reduce turbulence and evenly distribute flows, and equipped with a floating skimmer or other approved surface dewatering device that removes water from the top of the basin. Flocculants are commonly used with a sediment basin to increase sediment capture.

Planning Considerations

Sediment basins are needed where drainage areas are too large for other sediment control practices.

Select locations for basins during initial site evaluation. Locate basin so that sudden failure should not cause loss of life or serious property damage. Install sediment basins before any site grading takes place within the drainage area.

Select sediment basin sites to capture sediment from all areas that are not treated adequately by other sediment control measures. Always consider access for cleanout and disposal of the trapped sediment. Locations where a pond can be

formed by constructing a low dam across a natural swale are generally preferred to sites that require excavation. Where practical, divert sediment-free runoff away from the basin.

Because the emergency spillway is actually used relatively frequently, it is generally stabilized using geotextile and riprap that can withstand the expected flows without erosive velocities. The spillway should be placed as far from the inlet of the basin as possible to maximize sedimentation before discharge. The spillway should be located in natural ground (not over the embankment) to the greatest extent possible.

The use of approved flocculants properly introduced into the turbid runoff water at the inlet of the basin and/or at the first baffle should be considered to help polish the discharge from the basin for meeting turbidity requirements.

A fore bay or sump area prior to the basin should be considered for capture of heavier particles.

Baffles

Porous baffles effectively spread the flow across the entire width of a sediment basin or trap and cause increased deposition within the basin. Water flows through the baffle material, but is slowed sufficiently to back up the flow, causing it to spread across the entire width of the baffle (Figure SBN-1). Spreading the flow in this manner utilizes the full cross section of the basin and reduces turbulence which shortens the time required for sediment to be deposited.

The installation should be similar to a sediment barrier (silt fence) (Figure SBN-2) utilizing posts and wire backing. The most proven material for a baffle is 700 - 900 g/m² coir erosion blanket (See following picture). Other materials proven by research to be equivalent in this application may be used. A support wire or rope across the top will help prevent excessive sagging if the material is attached to it with appropriate ties. Another option is to use a sawhorse type of support with the legs stabilized with rebar inserted into the basin floor. These structures work well and can be prefabricated off site and quickly installed.

Baffles need to be installed correctly in order to fully provide their benefits. Refer to Figure SBN-2 and the following key points:

- The baffle material needs to be secured at the bottom and sides by using staples or stakes, trenching, or securing horizontally to the bottom. Flow should not be allowed under the baffle.
- Most of the sediment will accumulate in the first bay, so this should be readily accessible for maintenance.

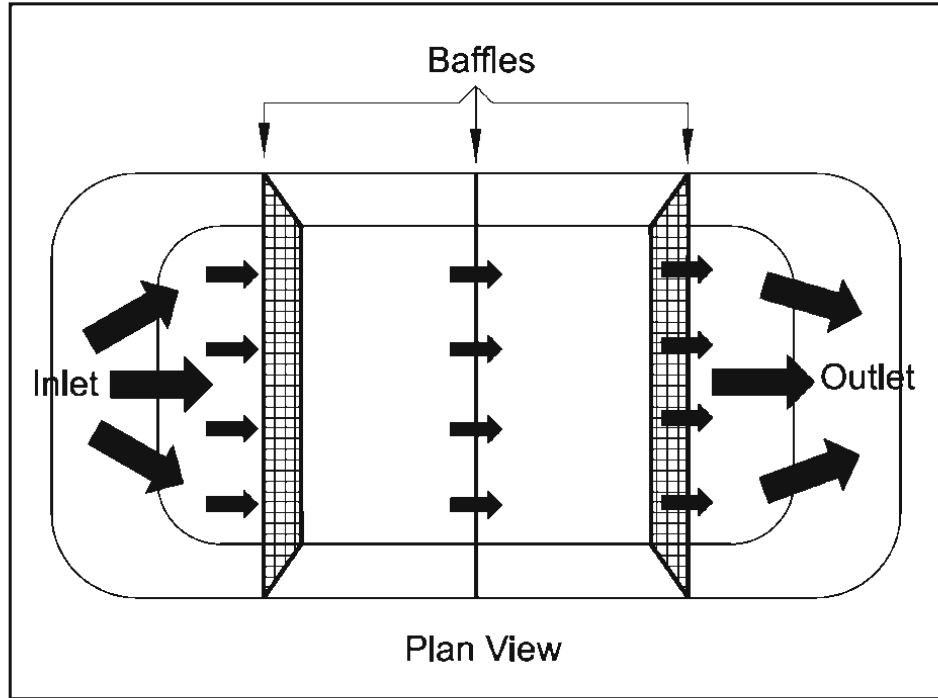

Figure SBN-1 Porous baffle in a sediment basin
 (from North Carolina Erosion and Sediment Control Planning and Design Manual.)

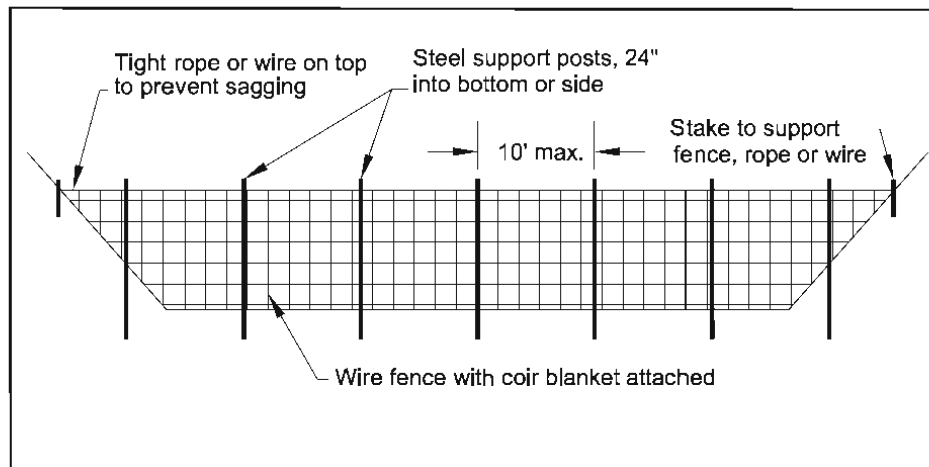

Figure SBN-2 Cross-section of a porous baffle in a sediment basin
 Note there is no weir because the water flows through the baffle material
 (from North Carolina Erosion and Sediment Control Planning and Design Manual.)



Example of porous baffle made of 700 g/m² coir erosion blanket as viewed from the inlet

Basin Dewatering

Sediment basins should be dewatered from the surface. A device often used for this is a skimmer that withdraws water from the basin's water surface, thus removing the highest quality water for delivery to the uncontrolled environment. One type of skimmer is shown in Figure SBN-3. By properly sizing the skimmer's control orifice, the skimmer can be made to dewater a design hydrologic event in a prescribed period.

An advantage of the skimmer is that it can be reused on future projects. Skimmers are generally maintenance free, but may require occasional maintenance to remove debris from the orifice.

All basin dewatering devices must dewater the basin from the top of the water surface. The rate of dewatering must be controlled. A dewatering time of 48 to 120 hours (2 to 5 days) is required for the basin to function properly.

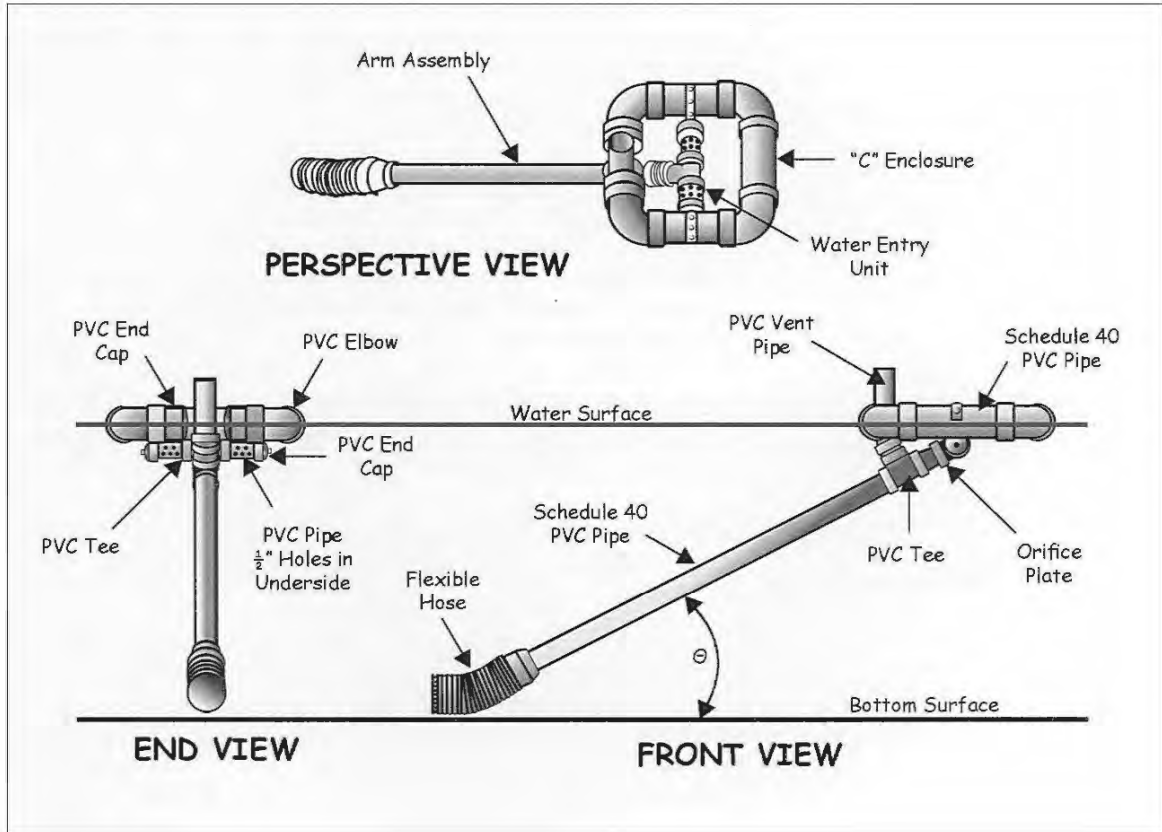

Figure SBN-3 Schematic of a skimmer
 (from Pennsylvania Erosion and Sediment Pollution Control Manual, March, 2000)

Design Criteria

Summary:	Temporary Sediment Trap
Emergency Spillway:	Trapezoidal spillway with non-erosive lining. 10 – year, 24 – hour rainfall event
Recommended Maximum Drainage Area:	10 acres
Minimum Volume:	3,600 cubic feet per acre of drainage area
Minimum L/W Ratio:	2:1
Minimum Depth:	2 feet
Dewatering Mechanism:	Skimmer(s) or other approved basin dewatering device.
Dewatering Time:	2 – 5 days
Baffles Required:	3

Compliance with Laws and Regulations

Design and construction should comply with state and local laws, ordinances, rules and regulations.

Design Basin Life

Structures intended for more than 3 years of use should be designed as permanent structures. Procedures outlined in this section do not apply to permanent structures.

Dam Height

In order to ensure public safety, the maximum dam height should be 10 feet, measured from the designed (settled) top elevation of the dam to the lowest point at the downstream toe.

Drainage Area

In order to minimize risk to the public and environment, the maximum drainage area for each sediment basin should be minimized. The recommended maximum drainage area is 10 acres. The absolute maximum drainage area should be 100 acres.

Basin Locations

Select areas that:

- Are not intermittent or perennial streams
- Allow a maximum amount of construction runoff to be brought into the structure
- Provide capacity for storage of sediment from as much of the planned disturbed area as practical
- Exclude runoff from undisturbed areas where practical
- Provide access for sediment removal throughout the life of the project
- Interfere minimally with construction activities

Basin Shape

Ensure that the flow length to basin width ratio is 2:1 or larger to improve trapping efficiency. Length is measured at the elevation associated with the minimum storage volume. Generally, the bottom of the basin should be level to ensure the baffles function properly. The area between the inlet and first baffle can be designed with reverse grade to improve the trapping efficiency.

Research has shown that the surface area of the basin should be maximized to improve trapping efficiency. Results of tests show that a surface area of 435 sq. ft. per CFS (peak discharge for the 10-year, 24-hour event), is needed for effective trapping efficiency.

Storage Volume

Ensure that the sediment storage volume of the basin is at least 3,600 cubic feet per acre for the area draining into the basin. Volume is measured below the emergency spillway crest. Remove sediment from the basin when approximately one-half of the storage volume has been filled.

Baffles

Space the baffles to create equal zones of volume within the basin.

The top of the baffle should be the same elevation as the maximum water depth flowing through the emergency spillway. Baffles are most effective at a height of 3 feet; however, site conditions may warrant taller baffles.

Baffles should be designed to go up the sides of the basin banks so water does not flow around the baffles. Most of the sediment will be captured in the inlet zone. Smaller particle size sediments are captured in the latter cells.

The design life of the fabric can be up to 3 years, but may need to be replaced more often if damaged or clogged.

Spillway Capacity

The emergency spillway system must carry the peak runoff from the 10-year 24-hour storm with a minimum 1 foot of freeboard (distance between the surface of the water with the spillway flowing full and the top of the embankment). Base runoff computations on the most severe soil cover conditions expected in the drainage area during the effective life of the structure.

Sediment Cleanout Elevation

Determine the elevation at which the invert of the basin would be half-full. This elevation should also be marked in the field with a permanent stake set at this ground elevation (not the top of the stake).

Basin Dewatering

The basin should be provided with a surface outlet. A floating skimmer should be attached to a Schedule 40 PVC barrel pipe of the same diameter as the skimmer arm. The skimmer apparatus will control the rate of dewatering. The skimmer should be sized to dewater the basin in 48-120 hours (2-5 days). The barrel pipe should be located under the embankment with at least one anti-seep collar at the center of the embankment projecting a minimum of 1.5 ft in all directions from the pipe. A drainage diaphragm can be used in lieu of an anti-seep collar. The barrel pipe outlet must be stable and not cause erosion.

*Skimmer Orifice Diameter***Skimmer Selection Procedure**

The manufacturer's skimmer performance charts are recommended for use in selecting skimmers for use in dewatering sediment control basins. Always verify performance with the manufacturer's information.

Required input data:

Basin volume = _____ ft³

Desired dewatering time = _____ days

Procedure:

1. First use the basin volume (ft³) and the desired dewatering time (days) and determine the required skimmer outflow rate in cubic feet per day (ft³/d) from the following equation

$$Q = \frac{V}{t_d}$$

2. Scan the manufacturer's skimmer performance charts and select the (a) skimmer size and (b) the skimmer orifice diameter (in inches) if desired.

Example: Select a skimmer that will dewater a 20,000 ft³ sediment basin in 3 days.

Solution: First compute the required outflow rate as

$$Q = \frac{V}{t_d} = \frac{20000 \text{ ft}^3}{3d} = 6670 \text{ ft}^3 / d$$

Now go to the manufacturer's selection charts and select an appropriate skimmer. For example, a 2-inch skimmer with no orifice could have an outflow rate of 5,429 ft³/d, which will require about 3.5 days to dewater the basin. A 4-inch skimmer with a 2.5 inch diameter orifice could have an outflow rate of 8,181 ft³/d and dewater the basin in about 2.5 days.

Example: A More Precise Alternative: Most skimmers come with a plastic plug that can be drilled forming a hole that will limit the skimmer's outflow to any desired rate. Thus, for a specific skimmer the orifice that will dewater a basin in a more precisely chosen time can be determined. The flow through an orifice can be computed as

$$Q = CA\sqrt{2gH}$$

where C is the orifice coefficient (usually taken to be 0.6), A is the orifice cross-sectional area in ft², g is the acceleration of gravity (32.2 ft/sec²), and H is the driving head on the orifice center in feet. The orifice equation can be simplified to yield the orifice flow in gpm using the diameter D (in inches) and the head in feet as

$$Q = 12D^2\sqrt{H}$$

Or the orifice flow in ft³/d using the diameter D (in inches) and the head in feet as

$$Q = 2310D^2\sqrt{H}$$

If we solve the orifice equation for the orifice diameter using the desired outflow rate (6670 ft³/d) and the head driving water through the skimmer (0.333 ft for a 4-inch skimmer) as

$$D = \sqrt{\frac{Q}{2310\sqrt{H}}} = \sqrt{\frac{6670}{2310\sqrt{0.333}}} = 2.24 \text{ inches}$$

We see that if the plastic plug were drilled to a diameter of 2.24 inches and placed in a 4-inch skimmer, the dewater rate would be 6,670 ft³/d and the 20,000 ft³ basin would dewater in 3 days.

Outlet Protection

Provide outlet protection to ensure erosion does not occur at the pipe outlet.

Basin Emergency Spillway

The emergency spillway should carry the peak runoff from a 10-year storm. The spillway should have a minimum 10 foot bottom width, 0.5 foot flow depth, and 1 foot freeboard above the design water surface.

Construct the entire flow area of the spillway in undisturbed soil to the greatest extent possible. Cross section should be trapezoidal, with side slopes 3:1 or flatter for grass spillways (Figure SBN-4) and 2:1 for riprap. Select vegetated lining to meet flow requirements and site conditions.

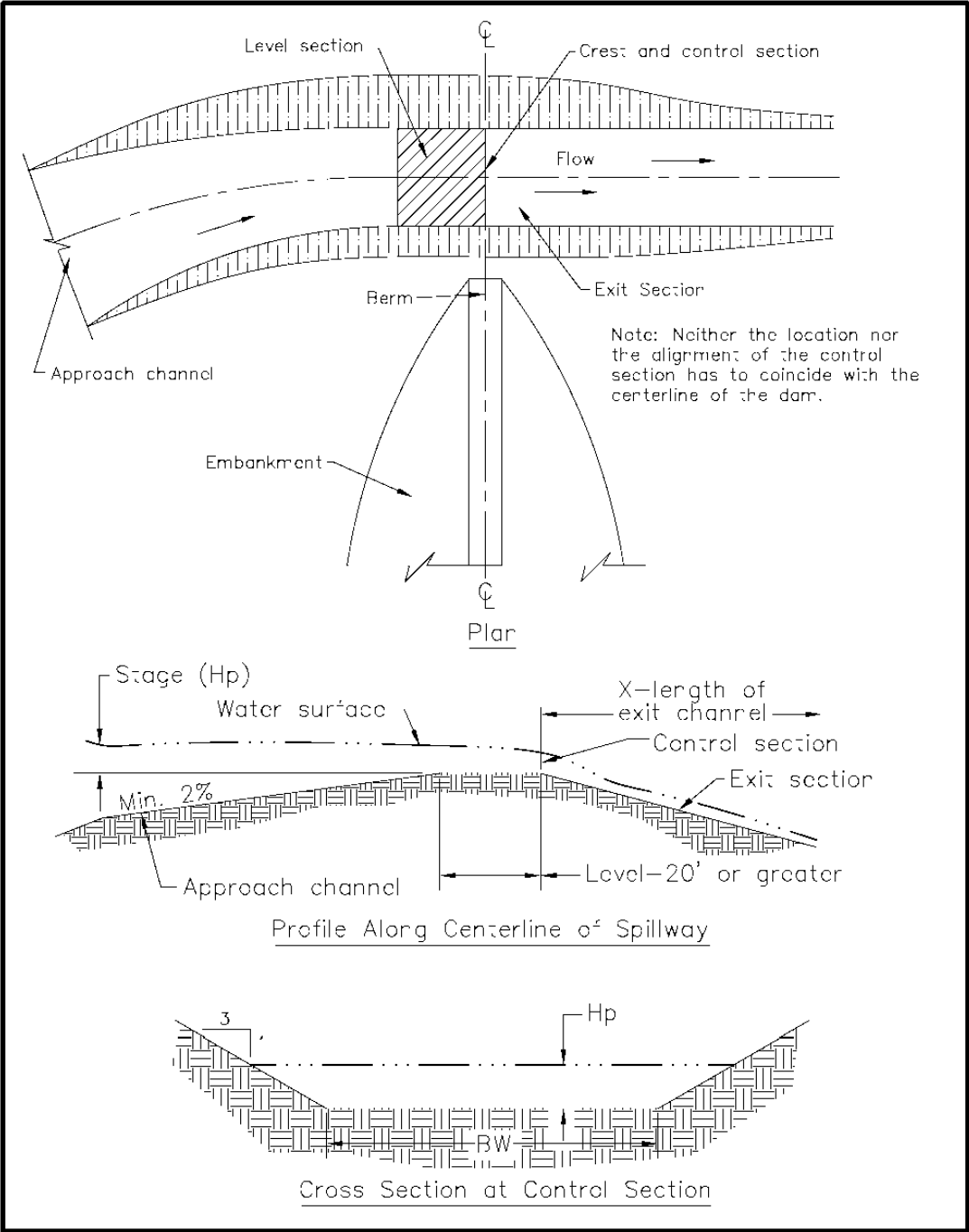

Figure SBN-4 Excavated grass spillway views

Inlet Section

Ensure that the approach section has a slope toward the impoundment area of not less than 2% and is flared at its entrance, gradually reducing to the design width of the control section. The inlet portion of the spillway may be curved to improve alignment.

The Control Section

The control section of the spillway should be level and straight and at least 20 ft long for grass spillways and 10 feet for riprap. Determine the width and depth for the required capacity and site conditions. Wide, shallow spillways are preferred because they reduce outlet velocities.

The Outlet Section

The outlet section of the spillway should be straight, aligned and sloped to assure supercritical flow with exit velocities not exceeding values acceptable for site conditions.

Outlet Velocity

Ensure that the velocity of flow from the basin is nonerosive for existing site conditions. It may be necessary to stabilize the downstream areas or the receiving channels.

Embankment

Embankments should not exceed 10 feet in height, measured at the center line from the original ground surface to the designed (settled) top elevation of the embankment. Keep a minimum of 1 foot between the designed (settled) top of the dam and the design water level in the emergency spillway. Additional freeboard may be added to the embankment height which allows flow through a designated bypass location. Construct embankments with a minimum top width of 8 feet and side slopes of 2.5:1 or flatter.

There should be a cutoff trench in stable soil material under the dam at the centerline. The trench should be at least 2 feet deep with 1.5:1 side slopes, and sufficiently wide (at least 8 ft.) to allow compaction by machine.

Embankment material should be a stable mineral soil, free of roots, woody vegetation, rocks or other objectionable materials, with adequate moisture for compaction. Place fill in 9-inch layers through the length of dam and compact by routing construction hauling equipment over it. Maintain moisture and compaction requirements according to the plans and specifications. Hauling or compaction equipment must traverse each layer so that the entire surface has been compacted by at least one pass of the equipment wheels or tracks.

Excavation

Where sediment pools are formed or enlarged by excavation, keep side slopes at 2:1 or flatter for safety.

Erosion Protection

Minimize the area disturbed during construction. Divert surface water from disturbed areas. When possible, delay clearing the sediment impoundment area until the dam is in place. Keep the remaining temporary pool area undisturbed. Stabilize the spillway, embankment, and all disturbed areas with permanent vegetation. The basin bottom should also be established to a vegetative cover as this promotes sediment deposition.

Trap Efficiency

Improve sediment basin trapping efficiency by employing the following considerations in the basin design:

- Surface area—In the design of the settling pond, allow the largest surface area possible. The shallower the pool, the better.
- Length—Maximize the length-to-width ratio of the basin to provide the longest flow path possible.
- Baffles—Provide a minimum of three porous baffles to evenly distribute flow across the basin and reduce turbulence.
- Inlets—Area between the sediment inlets and the basin bottom should be stabilized by geotextile material, riprap with geotextile, a pipe drop, or other similar methods (Figure SBN-5 shows the area with rocks). Inlets to basin should be located the greatest distance possible from the spillway.
- Dewatering—Allow the maximum reasonable detention period before the basin is completely dewatered (at least 48 hours).
- Inflow rate—Reduce the inflow velocity to nonerosive rates and divert all sediment-free runoff
- Establish permanent vegetation in the bottom and side slopes of the basin.
- Introduce the appropriate PAM material either at the turbulent entrance of the runoff water into the basin and/or apply to the first baffle. Apply the PAM according to manufacturer's recommendations.

Safety

Avoid steep side slopes. Fence basins properly and mark them with warning signs if trespassing is likely. Follow all State and local safety requirements.

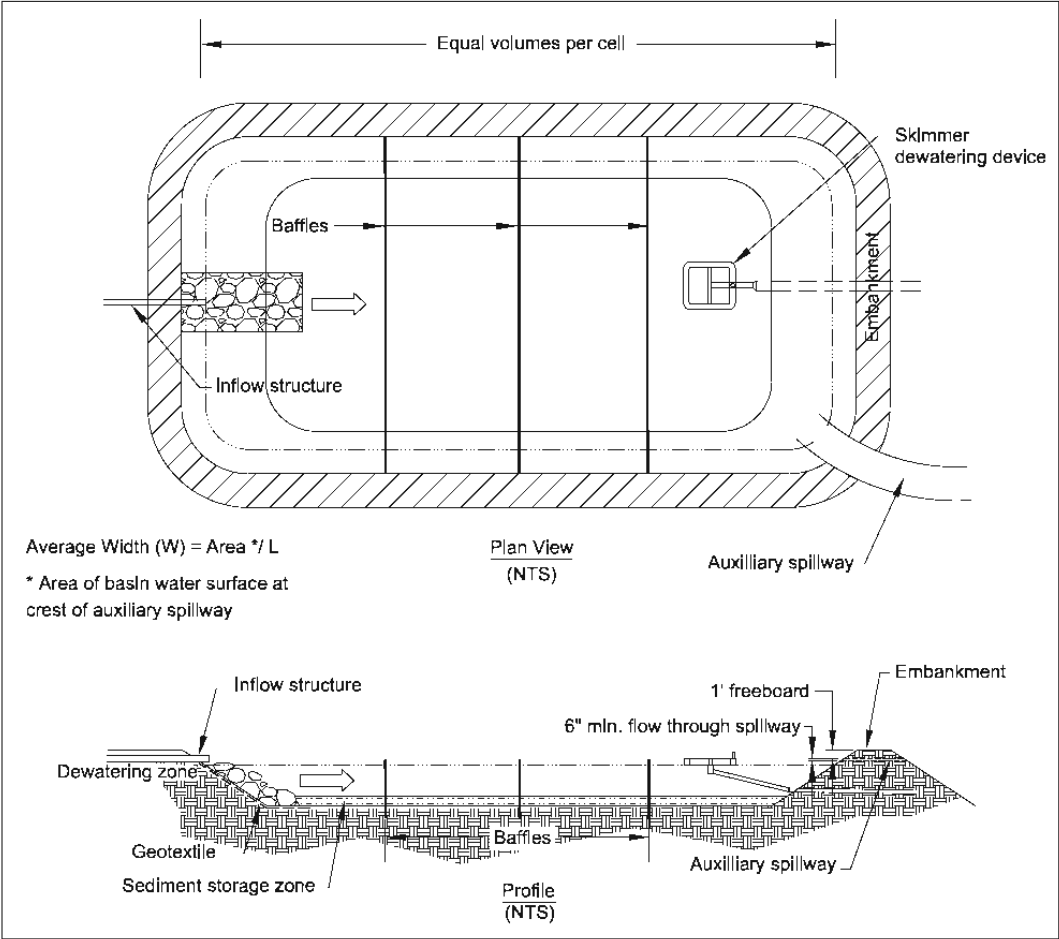

Figure SBN-5 Example of a sediment basin with a skimmer outlet and emergency spillway
(modified from Pennsylvania Erosion and Sediment Control Manual, March, 2000)

Design Procedure

Step 1. Determine peak flow, Q_{10} , for the basin drainage area utilizing the NRCS runoff curve number method.

Step 2. Determine any site limitations for the sediment pool elevation, emergency spillway or top of the dam.

Step 3. Determine basin volumes:

- Compute minimum volume required (3,600 ft³/acre of drainage area).
- Specify sediment cleanout level to be clearly marked (one-half the design volume). Specify that the basin area is to be cleared after the dam is built.

Step 4. Determine area of basin, shape of basin, and baffles:

- Check length/width ratio (should be 2:1 or larger) and the surface area (435 sq.ft./ Q_{p10}).
- Ensure the bottom of the basin is level.
- Design and locate a minimum of 3 coir baffles. The baffle spacing should produce equal volumes of storage within the basin when the basin is full. The top elevation of the baffles will be set in Step 7.

Step 5. Size the skimmer, skimmer orifice, and barrel pipe.

Use Table SBN-1 or the precise alternative design to size the orifice. Generally, a Schedule 40 PVC barrel pipe the same size as the skimmer arm is used under the embankment.

Step 6. Design the anti-seep collar.

Ensure that antiseep collar is no closer than 2 ft from a pipe joint and as close to the center of the embankment as possible. Collar must project at least 1.5 ft from the pipe and be watertight.

Step 7. Determine the emergency spillway dimensions.

Size the spillway bottom width and flow depth to handle the Q_{10} peak flow. Tables SBN-1 and SBN-2 can be used for the design process for grassed emergency spillways. Use appropriate design procedures for spillways with other surfaces. Set top of baffles at the elevation of the designed maximum flow depth of the emergency spillway.

Step 8. Spillway approach section.

Adjust the spillway alignment so that the control section and outlet section are straight. The entrance width should be 1.5 times the width of the control section with a smooth transition to the width of the control section. Approach channel should slope toward the reservoir no less than 2%.

Step 9. Spillway control section.

- Locate the control section in natural ground to the greatest extent possible.
- Keep a level area to extend at least 20 ft (grass) or 10 ft (riprap) upstream from the outlet end of the control section to ensure a straight alignment.
- Side slopes should be 3:1 (grass) or 2:1 (riprap).

Step 10. Design spillway exit section.

- Spillway exit should align with the control section and have the same bottom width and side slopes.
- Slope should be sufficient to maintain supercritical flow, but make sure it does not create erosive velocities for site conditions. (Stay within slope ranges in appropriate design tables.)
- Extend the exit channel to a point where the water may be released without damage.

Step 11. Size the embankment.

- Set the design elevation of the top of the dam a minimum of 1 ft above the water surface for the design flow in the emergency spillway.
- Constructed height should be 10% greater than the design to allow for settlement.
- Set side slopes 2.5:1 or flatter.
- Determine depth of cutoff trench from site borings. It should extend to a stable, tight soil layer (a minimum of 2 ft deep).
- Select borrow site remembering that the spillway cut may provide a significant amount of fill.

Step 12. Erosion control

- Select surface stabilization measures to control erosion.
- Select groundcover for emergency spillway to provide protection for design flow velocity and site conditions. Riprap stone over geotextile fabric may be required in erodible soils or when the spillway is not in undisturbed soils.
- Establish all disturbed areas including the basin bottom and side slopes to vegetation.

Step 13. Safety.

- Construct a fence and install warning signs as needed.

Table SBN-1 Design Table for Vegetated Spillways Excavated in Erosion Resistant Soils (side slopes 3 horizontal: 1 vertical)

Discharge Q CFS	Slope Range		Bottom Width Feet	Stage Feet	Discharge Q CFS	Slope Range		Bottom Width Feet	Stage Feet
	Minimum Percent	Maximum Percent				Minimum Percent	Maximum Percent		
15	3.3	12.2	8	.83	80	2.8	5.2	24	1.24
	3.5	18.2	12	.69		2.8	5.9	28	1.14
20	3.1	8.9	8	.97	2.9	7.0	32	1.06	
	3.2	13.0	12	.81	90	2.5	2.6	12	1.84
3.3	17.3	16	.70	2.5		3.1	16	1.61	
25	2.9	7.1	8	1.09	2.6	3.8	20	1.45	
	3.2	9.9	12	.91	2.7	4.5	24	1.32	
30	3.3	13.2	16	.79	2.8	5.3	28	1.22	
	3.3	17.2	20	.70	2.8	6.1	32	1.14	
35	2.9	6.0	8	1.20	100	2.5	2.8	16	1.71
	3.0	8.2	12	1.01		2.6	3.3	20	1.54
40	3.0	10.7	16	.88	2.6	4.0	24	1.41	
	3.3	13.8	20	.78	2.7	4.8	28	1.30	
45	2.8	5.1	8	1.30	2.7	5.3	32	1.21	
	2.9	6.9	12	1.10	2.8	6.1	36	1.13	
50	3.1	9.0	16	.94	120	2.5	2.8	20	1.71
	3.1	11.3	20	.85		2.6	3.2	24	1.56
55	3.2	14.1	24	.77	2.7	3.8	28	1.44	
	2.7	4.5	8	1.40	2.7	4.2	32	1.34	
60	2.9	6.0	12	1.18	2.7	4.8	36	1.26	
	2.9	7.6	16	1.03	140	2.5	2.7	24	1.77
3.1	9.7	20	.91	2.5		3.2	28	1.58	
65	3.1	11.9	24	.83	2.6	3.6	32	1.47	
	2.6	4.1	6	1.49	2.6	4.0	36	1.38	
70	2.8	5.3	12	1.25	2.7	4.5	40	1.30	
	2.9	6.7	16	1.09	160	2.5	2.7	28	1.70
3.0	8.4	20	.98	2.5		3.1	32	1.58	
75	3.0	10.4	24	.89	2.6	3.4	36	1.49	
	2.7	3.7	8	1.57	2.6	3.8	40	1.40	
80	2.8	4.7	12	1.33	2.7	4.3	44	1.33	
	2.8	6.0	16	1.16	180	2.4	2.7	32	1.72
2.9	7.3	20	1.03	2.4		3.0	36	1.60	
85	3.1	9.0	24	.94	2.5	3.4	40	1.51	
	2.6	3.1	8	1.73	2.6	3.7	44	1.43	
90	2.7	3.9	12	1.47	200	2.5	2.7	36	1.70
	2.7	4.8	16	1.28		2.5	2.9	40	1.60
95	2.9	5.9	20	1.15	2.5	3.3	44	1.52	
	2.9	7.3	24	1.05	2.6	3.6	48	1.45	
100	3.0	8.6	28	.97	220	2.4	2.6	40	1.70
	2.5	2.8	8	1.88		2.5	2.9	44	1.61
105	2.6	3.3	12	1.60	2.5	3.2	48	1.53	
	2.6	4.1	16	1.40	240	2.5	2.6	44	1.70
2.7	5.0	20	1.26	2.5		2.9	48	1.62	
110	2.8	6.1	24	1.15	2.6	3.2	52	1.54	
	2.9	7.0	28	1.05	260	2.4	2.6	48	1.70
2.5	2.9	12	1.72	2.5		2.9	52	1.62	
115	2.6	3.6	16	1.51	280	2.4	2.6	52	1.70
	2.7	4.3	20	1.35		2.5	2.9	56	1.69

Example of Table Use:

Given: Discharge, $Q_{10} = 87$ cfs, Spillway slope (exit section) = 4%.

Find: Bottom Width and Stage in Spillway.

Procedure: Using a discharge of 90 cfs, note that the spillway (exit section) slope falls within slope ranges corresponding to bottom widths of 24, 28, and 32 ft. Use bottom width of 32 ft, to minimize velocity. Stage in the spillway is 1.14 ft.

Note: Computations are based on: Roughness coefficient, $n = 0.40$ and a maximum velocity of 5.50 ft. per sec.

Table SBN-2 Design Table for Vegetated Spillways Excavated in Very Erodible Soils (side slopes 3 horizontal: 1 vertical)

Discharge Q CFS	Slope Range		Bottom Width Feet	Stage Feet
	Minimum Percent	Maximum Percent		
10	3.5	4.7	8	.68
15	3.4	4.4	12	.69
	3.4	5.9	16	.60
20	3.3	3.3	12	.80
	3.3	4.1	16	.70
	3.5	5.3	20	.62
25	3.3	3.3	16	.79
	3.3	4.0	20	.70
	3.5	4.9	24	.64
30	3.3	3.3	20	.78
	3.3	4.0	24	.71
	3.4	4.7	28	.65
	3.4	5.5	32	.61
35	3.2	3.2	24	.77
	3.3	3.9	28	.71
	3.5	4.6	32	.66
	3.5	5.2	36	.62
40	3.3	3.3	28	.76
	3.4	3.8	32	.71
	3.4	4.4	36	.67
45	3.4	5.0	40	.64
	3.3	3.3	32	.76
	3.4	3.8	36	.71
	3.4	4.3	40	.67
50	3.4	4.8	44	.64
	3.3	3.3	36	.75
	3.3	3.8	40	.71
60	3.3	4.3	44	.68
	3.2	3.2	44	.75
	3.2	3.7	48	.72
70	3.3	3.3	52	.75
80	3.1	3.1	56	.78

Example of Table Use:

Given: Discharge, $Q_{10} = 38$ cfs, Spillway slope (exit section) = 4%.

Find: Bottom Width and Stage in Spillway.

Procedure: Using a discharge of 40 cfs, note that the spillway (exit section) slope falls within slope ranges corresponding to bottom widths of 36 and 40 ft. Use bottom width of 40 ft, to minimize velocity. Stage in the spillway is 0.64 ft.

Note: Computations are based on: Roughness coefficient, $n = 0.40$ and a maximum velocity of 3.50 ft. per sec.

Outlet Protection (OP)



Practice Description

This practice is designed to prevent erosion at the outlet of a channel or conduit by reducing the velocity of flow and dissipating the energy. Outlet protection measures usually consist of a riprap-lined apron, a reinforced concrete flume with concrete baffles, a reinforced concrete box with chambers or baffles and possibly pre-manufactured products. This practice applies wherever high velocity discharge must be released on erodible material.

Planning Considerations

The outlets of pipes and structurally lined channels are points of critical erosion potential. Stormwater which is transported through man-made conveyance systems at design capacity generally reaches a velocity which exceeds the ability of the receiving channel or area to resist erosion. To prevent scour at stormwater outlets, a flow transition structure is required which will absorb the initial impact of the flow and reduce the flow velocity to a level which will not erode the receiving channel or area of discharge.

The most commonly used structure for outlet protection is an erosion resistant lined apron. These aprons are generally lined with loose rock riprap, grouted riprap or concrete. They are constructed at zero grade for a distance which is related to the outlet flow rate and the tailwater level. Criteria for designing these structures are contained in this practice. Several outlet conditions are shown in Figure OP-1. Example design problems for outlet protection are found at the end of this practice.

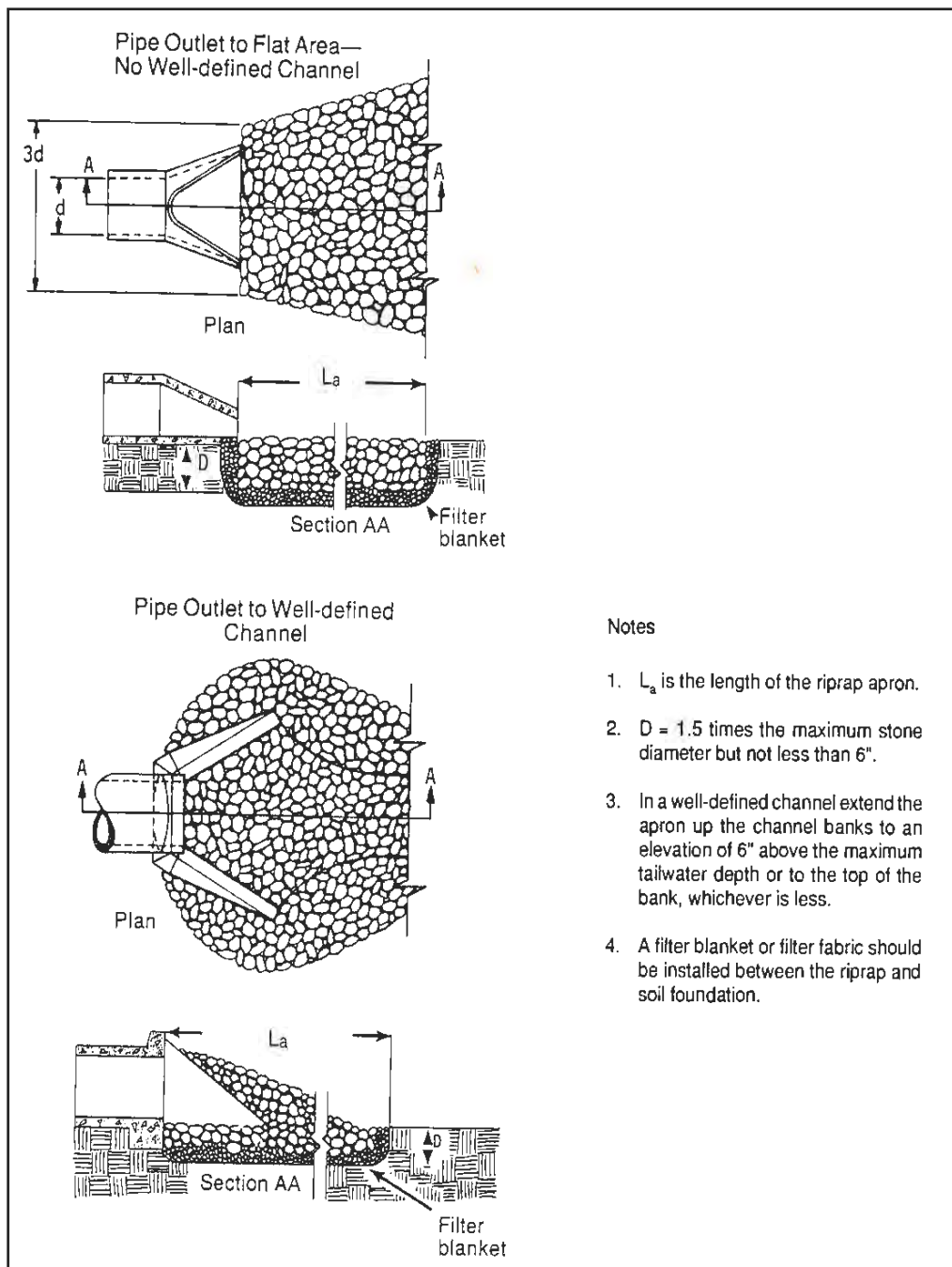

Figure OP-1 Pipe Outlet Conditions

Where the flow is excessive for the economical use of an apron, excavated stilling basins may be used. Acceptable designs for stilling basins may be found in the following documents available from the U. S. Government Printing Office.

- 1) Hydraulic Design of Energy Dissipaters for Culverts and Channels, Hydraulics Engineering Circular No.14, U. S. Department of Transportation, Federal Highway Administration.

- 2) Hydraulic Design of Stilling Basins and Energy Dissipaters, Engineering Monograph No.25 U. S. Department of Interior-Bureau of Reclamation.

Design Criteria

Structurally lined aprons at the outlets of pipes and paved channel sections should be designed according to the following criteria:

Pipe Outlets

Capacity

The structurally lined apron should have the capacity to carry the peak stormflow from the 25-year 24-hour frequency storm or the storm specified in state laws or local ordinances or the design discharge of the water conveyance structure, whichever is greatest.

Tailwater

The depth of tailwater immediately below the pipe outlet must be determined for the design capacity of the pipe. Manning's Equation may be used to determine tailwater depth. Manning's Equation may be found in the practice Grass Swales. If the tailwater depth is less than half the diameter of the outlet pipe, it shall be classified as a Minimum Tailwater Condition. If the tailwater depth is greater than half the pipe diameter, it shall be classified as a Maximum Tailwater Condition. Pipes which outlet to flat areas, with no defined channel, may be assumed to have a Minimum Tailwater Condition.

Apron Length

The apron length should be determined from Figure OP-2 or OP-3 according to the tailwater condition.

Apron Thickness

The apron thickness should be determined by the maximum stone size (d_{max}), when the apron is lined with riprap. The maximum stone size shall be $1.5 \times d_{50}$ (median stone size), as determined from Figure OP-2 or OP-3. The apron thickness shall be $1.5 \times d_{max}$.

When the apron is lined with concrete, the minimum thickness of the concrete shall be 4".

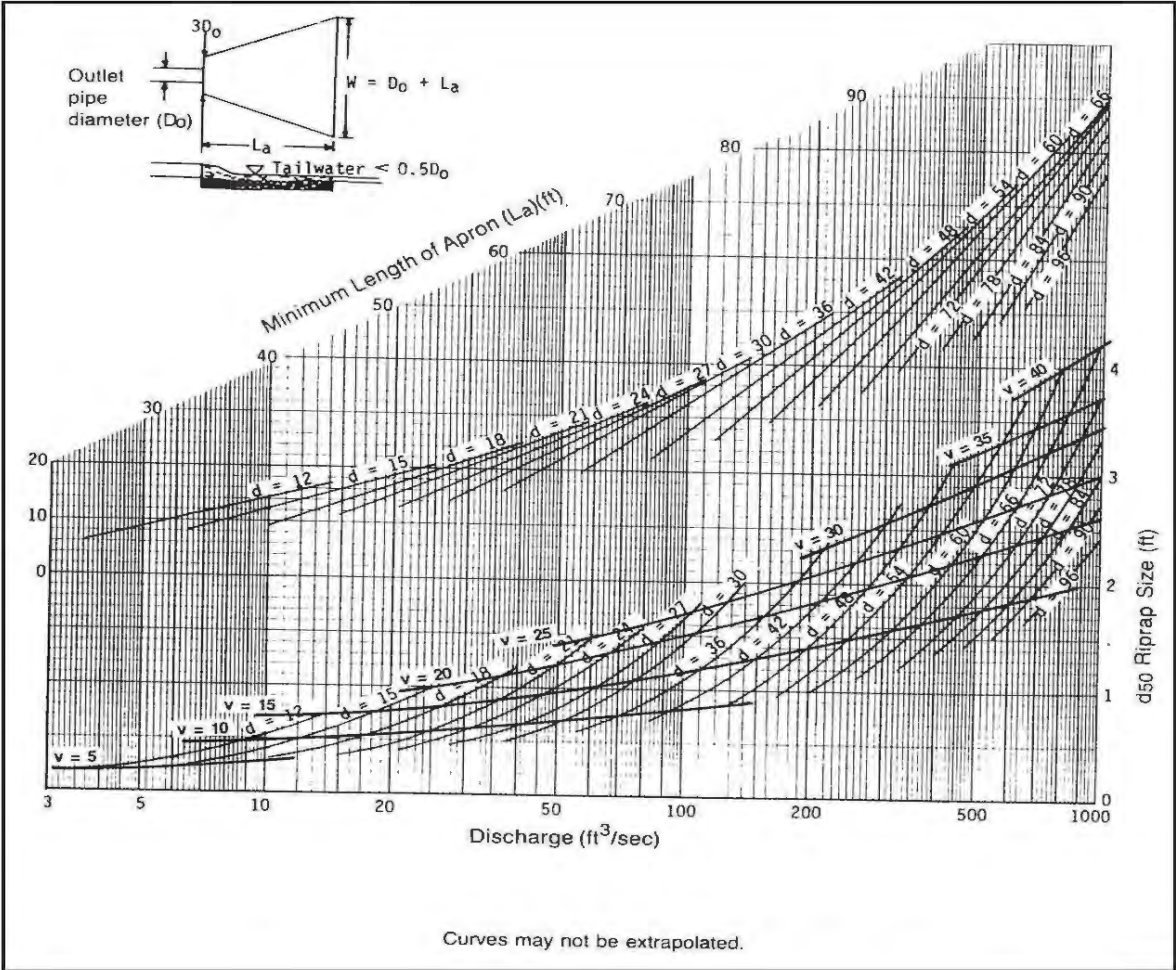

Figure OP-2 Outlet Protection Design for Tailwater < 0.5 Diameter

Apron Width

If the pipe discharges directly into a well-defined channel, the apron should extend across the channel bottom and up the channel banks to an elevation 1 foot above the maximum tailwater depth or to the top of the bank, whichever is the least.

If the pipe discharges onto a flat area with no defined channel, the width of the apron should be determined as follows:

- The upstream end of the apron, adjacent to the pipe, should have a width 3 times the diameter of the outlet pipe.
- For a Minimum Tailwater Condition, the downstream end of the apron should have a width equal to the pipe diameter plus the length of the apron obtained from the figures.
- For a Maximum Tailwater Condition, the downstream end shall have a width equal to the pipe diameter plus 0.4 times the length of the apron from Figures OP-2 or OP-3.

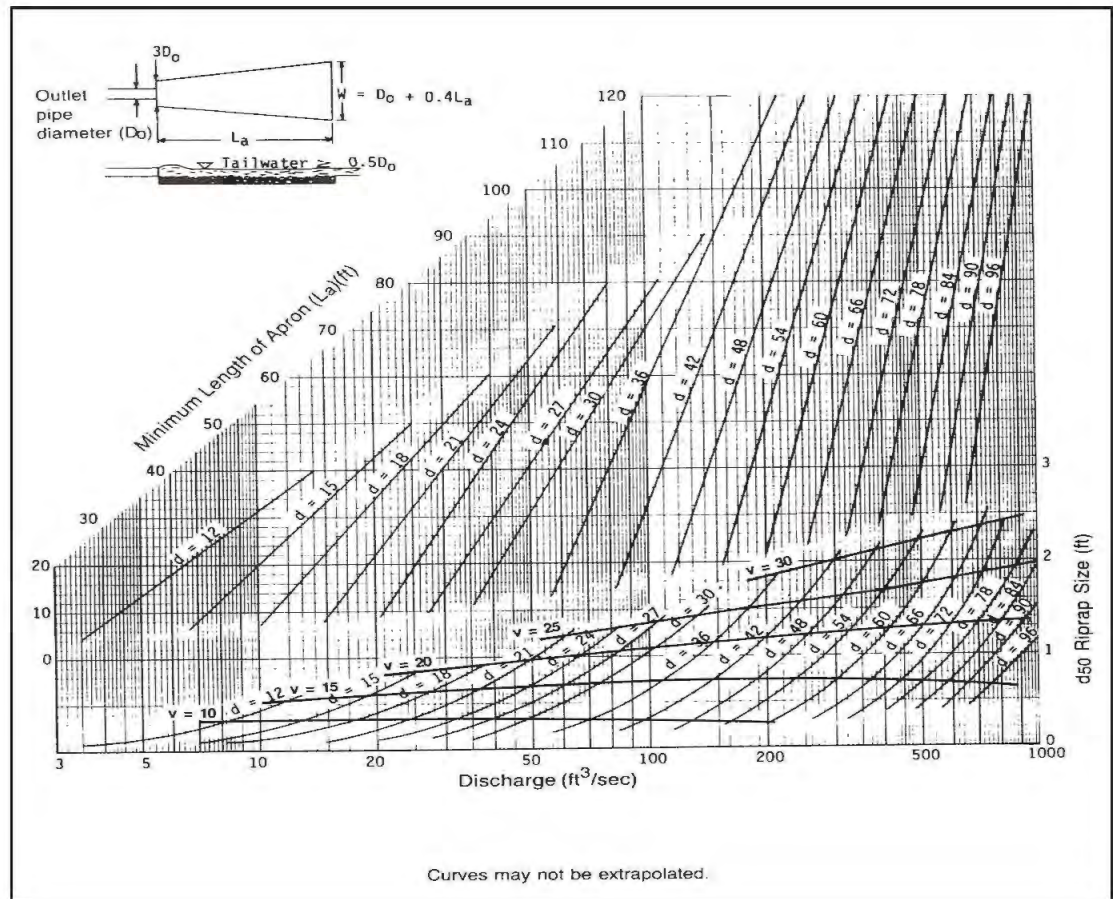

Figure OP-3 Outlet Protection Design for Tailwater ≥ 0.5 Diameter

Bottom Grade

The apron should be constructed with no slope along its length (0.0% grade). The invert elevation of the downstream end of the apron shall be equal to the elevation of the invert of the receiving channel. There shall be no overfall at the end of the apron.

Side Slope

If the pipe discharges into a well-defined channel, the side slopes of the channel should not be steeper than 2:1 (Horizontal:Vertical).

Alignment

The apron should be located so that there are no bends in the horizontal alignment.

Geotextile

When riprap is used to line the apron, non-woven geotextile should be used as a separator between the graded stone, the soil subgrade, and the abutments. Geotextile should be placed immediately adjacent to the subgrade without any voids between the fabric and the subgrade. The geotextile will prevent the migration of soil particles from the subgrade into the graded stone. The geotextile shall be of the strength and durability required for the project to ensure the aggregate and soil base are stable. Generally, the non-woven geotextile should meet the requirements found in ASSHTO M288.

Materials

The apron may be lined with loose rock riprap, grouted riprap, or concrete. The median sized stone for riprap should be determined from the curves on Figure OP-2 and OP-3 according to the tailwater condition.

After the median stone size is determined, the gradation of rock to be used should be specified using Tables OP-2 and OP-3. Table OP-2 is used to determine the weight of the median stone size (d_{50}). Using this median weight, a gradation can be selected from Table OP-3, which shows the commercially available riprap gradations as classified by the Alabama Department of Transportation.

Stone for riprap should consist of field stone or rough unhewn quarry stone of approximately rectangular shape. The stone should be hard and angular and of such quality that it will not disintegrate on exposure to water or weathering and it shall be suitable in all other respects for the purpose intended. The specific gravity of the individual stones should be at least 2.5.

When the apron is lined with concrete, the concrete should have a minimum compressive strength at 28 days of 3000 pounds per square inch. American Concrete Institute guidelines should be used to design concrete structures and reinforcement. As a minimum, the concrete should be reinforced with steel welded wire fabric.

Table OP-2 Size of Riprap Stones

Weight	Mean Spherical Diameter (feet)	Rectangular Shape	
		Length	Width, Height (feet)
50	0.8	1.4	0.5
100	1.1	1.75	0.6
150	1.3	2.0	0.67
300	1.6	2.6	0.9
500	1.9	3.0	1.0
1000	2.2	3.7	1.25
1500	2.6	4.7	1.5
2000	2.75	5.4	1.8
4000	3.6	6.0	2.0
6000	4.0	6.9	2.3
8000	4.5	7.6	2.5
20000	6.1	10.0	3.3

Table OP-3 Graded Riprap

Class	Weight (lbs.)					
	d ₁₀	d ₁₅	d ₂₅	d ₅₀	d ₇₅	d ₉₀
1	10	-	-	50	-	100
2	10	-	-	80	-	200
3	-	25	-	200	-	500
4	-	-	50	500	1000	-
5	-	-	200	1000	-	2000

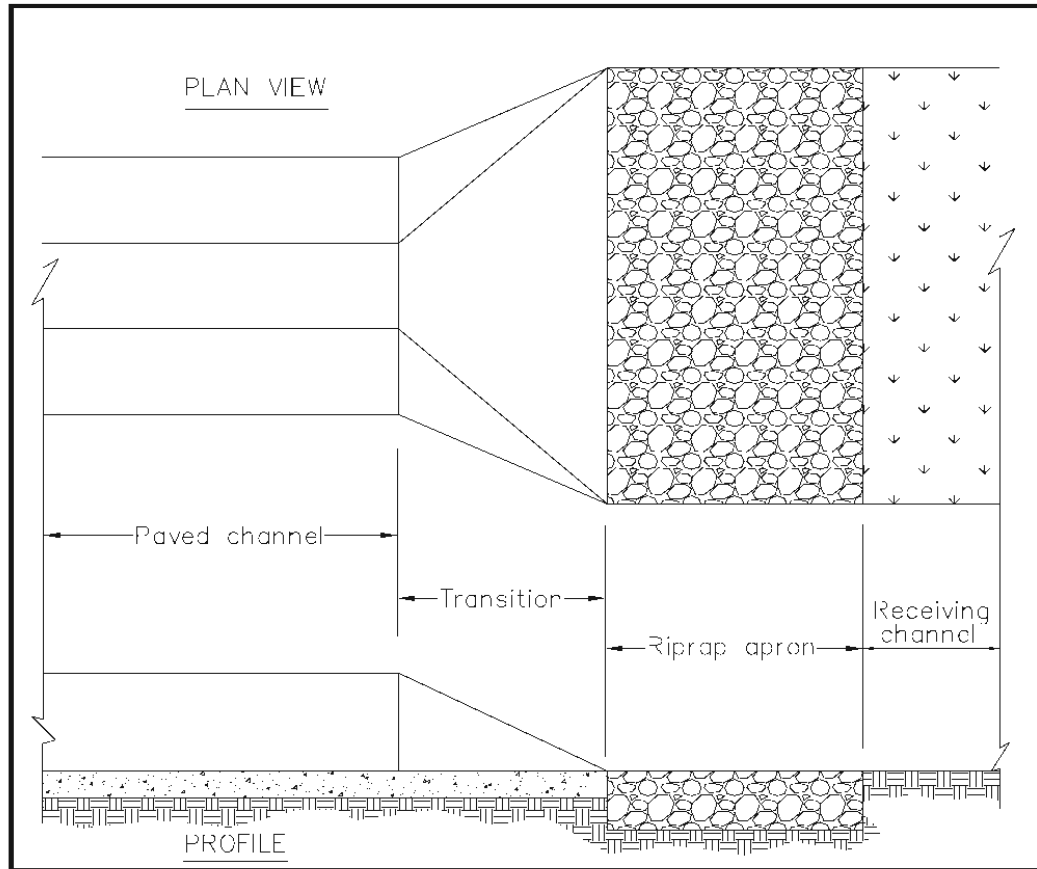

Figure OP-4 Paved Channel Outlet

- 1) The flow velocity at the outlet of paved channels flowing at design capacity should not exceed the velocity, which will cause erosion and instability in the receiving channel.
- 2) The end of the paved channel should merge smoothly with the receiving channel section. There should be no overfall at the end of the paved section. Where the bottom width of the paved channel is narrower than the bottom width of the receiving channel, a transition section should be provided. The maximum side divergence of the transition shall be 1 in 3F where

$$F = v/gd, \text{ and}$$

$$F = \text{Froude no.}$$

$$V = \text{Velocity at beginning of transition (ft./sec.)}$$

$$d = \text{Dept of flow at beginning of transition (feet.)}$$

$$g = 32.2 \text{ ft./sec.}^2$$

- 3) Bends or curves in the horizontal alignment of the transition are not allowed unless the Froude no. (F) is 0.8 or less, or the section is specifically designed for turbulent flow.

Example Design Problems

Example 1

Given: An 18" pipe discharges 24 cu. ft/sec at design capacity onto a grassy slope (no defined channel).

Find: The required length, width and median stone size (d_{50}) for a riprap-lined apron.

Solution

Since the pipe discharges onto a grassy slope with no defined channel, a Minimum Tailwater Condition may be assumed.

From Figure OP-2, an apron length (L_a) of 20 feet and a median stone size (d_{50}) of 0.8 feet is determined.

The upstream apron width equals 3 times the pipe diameter: $3 \times 1.5 \text{ feet} = \underline{4.5 \text{ feet}}$.

The downstream apron width equals the apron length plus the pipe diameter: $20 \text{ feet} + 1.5 \text{ foot} = \underline{21.5 \text{ feet}}$.

Example 2

Given: The pipe in example No. 1 discharges into a channel with a triangular cross section, 2 feet deep and 2:1 side slopes. The channel has a 2% slope and an "n" coefficient of 0.045.

Find: The required length, width and the median stone size (d_{50}) for a riprap lining.

Solution

Determine the tailwater depth using Manning's Equation and the Continuity Equation.

$$Q = 1.49/n R^{2/3} S^{1/2} A$$

$$24 = 1.49/n [2d/4.47]^{2/3} (.02)^{1/2} (2d^2)$$

where, d = depth of tailwater
 $d = 1.74 \text{ feet.}^*$

*Since d is greater than half the pipe diameter, a Maximum Tailwater Condition exists.

From Figure OP-3, a median stone size (d_{50}) of 0.5 feet. and an apron length (L_a) of 41 feet. is determined.

The entire channel cross section should be lined, since the maximum tailwater depth is within 1 foot of the top of the channel.

6. Spill Prevention Control and Countermeasures Plan

6.1. General Applicability

Title 40, Part 112 of the Code of Federal Regulations (40 CFR 112), requires the preparation and implementation of a Spill Prevention Control and Countermeasure (SPCC) Plan for any non-transportation-related facility, which due to its location, could reasonably be expected to discharge oil into or upon the navigable waters of the United States in quantities that may be harmful (as defined in 40 CFR 110) and that has the capacity to store oil in volumes greater than:

- 1,320 gallons in total aboveground storage (counting only containers with an oil storage capacity of 55 gallons or more and including equipment containing oil for ancillary purposes) or
- 42,000 gallons in total completely buried storage (not counting completely buried containers that are currently subject to all of the technical requirements of 40 CFR 280 or all of the technical requirements of a State program approved under 40 CFR 281).

Davis Materials, Inc. plans to store petroleum products at the pit in excess of 1,320 gallons. Davis Materials, Inc. is required to have an SPCC plan.

6.2. No Potential for Substantial Harm

As a requirement of the Oil Pollution Act of 1990, any SPCC-regulated facility that could cause "substantial harm" to the environment as a result of a discharge of oil, is required to prepare and implement a Facility Response Plan in accordance with 40 CFR § 112, Subpart D. The "Flowchart of Criteria for Substantial Harm", shown as Figure 6-1, shows that the facility does not pose a substantial harm to the environment and, therefore, is not required to prepare and implement a Facility Response Plan.

6.3. Purpose

The purpose of this Chapter is to serve as the Spill Prevention Control and Countermeasures (SPCC) Plan for Davis Materials, Inc. at its Vance Pit. A complete copy of this SPCC Plan is to be kept and available to regulatory agencies for onsite review during normal working hours (facilities attended at least 4 hours a day) in accordance with 40 CFR 112.3(e).

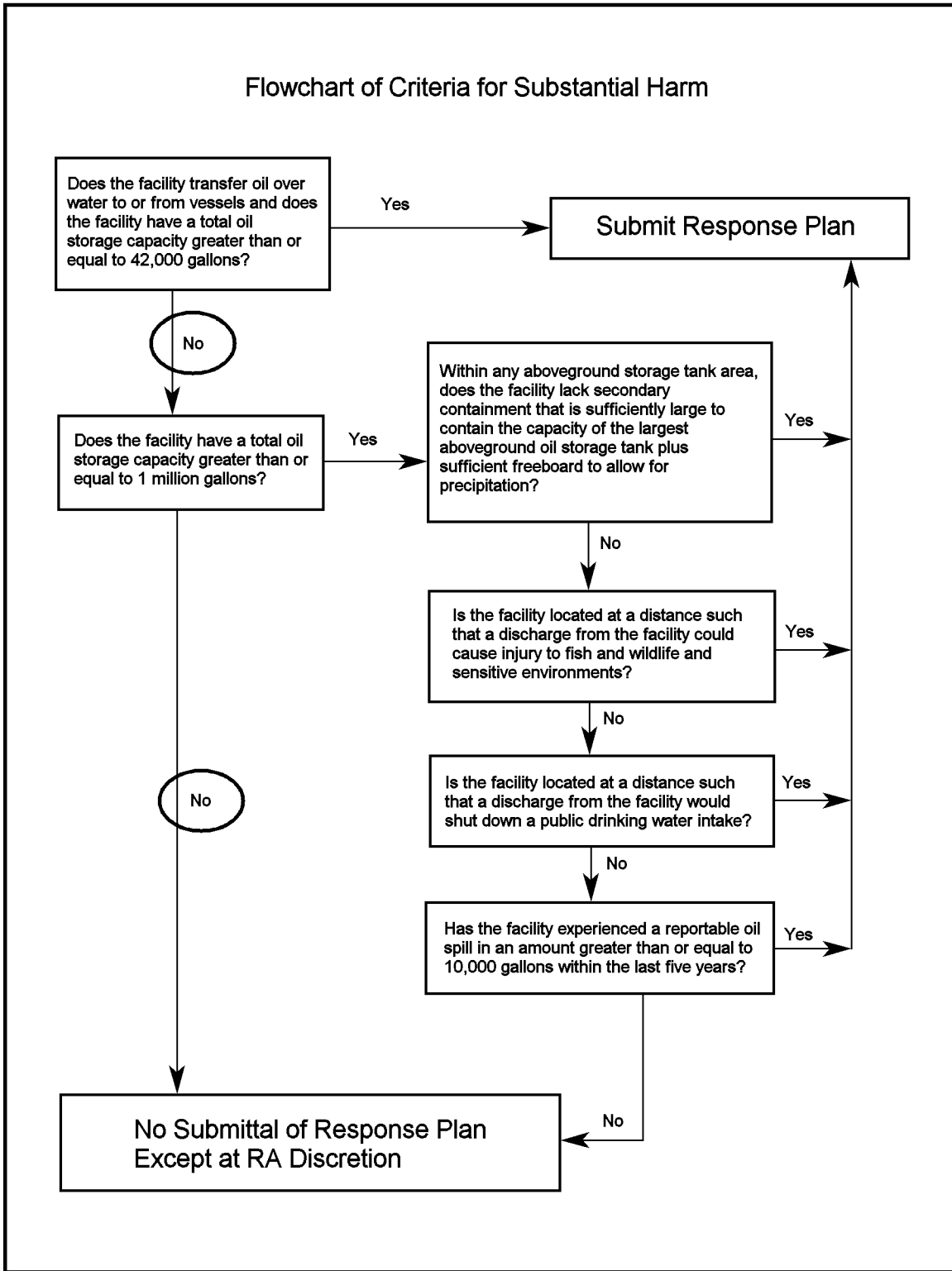

Figure 6-1. Flowchart of Criteria for Substantial Harm.

6.4. Facility Owner, Address, and Telephone

Contact and SPCC Coordinator:

Ronald T. Davis, Vice-President
(205) 345-6655

Physical Address:

Vance Pit
Story Road
Vance, AL 35490

Mailing Address:

Davis Materials, Inc.
P.O. Box 1099
Tuscaloosa, AL 35403

6.5. Facility Operations

The Vance Pit of Davis Materials, Inc. will produce crushed stone aggregate for commercial use.

6.6. Petroleum Storage

Davis Materials, Inc. plans to store diesel fuel at the pit using two double-walled, steel, diesel tanks. The maximum volume of each tank will be approximately 1,000 gallons. Any other petroleum (i.e., motor oils, hydraulic oil, lubricating oil, etc.) will be stored on spill containment pallets.

6.7. Petroleum Transfer Procedures

In order to lessen the probability of discharges during transfers, the following discharge prevention procedures will be utilized:

- Prior to transferring any material into a container, the person transferring the material will make sure that the available volume of the container is greater than the amount that will be transferred to the container.
- During the entire time that material is being transferred to a container, the person transferring the material must continually monitor the transfer process.
- Container level gauges, if present, will be continuously monitored during transfers.
- No smoking is allowed within 25 feet of a storage or transfer area during transfers.
- No fire, open flames or welding is allowed within 25 feet of a storage and transfer area during transfers.
- The hand brake must be engaged and the wheels chocked on any vehicle that is transferring material.
- Tools that are likely to reduce the effectiveness of the closure of any valve of a storage container will not be used.
- After transferring, any manholes and valves associated with a storage container will be closed and secured.
- Warning signs will be in-place to warn personnel not to move transfer vehicles until all transfer lines have been completely disconnected.

- Prior to the departure of a transfer vehicle, the lower most outlets of the vehicle will be examined for leakage and, if necessary, tightened, adjusted or replaced to prevent leakage.
- During transfer, all associated equipment will be properly grounded to prevent sparking from the discharge of static electricity built up within the transfer line.
- Contractors retained to transfer at this facility will be apprised of their responsibility for discharge prevention and, if necessary, discharge response during such transfers.

6.8. Discharge Prevention Measures

All containers used for storage at this facility will be of a material and construction compatible with the material stored and conditions of storage such as pressure and temperature. The secondary containment containers will be constructed of materials sufficiently impervious to contain the discharged material. The secondary containment containers will contain a volume greater than that of the largest container.

Drainage of uncontaminated storm water from a secondary containment to a permitted outfall is not allowed unless:

- The bypass valve is normally sealed closed;
- The retained storm water is inspected to ensure that no sheen nor discoloration is present;
- The bypass valve is opened, then resealed following draining under responsible supervision; and
- Adequate records are kept of the drainage events (i.e., records required under the National Pollutant Discharge Elimination System permit).

The storage containers will be inspected on a routine basis. Visual inspections will include checking the outside of the containers, supports, gauges, valves, fittings, and piping for damage, deterioration, or any accumulation of material inside diked areas.

Visible discharges that result in a loss of material from a container will be promptly corrected. Any material that accumulates within a diked area will be promptly removed.

The requirements to provide corrosion protection for completely or partially buried metallic storage containers will not be applicable because there will be no buried metallic storage containers at this facility. The requirements to protect buried piping will not be applicable because there will be no buried piping at this facility associated with oil storage. Containers, aboveground piping, and transfer operations will be protected from vehicles.

6.9. Discharge Discovery, Response and Cleanup

In the event of a discharge at this facility, the following actions will be taken, as appropriate, by facility personnel upon discovery of the discharge:

- If safely possible, attempt to stop additional discharge from the container, piping, hose or other source. Use emergency shut-off if available.
- Follow the facility's emergency response plan and use the facility's emergency notification system to warn facility occupants of the emergency. Contact the SPCC Coordinator and apprise him of the situation.
- Shut off any ignition sources (i.e., motors, electrical circuits, open flames, etc.) that could cause a fire in the vicinity of any discharged oil.
- Secure containment of the discharged material. Make sure secondary containment structures are secure and have temporary containment equipment ready in case the discharged material escapes the secondary containment; priority should be given to containing the discharge on the facility's property and protecting storm drains and other access points to surface water.
- When necessary, the SPCC Coordinator will retain a contractor to clean up and dispose of the discharged material.
- When necessary, the SPCC Coordinator will report the discharge to the appropriate authorities.

6.10. Disposal of Recovered Materials

Disposal of recovered discharged materials will take place in accordance with applicable legal requirements.

6.11. Emergency Contact List

Name	Telephone
Ronald T. Davis, Vice-President/ SPCC Coordinator	(205) 310-1380 (205) 345-6622
National Response Center (NRC)	(800) 424-8802
Alabama Department of Environmental Management (ADEM) (After Hours, Call Birmingham Field Office)	(334) 271-7700 After Hours: (205) 942-6168
U.S. Environmental Protection Agency (EPA): Regional Administrator	(404) 562-8700

6.12. Discharge Reporting Information

In the event of an oil discharge from this facility that reaches navigable waters, the following information will be collected and reported to the individuals and organizations named in the Emergency Contact List above:

- Facility address;
- Facility telephone number;
- Date and time of the oil discharge;
- Type of oil discharged;
- Estimate of the total quantity of oil discharged;
- Source of the discharged oil;
- Description of affected media (i.e., water, shoreline, etc.);
- Cause of the oil discharge;
- Damages and/or injuries resulting from the oil discharge;
- Actions taken to stop, remove or mitigate the effects of the oil discharge;
- Whether an evacuation may be needed; and
- Names of individuals and/or organizations that have been contacted.

6.13. Discharge Reporting Deadlines

Notification, by phone, containing the above specific information, must be made to the NRC immediately upon knowledge of whenever the facility has discharged (spilled or released) a harmful quantity of oil (violated water quality standard or caused a film or sheen) into navigable waters.

ADEM requires notification within 24 hours for spills or discharges requiring notification of the NRC.

The SPCC Coordinator must submit specific information to the EPA Regional Administrator within sixty (60) days of either of the following occurrences:

- Whenever the facility has discharged 1,000-gallons or more of oil in a single discharge into navigable waters of the state or adjoining shorelines.
- Whenever the facility has discharged more than 42-gallons of oil in each of two discharges occurring within any twelve-month period.

6.14. Personnel Training

All materials-handling personnel will be trained, at a minimum, with regard to the contents of this SPCC Plan. Supplemental information could include general facility operations, operation and maintenance procedures to prevent discharges, discharge procedure protocols, and applicable pollution control laws and regulations

Discharge prevention briefings will be scheduled and conducted for all materials-handling personnel annually to assure adequate understanding of this SPCC Plan. These briefings, at a minimum, will highlight and describe known discharges or failures, malfunctioning components and any recently developed precautionary measures.

Training records will be maintained by the facility.

6.15. Security

The facility is fenced with access through a gate at the highway.

7. Drawings

The drawings of the site are included in this chapter.

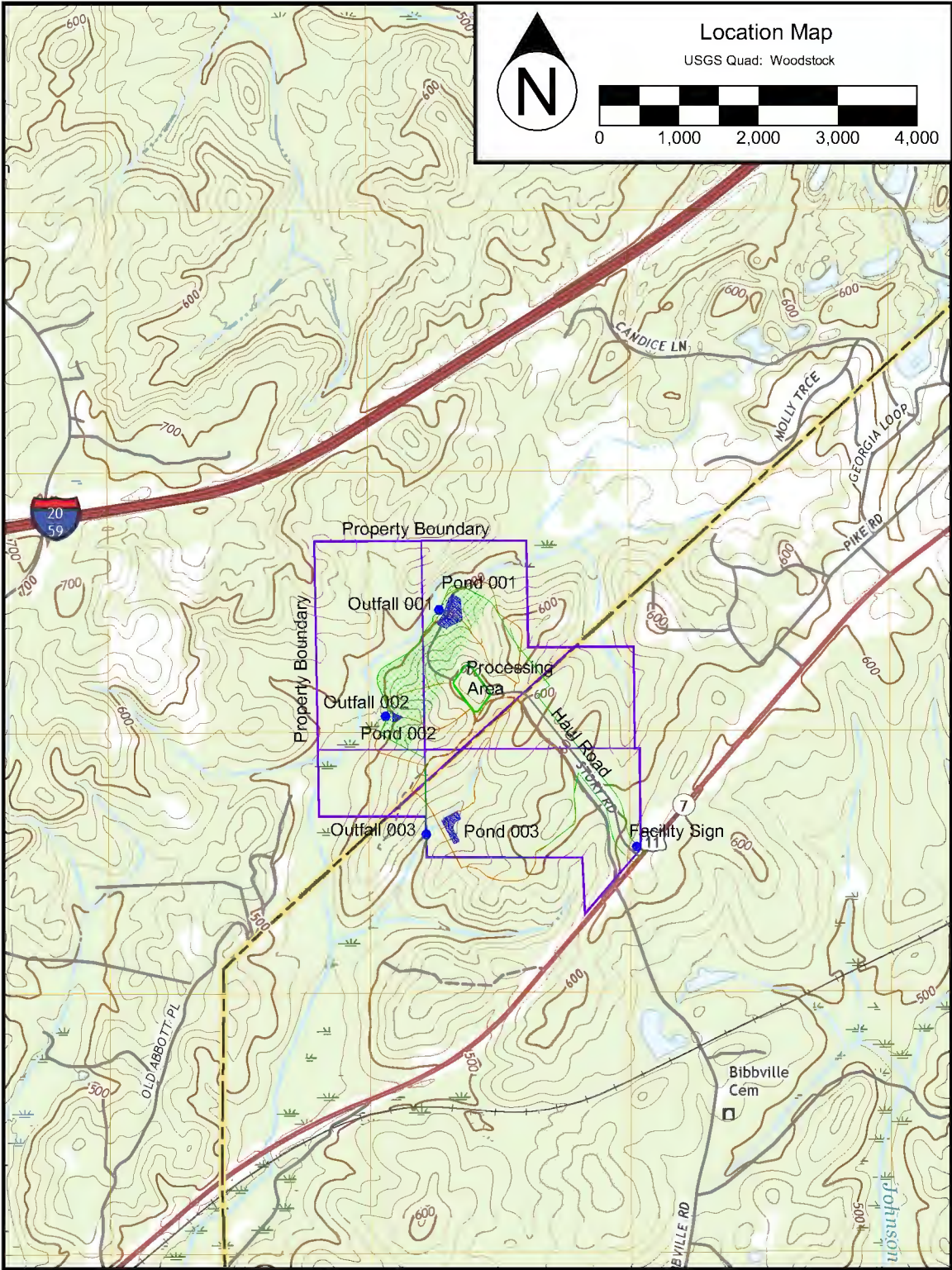

Vance Pit Location Map.

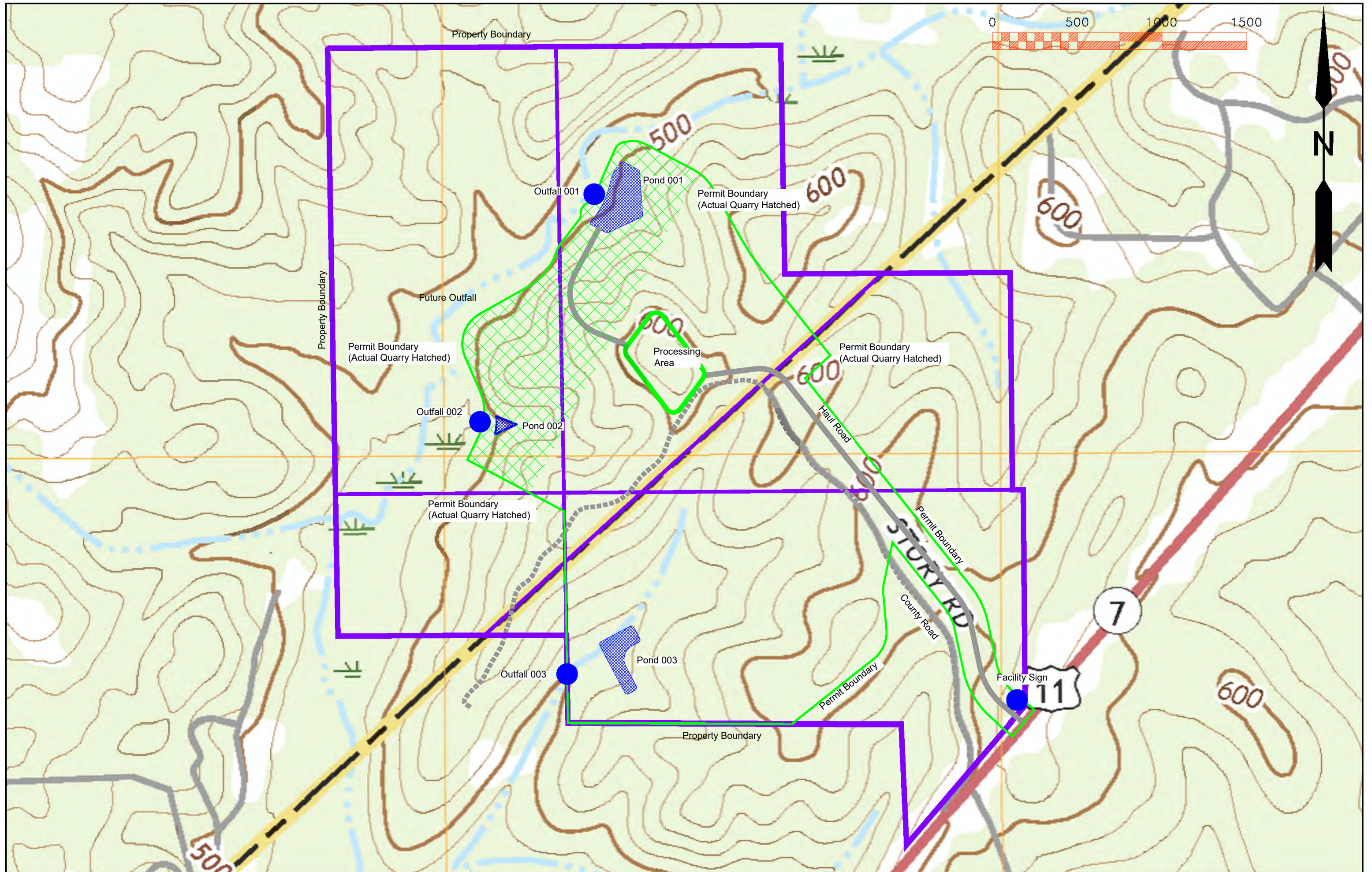

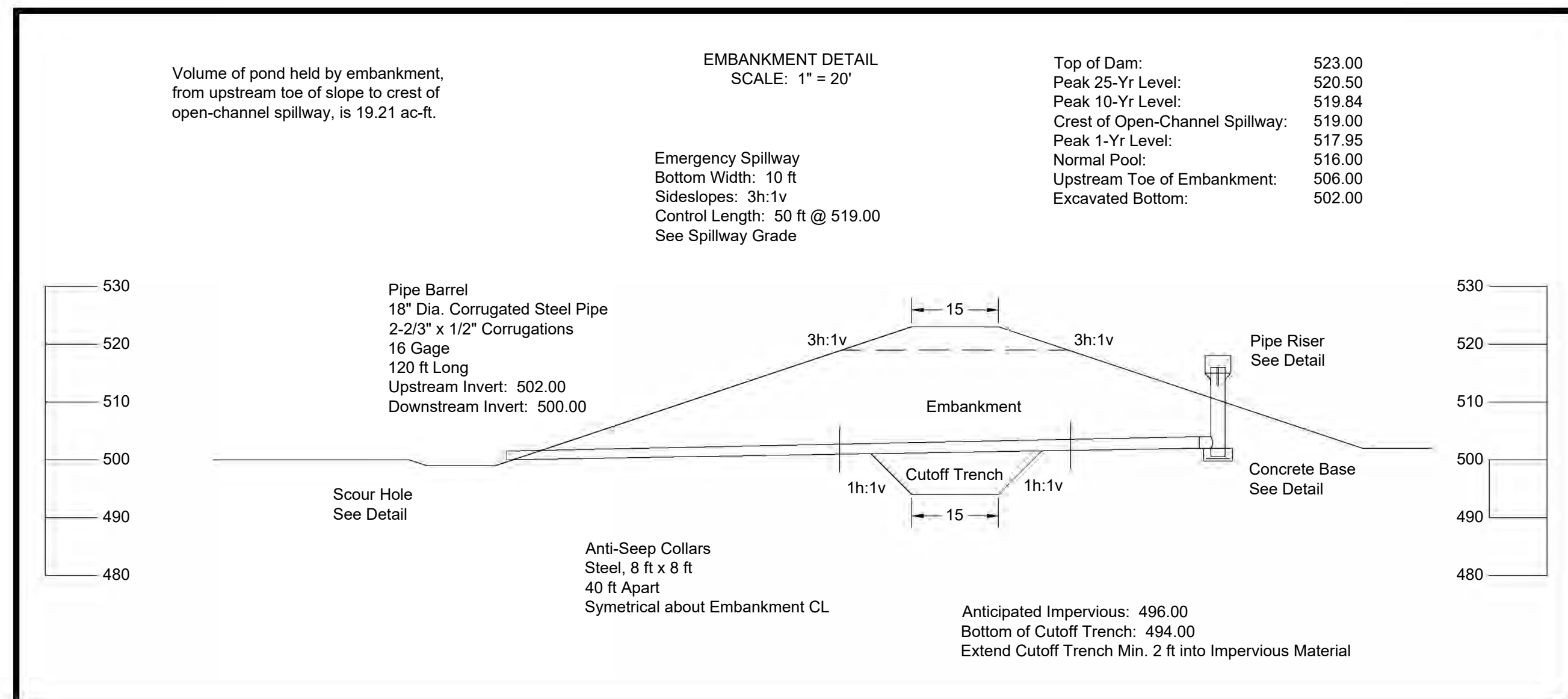
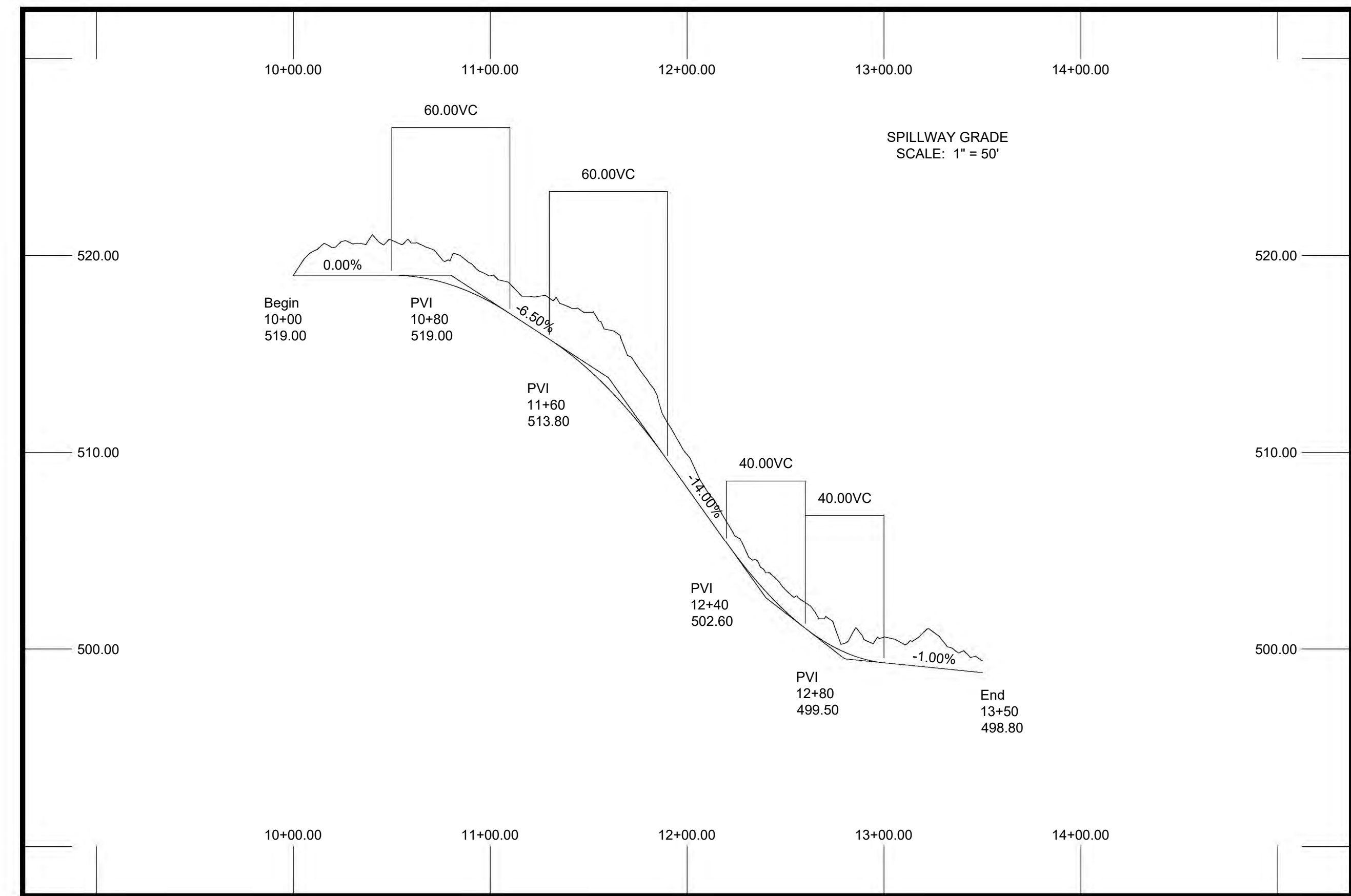
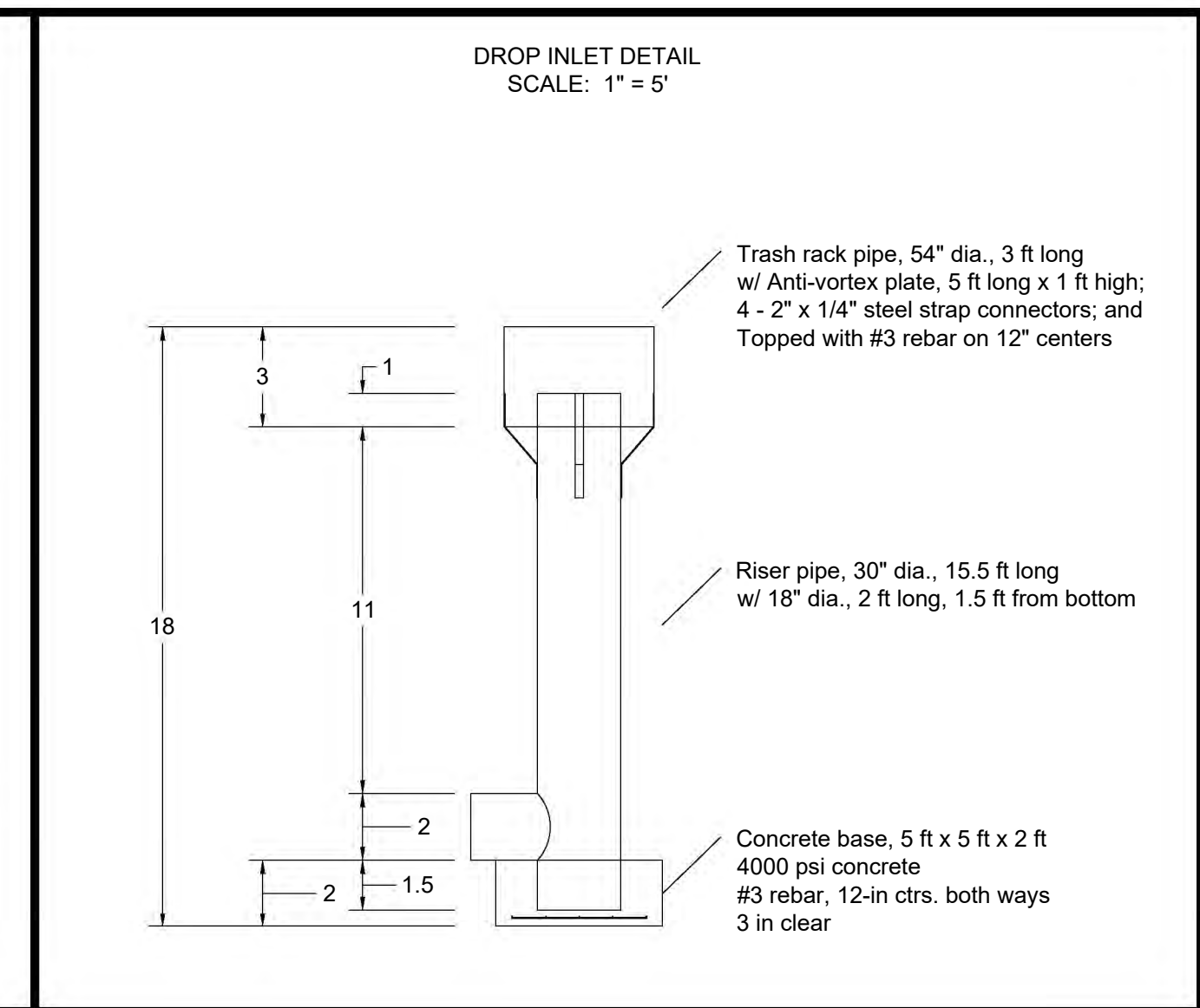
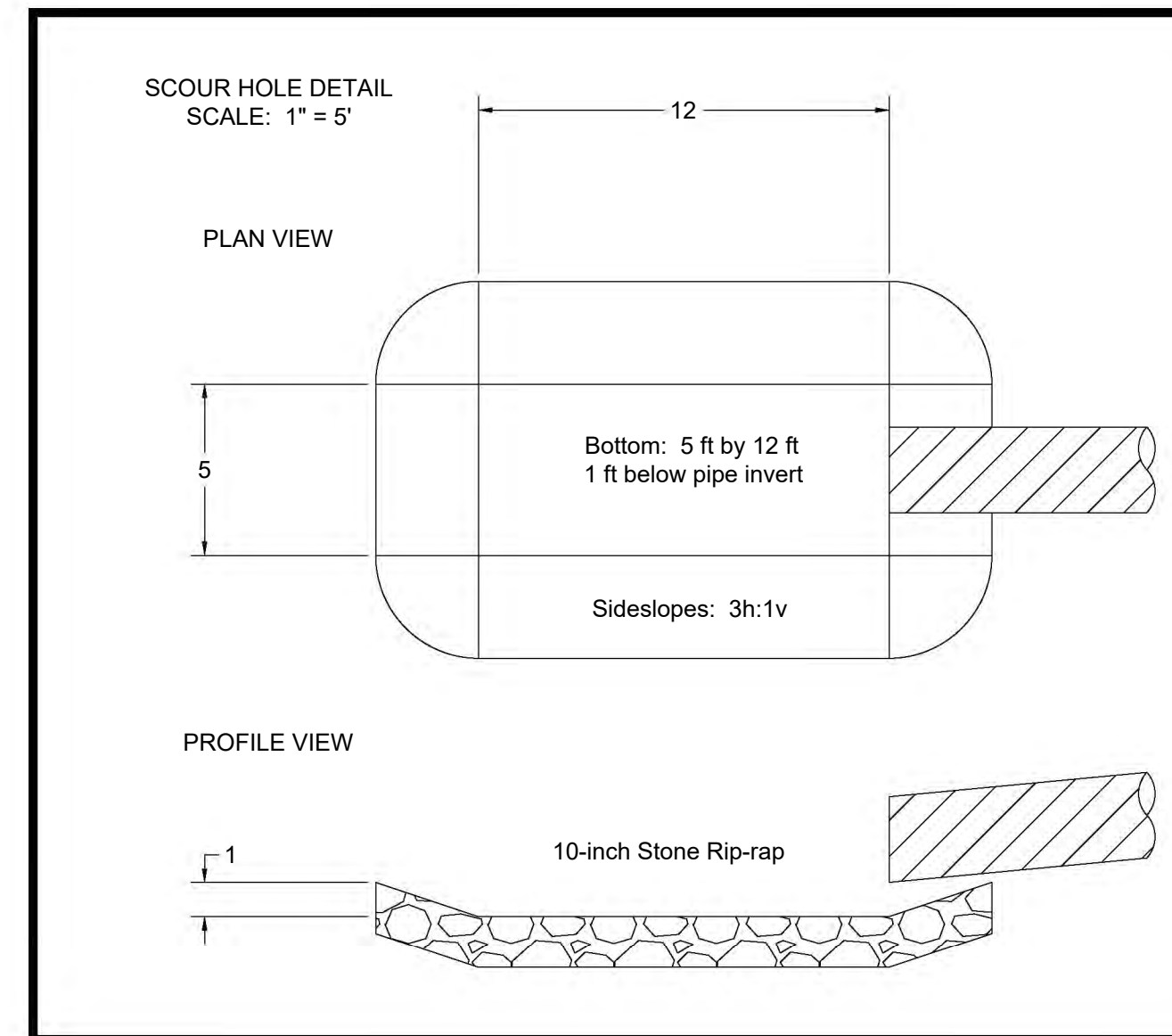
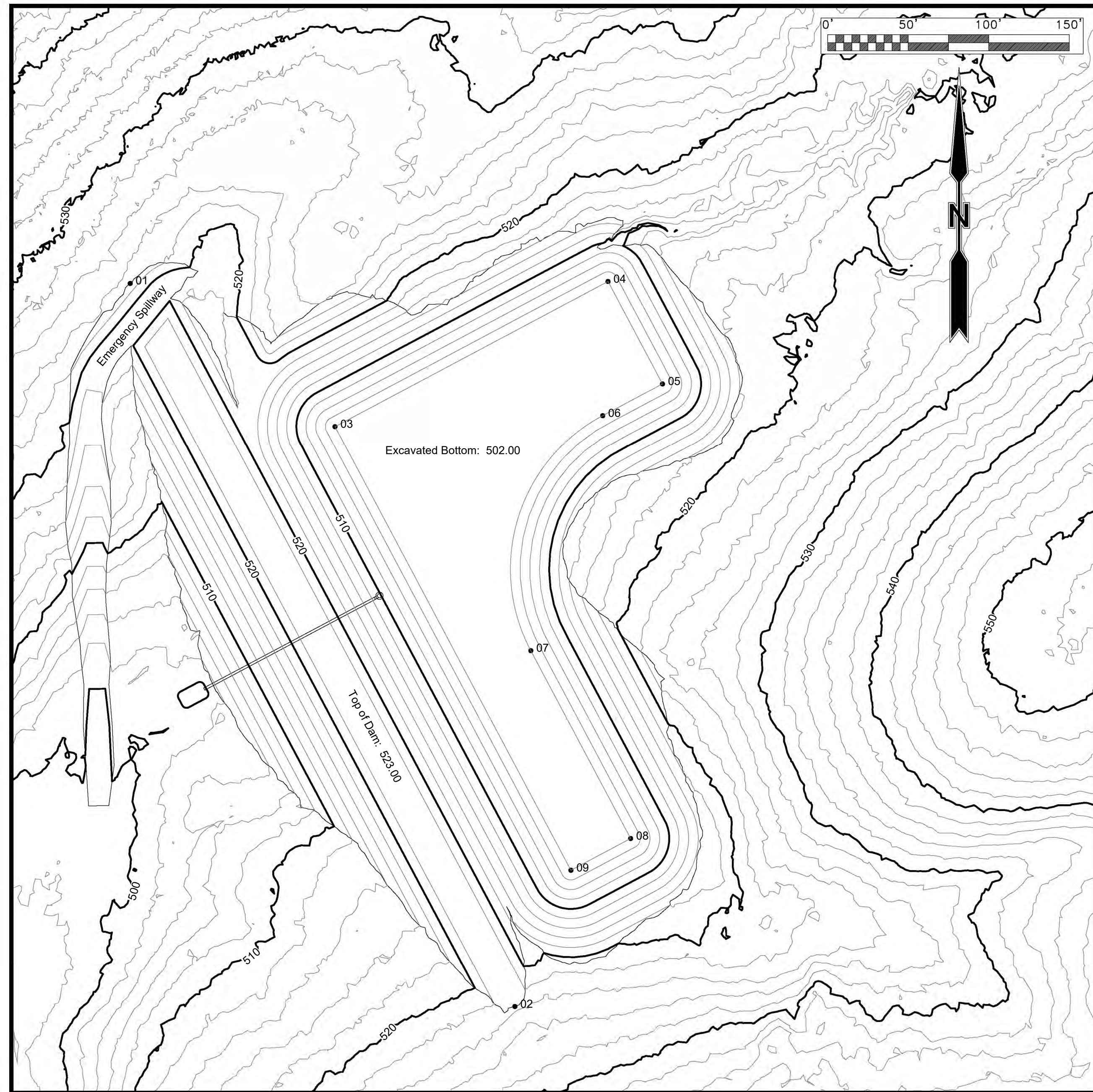

CONTROL POINTS
State Plane, Alabama West, Feet

Point	East	North	Elevation
01	2,063,176.87	1,164,848.22	523.00
02	2,063,415.71	1,164,399.02	523.00

CENTERLINE OF DAM

Point	East	North	Elevation
03	2,063,304.00	1,164,759.28	502.00
04	2,063,473.53	1,164,849.42	502.00
05	2,063,507.33	1,164,785.85	502.00
06	2,063,470.25	1,164,766.13	502.00

POND EXCAVATION

Point	East	North	Elevation
07	2,063,425.59	1,164,620.07	502.00
08	2,063,487.56	1,164,503.52	502.00
09	2,063,450.48	1,164,483.80	502.00

Radius = 108.00

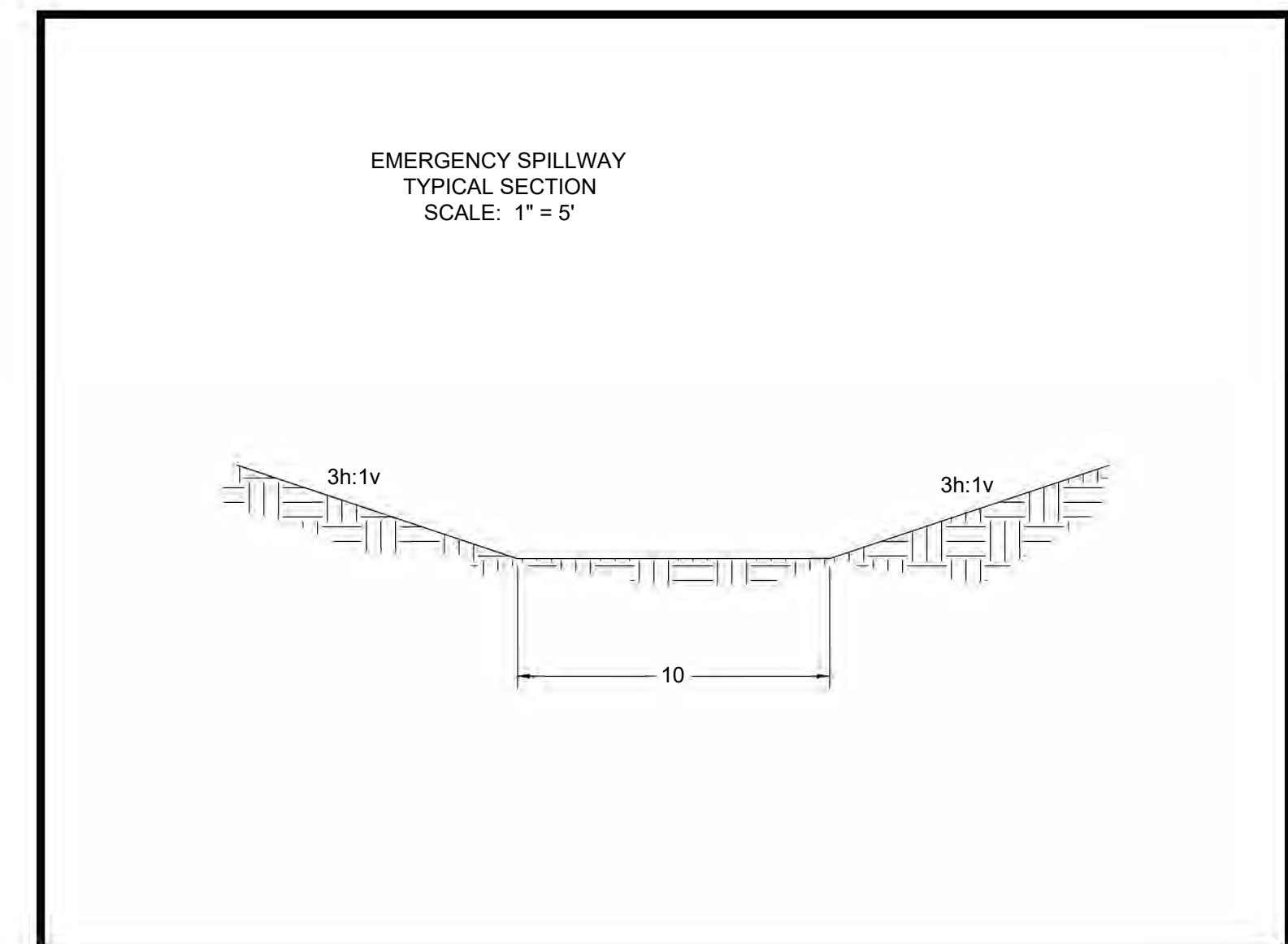

INSITE ENGINEERING
5800 FELDSPAR WAY
HOOVER, ALABAMA 35244
OFFICE (205) 733-8686
FAX (205) 733-9697

2135 UNIVERSITY BLVD, SUITE A
OFFICE (205) 752-4037
FAX (205) 722-2246

CIVIL / GIS
INFRASTRUCTURE
ENVIRONMENTAL
PLANNING
COMMERCIAL
RESIDENTIAL

Vance Pit
Pond 003

Davis Materials, Inc., Tuscaloosa, AL 35403

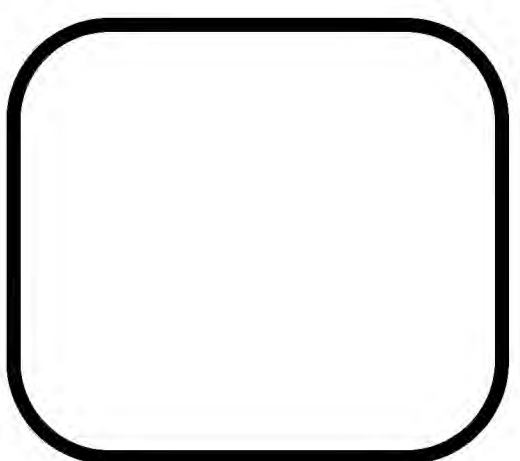

PROJECT INFO:
INSITE JOB No. 21103.00
PLOTTED: NA

THIS SHEET CONTAINS:
SHEET TITLE
Vance Pit
Pond 003

SCALE: Varies
SHEET 1 OF 1

01

8. Forms

8.1. Introduction

The ADEM forms associated with the application are included in this chapter.

**ALABAMA DEPARTMENT OF ENVIRONMENTAL MANAGEMENT (ADEM)
NPDES INDIVIDUAL PERMIT APPLICATION (MINING OPERATIONS)**

Instructions: This form should be used to submit an application for an NPDES individual permit to authorize discharges from surface & underground mineral, ore, or mineral product mining, quarrying, excavation, borrowing, hydraulic mining, storage, processing, preparation, recovery, handling, loading, storing, or disposing activities, and associated areas including pre-mining site development, construction, excavation, clearing, disturbance, and reclamation. Please complete all questions. Respond with "N/A" as appropriate. Incomplete or incorrect answers or missing signatures will delay processing. Attach additional comments or information as needed. If space is insufficient, continue on an attached sheet(s) as necessary. Commencement of activities applied for as detailed in this application are not authorized until permit coverage has been issued by the Department. Please type or print legibly in blue or black ink.

PURPOSE OF THIS APPLICATION

- Initial Permit Application for New Facility
 Initial Permit Application for Existing Facility (e.g. facility previously permitted less than 5 acres)
 Modification of Existing Permit
 Reissuance of Existing Permit
 Reissuance & Modification Existing Permit
 Reissuance & Transfer of Existing Permit
 Revocation and Reissuance of Existing Permit
 Other

I. GENERAL INFORMATION

NPDES Permit Number (Not applicable if initial permit application): <i>AL 0083917</i>	County(s) in which Facility is Located: <i>Tuscaloosa, Bibb</i>
--	--

Company/Permittee Name: <i>Davis Materials, Inc.</i>		Facility Name (e.g., Mine Name, Pit Name, etc.): <i>Vance Pit</i>	
Mailing Address of Company/Permittee: <i>P.O. Box 1099</i>		Physical Address of Facility (as near as possible to entrance): <i>Story Road</i>	
City: <i>Tuscaloosa</i>	State: <i>AL</i>	Zip: <i>35403</i>	City: <i>Vance</i>
			State: <i>AL</i>
			Zip: <i>35490</i>
Permittee Phone Number: <i>(205) 345-6622</i>	Permittee Fax Number:	Latitude and Longitude of entrance: <i>33.2060°, -87.1871°</i>	

Responsible Official (as described on page 12 of this application): <i>Chris H. Davis</i>		Responsible Official Title: <i>President</i>	
Mailing Address of Responsible Official: <i>P.O. Box 1099</i>		Physical Address of Responsible Official: <i>1608 17th Street</i>	
City: <i>Tuscaloosa</i>	State: <i>AL</i>	Zip: <i>35403</i>	City: <i>Tuscaloosa</i>
			State: <i>AL</i>
			Zip: <i>35401</i>
Phone Number of Responsible Official: <i>(205) 345-6622</i>	Fax Number of Responsible Official: <i>(205) 750-0209</i>	Email Address of Responsible Official: <i>cdavis@bamaconcrete.com</i>	

Facility Contact: <i>Ronald T. Davis</i>		Facility Contact Title: <i>Vice-President</i>	
Physical Address of Facility Contact: <i>1608 17th Street</i>		Phone Number of Facility Contact: <i>(205) 345-6622</i>	Fax Number of Facility Contact: <i>(205) 750-0209</i>
City: <i>Tuscaloosa</i>	State: <i>AL</i>	Zip: <i>35401</i>	Email Address of Facility Contact: <i>tdavis@bamaconcrete.com</i>

II. MEMBER INFORMATION

A. Identify the name, title/position, and unless waived in writing by the Department, the residence address of every officer, general partner, LLP partner, LLC member, investor, director, or person performing a function similar to a director, of the applicant, and each person who is the record or beneficial owner of 10 percent or more of any class of voting stock of the applicant, or any other responsible official(s) of the applicant with legal or decision making responsibility or authority for the facility:

Name:	Title/Position:	Physical Address of Residence (P.O. Box is Not Acceptable)
<u>Chris H. Davis</u>	<u>President</u>	<u>14393 Sterling Lane Northport, AL 35475</u>
<u>Ronald T. Davis</u>	<u>Vice-President</u>	<u>10788 Lunceford Road Northport, AL 35475</u>

B. Other than the "Company/Permittee" listed in Part I., identify the name of each corporation, partnership, association, and single proprietorship for which any individual identified in Part II.A. is or was an officer, general partner, LLP partner, LLC member, investor, director, or individual performing a function similar to a director, or principal (10% or more) stockholder, that had an Alabama NPDES permit at any time during the five year (60 month) period immediately preceding the date on which this form is signed:

Name of Corporation, Partnership, Association, or Single Proprietorship:	Name of Individual from Part II.A.:	Title/Position in Corporation, Partnership, Association, or Single Proprietorship:
<u>Bama Concrete Products Co., Inc.</u>	<u>Ronald T. (Tyler) Davis</u>	<u>Vice-President</u>

III. LEGAL STRUCTURE OF APPLICANT

A. Indicate the legal structure of the "Company/Permittee" listed in Part I:

Corporation
 Association
 Individual
 Single Proprietorship
 Partnership
 LLP
 LLC
 Government Agency: _____ Other: _____

B. If not an individual or single proprietorship, is the "Company/Permittee" listed in Part I. properly registered and in good standing with the Alabama Secretary of State's Office? (If the answer is "No," attach a letter of explanation.) Yes No

C. Parent Corporation and Subsidiary Corporations of Applicant, if any: N/A

D. Land Owner(s): Warrior of Arkansas, Inc.; Abbott Road Properties, LLC; Davis Hauling, LLC

E. Mining Sub-contractor(s)/Operator(s), if known: N/A

IV. COMPLIANCE HISTORY

A. Has the applicant ever had any of the following:

	Yes	No
(1) An Alabama NPDES, SID, or UIC permit suspended or terminated?	<input type="checkbox"/>	<input checked="" type="checkbox"/>
(2) An Alabama license to mine suspended or revoked?	<input type="checkbox"/>	<input checked="" type="checkbox"/>
(3) An Alabama or federal mining permit suspended or terminated?	<input type="checkbox"/>	<input checked="" type="checkbox"/>
(4) A reclamation bond, or similar security deposited in lieu of a bond, or portion thereof, forfeited?	<input type="checkbox"/>	<input checked="" type="checkbox"/>
(5) A bond or similar security deposited in lieu of a bond, or portion thereof, the purpose of which was to secure compliance with any requirement of the Alabama Water Improvement Commission or Alabama Department of Environmental Management, forfeited?	<input type="checkbox"/>	<input checked="" type="checkbox"/>

(If the response to any item of Part IV.A. is "Yes," attach a letter of explanation.)

B. Identify every Warning Letter, Notice of Violation (NOV), Administrative Action, or litigation issued to the applicant, parent corporation, subsidiary, general partner, LLP partner, or LLC member and filed by ADEM or EPA during the three year (36 months) period preceding the date on which this form is signed. Indicate the date of issuance, briefly describe alleged violations, list actions (if any) to abate alleged violations, and indicate date of final resolution:

None

V. OTHER PERMITS/AUTHORIZATIONS

A. List any other NPDES or other environmental permits (including permit numbers), authorizations, or certifications that have been applied for or issued within the State by ADEM, EPA, Alabama Surface Mining Commission (ASMC), Alabama Department of Labor (ADOL), US Army Corp of Engineers (USACE), or other agency, to the applicant, parent corporation, subsidiary, or LLC member for this facility whether presently effective, expired, suspended, revoked, or terminated:

None

B. List any other NPDES or other ADEM permits (including permit numbers), authorizations, or certifications that have been applied for or issued within the State by ADEM, EPA, ASMC, ADOL or USACE, to the applicant, parent corporation, subsidiary, or LLC member for other facilities whether presently effective, expired, suspended, revoked, or terminated:

10411 Bama Concrete Products Inc. -- Northport Plant; ALG110372 Bama Concrete Products, Inc. -- Bessemer; ALG110299 Bama Concrete Inc. -- Woodstock; ALG110342 Bama Concrete Products Inc. -- Brent; AL11021 Bama Concrete Products Inc. -- Tuscaloosa; ALG850070 Concrete Products Company, Inc. dba Davis Sand and Gravel -- Cypress Pit

VI. PROPOSED SCHEDULE

Anticipated Activity Commencement Date: April 2020 Anticipated Activity Completion Date: 2030

VII. ACTIVITY DESCRIPTION & INFORMATION

A. Proposed Total Area of the Permitted Site: 137 acres Proposed Total Disturbed Area of the Permitted Site: 89 acres

B. Township(s), Range(s), Section(s): T21S, R6W, S17 & 20

C. Detailed Directions to Site: **Begin at the intersection of US-11 and AL-5 in Woodstock. Travel south on US-11 for 1.6 miles to Story Road and turn right. The pit is less than one mile from US-11.**

D. Is/ will this facility:

- | | Yes | No |
|---|-------------------------------------|-------------------------------------|
| (1) an existing facility which currently results in discharges to State waters? | <input checked="" type="checkbox"/> | <input type="checkbox"/> |
| (2) a proposed facility which will result in a discharge to State waters? | <input type="checkbox"/> | <input checked="" type="checkbox"/> |
| (3) be located within any 100-year flood plain? | <input checked="" type="checkbox"/> | <input type="checkbox"/> |
| (4) discharge to Municipal Separate Storm Sewer? | <input type="checkbox"/> | <input checked="" type="checkbox"/> |
| (5) discharge to waters of or be located in the Coastal Zone? | <input type="checkbox"/> | <input checked="" type="checkbox"/> |
| (6) need/have ADEM UIC permit coverage? | <input type="checkbox"/> | <input checked="" type="checkbox"/> |
| (7) be located on Indian/ historically significant lands? | <input type="checkbox"/> | <input checked="" type="checkbox"/> |
| (8) need/have ADEM SID permit coverage? | <input type="checkbox"/> | <input checked="" type="checkbox"/> |
| (9) need/have ASMC permit coverage? | <input type="checkbox"/> | <input checked="" type="checkbox"/> |
| (10) need/have ADOL permit coverage? | <input type="checkbox"/> | <input checked="" type="checkbox"/> |
| (11) generate, treat, store, or dispose of hazardous or toxic waste ? (If "Yes," attach a detailed explanation.) | <input type="checkbox"/> | <input checked="" type="checkbox"/> |
| (12) be located in or discharge to a Public Water Supply (PWS) watershed or be located within 1/2 mile of any PWS well? | <input type="checkbox"/> | <input checked="" type="checkbox"/> |

VIII. MATERIAL TO BE REMOVED, PROCESSED, OR TRANSLOADED

List relative percentages of the mineral(s) or mineral product(s) that are proposed to be and/or are currently mined, quarried, recovered, prepared, processed, handled, transloaded, or disposed at the facility. **If more than one mineral is to be mined, list the relative percentages of each mineral by tonnage for the life of the mine.**

___ Dirt &/or Chert	___ Sand &/or Gravel	___ Chalk	___ Talc	<u>5</u> Crushed rock (other)
___ Bentonite	___ Industrial Sand	___ Marble	___ Shale &/or Common Clay	___ Sandstone
___ Coal	___ Kaolin	___ Coal fines/refuse recovery	___ Coal product, coke	___ Slag, Red Rock
___ Fire clay	___ Iron ore	___ Dimension stone	___ Phosphate rock	___ Granite
___ Bauxitic Clay	___ Bauxite Ore	<u>95</u> Limestone, crushed limestone and dolomite		
___ Gold, other trace minerals: _____		___ Other: _____		
___ Other: _____		___ Other: _____		
___ Other: _____		___ Other: _____		

IX. PROPOSED ACTIVITY TO BE CONDUCTED

- A. Type(s) of activity presently conducted at applicant's existing facility or proposed to be conducted at facility (check all that apply):
- Surface mining Underground mining Quarrying Auger mining Hydraulic mining
 - Within-bank mining Solution mining Mineral storing Lime production Cement production
 - Synthetic fuel production Alternative fuels operation Mineral dry processing (crushing & screening) Mineral wet preparation
 - Other beneficiation & manufacturing operations Mineral loading Chemical processing or leaching
 - Construction related temporary borrow pits/areas Mineral transportation rail barge truck
 - Preparation plant waste recovery Hydraulic mining, dredging, instream or between stream-bank mining
 - Grading, clearing, grubbing, etc. Pre-construction ponded water removal Excavation
 - Pre-mining logging or land clearing Waterbody relocation or other alteration Creek/stream crossings
 - Onsite construction debris or equipment storage/disposal Onsite mining debris or equipment storage/disposal
 - Reclamation of disturbed areas Chemicals used in process or wastewater treatment (coagulant, biocide, etc.)
 - Adjacent/associated asphalt/concrete plant(s) Low volume sewage treatment package plant
 - Other: _____
- B. Primary SIC Code: 1422 NAICS Code: 212312 Description: Crushed & Broken Limestone (includes Dolomite)
 Secondary SIC Code(s): _____ NAICS Code: _____ Description: _____
- C. Narrative Description of the Activity: The Vance Pit of Davis Materials, Inc. will produce crushed stone aggregate for commercial use.

X. FUEL – CHEMICAL HANDLING, STORAGE & SPILL PREVENTION CONTROL & COUNTERMEASURES (SPCC) PLAN

- A. Will fuels, chemicals, compounds, or liquid waste be used or stored onsite? Yes No
- B. If "Yes," identify the fuel, chemicals, compounds, or liquid waste and indicate the volume of each:
- | Volume | Contents | Volume | Contents | Volume | Contents |
|---------------------|---------------|---------------|----------|---------------|----------|
| <u>1000</u> gallons | <u>Diesel</u> | _____ gallons | _____ | _____ gallons | _____ |
| <u>1000</u> gallons | <u>Diesel</u> | _____ gallons | _____ | _____ gallons | _____ |
- C. If "Yes," a detailed SPCC Plan with acceptable format and content, including diagrams, must be attached to application in accordance with ADEM Admin. Code R. 335-6-6-.12(r). Unless waived in writing by the Department on a programmatic, categorical, or individual compound/chemical basis, Material Safety Data Sheets (MSDS) for chemicals/compounds used or proposed to be used at the facility must be included in the SPCC Plan submittal.

XI. POLLUTION ABATEMENT & PREVENTION (PAP) PLAN

- A. For non-coal mining facilities, a PAP Plan in accordance with ADEM Admin. Code r. 335-6-9-.03 has been completed and is attached as part of this application. Yes No
- B. For coal mining facilities, a detailed PAP Plan has been submitted to ASMC according to submittal procedures for ASMC regulated facilities. Yes No
- (1) If "Yes" to Part XI.B., provide the date that the PAP Plan was submitted to ASMC: N/A
- (2) If "No" to Part XI.B., provide the anticipated date that the PAP Plan will be submitted to ASMC: N/A

XII. ASMC REGULATED ENTITIES

- A. Is this coal mining operation regulated by ASMC? Yes No
- B. If "Yes", provide copies as part of this application of any pre-mining hydrologic sampling reports and Hydrologic Monitoring Reports which have been submitted to ASMC within the 36 months prior to submittal of this application.

XIII. TOPOGRAPHIC MAP SUBMITTAL

Attach to this application a 7.5 minute series U.S.G.S. topographic map(s) or equivalent map(s) no larger than, or folded to a size of 8.5 by 11 inches (several pages may be necessary), of the area extending to at least one mile beyond property boundaries. The topographic or equivalent map(s) must include a caption indicating the name of the topographic map, name of the applicant, facility name, county, and township, range, & section(s) where the facility is located. Unless approved in advance by the Department, the topographic or equivalent map(s), at a minimum, must show:

- (a) An accurate outline of the area to be covered by the permit
- (b) An outline of the facility
- (c) All existing and proposed disturbed areas
- (d) Location of discharge areas
- (e) Proposed and existing discharge points
- (f) Perennial, intermittent, and ephemeral streams
- (g) Lakes, springs, water wells, wetlands
- (h) All known facility dirt/improved access/haul roads
- (i) All surrounding unimproved/improved roads
- (j) High-tension power lines and railroad tracks
- (k) Buildings and structures, including fuel/water tanks
- (l) Contour lines, township-range-section lines
- (m) Drainage patterns, swales, washes
- (n) All drainage conveyance/treatment structures (ditches, berms, etc.)
- (o) Any other pertinent or significant feature

XIV. DETAILED FACILITY MAP SUBMITTAL

Attach to this application a 1:500 scale or better, detailed auto-CAD map(s) or equivalent map(s) no larger than, or folded to a size of 8.5 by 11 inches (several pages may be necessary), of the facility. The facility map(s) must include a caption indicating the name of the facility, name of the applicant, facility name, county, and township, range, & section(s) where the facility is located. Unless approved in advance by the Department, the facility or equivalent map(s), at a minimum, must show:

- (a) Information listed in Item XIII (a) – (o) above
- (b) If noncoal, detailed, planned mining progression
- (c) If noncoal, location of topsoil storage areas
- (d) Location of ASMC bonded increments (if applicable)
- (e) Location of mining or pond cleanout waste storage/disposal areas
- (f) Other information relevant to facility or operation
- (g) Location of facility sign showing Permittee name, facility name, and NPDES Number

XV. RECEIVING WATERS

List the requested permit action for each outfall (issue, reissue, add, delete, move, etc.), outfall designation including denoting “E” for existing and “P” for proposed outfalls, name of receiving water(s), whether or not the stream is included in a TMDL, latitude and longitude (to seconds) of location(s) of each discharge point, distance of receiving water from outfall in feet, number of disturbed acres, the number of drainage acres which will drain through each treatment system, outfall, or BMP, and if the outfall discharges to an ADEM listed CWA Section 303(d) waterbody segment at the time of application submittal.

Action	Outfall E/P	Receiving Water	Latitude	Longitude	Distance to Rec. Water	Disturbed Acres	Drainage Acres	ADEM WUC	303(d) Segment (Y/N)	TMDL Segment* (Y/N)
Reissue	001E	Banks Creek	33.2090°	-87.1902°	40 ft	9	37	F/W	N	N
Reissue	002E	Banks Creek	33.2053°	-87.1924°	40 ft	0	21	F/W	N	N
Issue	003P	UT to Banks Creek	33.2012°	-87.1908°	40 ft	63	68	F/W	N	N

*If a TMDL Compliance Schedule is requested, the following should be attached as supporting documentation: (1) Justification for the requested Compliance Schedule (e.g. time for design and installation of control equipment, etc.); (2) Monitoring results for the pollutant(s) of concern which have not previously been submitted to the Department (sample collection dates, analytical results (mass and concentration), methods utilized, MDL/ML, etc. should be reported as available); (3) Requested interim limitations, if applicable; (4) Date of final compliance with the TMDL limitations; and (5) Any other additional information available to support the requested compliance schedule.

XVI. DISCHARGE CHARACTERIZATION

A. EPA Form 2C, EPA Form 2D, and/or Modified EPA Form 2C Submittal

Yes, pursuant to 40 CFR §122.21, the applicant requests a waiver for completion of EPA Form 2C, EPA Form 2D, and the modified EPA Form 2C and certifies that the operating facility will discharge treated stormwater only, unless waived in writing by the Department on a programmatic, categorical, or individual compound/chemical basis that chemical/compound additives are not used, and that there are no process, manufacturing, or other industrial operations or wastewaters, including but not limited to lime or cement production, synfuel operations, *etc.*, and that coal and coal products are not mined nor stored onsite.

No, the applicant does not request a waiver and a complete EPA Form 2C, EPA Form 2D, and/or modified EPA Form 2C is attached.

B. The applicant is required to supply the following information separately for every P or E outfall. If necessary, attach extra sheets. List expected average daily discharge flow rate in cfs and gpd, frequency of discharge in hours per day and days per month, average summer and winter temperature of discharge(s) in degrees centigrade (C), average pH in standard units, average daily discharge in pounds per day of BOD₅, Total Suspended Solids, Total Iron, Total Manganese, and Total Aluminum (if bauxite or bauxitic clay):

Outfall E/P	Information Source - # of Samples	Flow cfs	Flow gpd	Frequency hours/day	Frequency days/month	Sum/Win Temp, °C	pH s.u.	BOD ₅ lbs/day	TSS lbs/day	Tot Fe lbs/day	Tot Mn lbs/day	Tot Al lbs/day
001E	BPE	0.11	74,000	24	30	21 / 19	7.5	1.2	4.3	0.12	0.01	NA
002E	BPE	0.06	42,000	24	30	21 / 19	7.5	0.4	3.5	0.07	0.00	NA
003P	BPE	0.21	136,000	24	30	21 / 19	7.5	2.3	7.9	0.23	0.02	NA

C. The applicant is required to supply the following information separately for every P or E outfall. If necessary, attach extra sheets. Identify and list expected average daily discharge in pounds per day of any other pollutant(s) listed in EPA Form 2C, Item V – Intake And Effluent Characteristics, Parts A, B, & C that are not referenced in Part XV.B., that you know is present or have reason to believe could be present in the discharge(s) at levels of concern:

Outfall E/P	Reason Believed Present	Information Source - # of Samples									
			lbs/day	lbs/day	lbs/day	lbs/day	lbs/day	lbs/day	lbs/day	lbs/day	lbs/day

XVII. DISCHARGE STRUCTURE DESCRIPTION & POLLUTANT SOURCE

The applicant is required to supply outfall number(s) as it appears on the map(s) required by this application [if this application is for a modification to an existing permit do not change the numbering sequence of the permitted outfalls], describe each, (e.g., pipe, spillway, channel, tunnel, conduit, well, discrete fissure, or container), and identify the origin of pollutants. The response must be precise for each outfall. If the discharge of pollutants from any outfall is the result of commingling of waste streams from different origins, each origin must be completely described.

Outfall	Discharge structure Description	Description of Origin of pollutants	Surface Discharge	Groundwater Discharge	Wet Prep -Other Production Plant	Pumped or Controlled Discharge	Low Volume STP	Other
001E	Pipe	7, 8, 9, 10, 11	Yes	No	Yes	Yes	No	NA
002E	Pipe	7, 8, 9, 10, 11	Yes	No	No	Yes	No	NA
003P	Pipe	7, 8, 9, 10, 11	Yes	No	No	Yes	No	NA

Origin of Pollutants – typical examples:

(1) Discharge of drainage from the underground workings of an underground coal mine, **(2)** Discharge of drainage from a coal surface mine, **(3)** Discharge of drainage from a coal preparation plant and associated areas, **(4)** Discharge of process wastewater from a gravel-washing plant, **(5)** Discharge of wastewater from an existing source coal preparation plant, **(6)** Discharge of drainage from a sand and gravel pit, **(7)** Pumped discharge from a limestone quarry, **(8)** Controlled surface mine drainage (pumped or siphoned), **(9)** Discharge of drainage from mine reclamation, or **(10) Other** (describe below).

- 10. Discharge of drainage from an aggregate pit.
- 11. Runoff from an aggregate crushing & sizing processing area.
- 12. Runoff from a construction site.

XVIII. PROPOSED NEW OR INCREASED DISCHARGES

A. Pursuant to ADEM Admin. Code Chapter 335-6-10-.12(9), responses to the following questions must be provided by the applicant requesting NPDES permit coverage for new or expanded discharges of pollutant(s) to Tier 2 waters (except discharges eligible for coverage under general permits). As part of the permit application review process, the Department is required to consider, based on the applicant's demonstration, whether the proposed new or increased discharge to Tier 2 waters is necessary for important economic or social development in the area in which the waters are located.

Yes. New/increased discharges of pollutant(s) or discharge locations to Tier 2 waters are proposed.

No. New/increased discharges of pollutants(s) or discharge locations to Tier 2 waters are not proposed.

B. If "Yes," complete Items 1 through 6 of this Part (XVII.B.), ADEM Form 311-Alternative Analysis, and either ADEM Form 312 or ADEM Form 313-Calculation of Total Annualized Project Costs (Public-Section or Private-Sector, whichever is applicable). ADEM Form 312 or ADEM Form 313, whichever, is applicable, should be completed for each technically feasible alternative evaluated on ADEM Form 311. ADEM Forms can be found on the Department's website at www.adem.alabama.gov/DeptForms. **Attach additional sheets/documentation and supporting information as needed.**

(1) What environmental or public health problem will the discharge be correcting?

None.

(2) How much will the discharger be increasing employment (at its existing facility or as a result of locating a new facility)?

Increased employment by 5 employees.

(3) How much reduction in employment will the discharger be avoiding?

None.

(4) How much additional state or local taxes will the discharger be paying?

The following amounts have been estimated: Income tax withheld from and paid on employees, \$20,000; tax on company, \$25,000; real estate tax, \$3,000; sales/use tax, \$5,000; personal property tax, \$5,000; business license tax, \$1,000. The equipment used to mine and process the materials use energy. Taxes are also paid on the energy. For example, almost half of the cost of diesel or gasoline is tax. The estimated fuel tax is \$4,200. In addition to the direct taxes paid, numerous support facilities and vendors also pay taxes.

(5) What public service to the community will the discharger be providing?

The discharger plans to be a cohesive part of the local community of Tuscaloosa and expects to be a contributing part of the Vance and Woodstock communities. Community relations and development is a major goal of the facility. Local organizations and charities will be provided with contributions from Davis Materials, LLC through various projects. An additional public service provided to the community includes environmental protection for Banks Creek, a water of the state designated for fish and wildlife habitat. Preventing pollution to Bank Creek will provide the ability to preserve the water of the state for current and future area residences. Of course, the money provided to employees, the taxes paid to government, and the production of stone aggregate all have the potential to lead to public service to the community.

(6) What economic or social benefit will the discharger be providing to the community?

Obviously, employment provides very important economic and social benefits to the community. The discharger will employ people from Tuscaloosa and the surrounding communities. In addition to the direct employment, the discharger creates indirect economic social benefits through other companies that provide support services. The Vance Pit will provide material for construction projects. The construction projects could result in improved infrastructure could be a critical part of economic growth within the region. The company will make charitable contributions. Employees also make charitable contributions, including church tithes.

XIX. POLLUTION ABATEMENT & PREVENTION (PAP) PLAN SUMMARY (must be completed for all outfalls)

Y	N	N/A	Outfall(s): 001E
X			Runoff from all areas of disturbance is controlled
X			Drainage from pit area, stockpiles, and spoil areas directed to a sedimentation pond
X			Sedimentation basin at least 0.25 acre/feet for every acre of disturbed drainage
X			Sedimentation basin cleaned out when sediment accumulation is 60% of design capacity
X			Trees, boulders, and other obstructions removed from pond during initial construction
X			Width of top of dam greater than 12'
X			Side slopes of dam no steeper than 3:1
X			Cutoff trench at least 8' wide
X			Side slopes of cutoff trench no less than 1:1
X			Cutoff trench located along the centerline of the dam
X			Cutoff trench extends at least 2' into bedrock or impervious soil
X			Cutoff trench filled with impervious material
X			Embankments and cutoff trench 95% compaction standard proctor ASTM
X			Embankment free of roots, tree debris, stones >6" diameter, etc.
X			Embankment constructed in lifts no greater than 12"
X			Spillpipe sized to carry peak flow from a one year storm event
X			Spillpipe will not chemically react with effluent
X			Subsurface withdrawal
X			Anti-seep collars extend radially at least 2' from each joint in spillpipe
X			Splashpad at the end of the spillpipe
X			Emergency Spillway sized for peak flow from 25-yr 24-hr event if discharge not into PWS classified stream
		X	Emergency spillway sized for peak flow from 50-yr 24-hr event if discharge is into PWS classified stream
X			Emergency overflow at least 20' long
X			Side slopes of emergency spillway no steeper than 2:1
X			Emergency spillway lined with riprap or concrete
X			Minimum of 1.5' of freeboard between normal overflow and emergency overflow
X			Minimum of 1.5' of freeboard between max. design flow of emergency spillway and top of dam
X			All emergency overflows are sized to handle entire drainage area for ponds in series
X			Dam stabilized with permanent vegetation
X			Sustained grade of haul road <10%
X			Maximum grade of haul road <15% for no more than 300'
X			Outer slopes of haul road no steeper than 2:1
X			Outer slopes of haul road vegetated or otherwise stabilized
		X	Detail drawings supplied for all stream crossings
X			Short-Term Stabilization/Grading And Temporary Vegetative Cover Plans
X			Long-Term Stabilization/Grading And Permanent Reclamation or Water Quality Remediation Plans

IDENTIFY AND PROVIDE DETAILED EXPLANATION FOR ANY "N" OR "N/A" RESPONSE(s):

No PWS classified stream
 Emergency spillway is not used during design event. If emergency spillway is used, low velocities are expected. Grass is suitable.
 Initially, no stream crossings are proposed. If a future stream crossing becomes necessary then an application for permit modification will be prepared.

XIX. POLLUTION ABATEMENT & PREVENTION (PAP) PLAN SUMMARY (must be completed for all outfalls)

Y	N	N/A	Outfall(s): 002E
X			Runoff from all areas of disturbance is controlled
X			Drainage from pit area, stockpiles, and spoil areas directed to a sedimentation pond
X			Sedimentation basin at least 0.25 acre/feet for every acre of disturbed drainage
X			Sedimentation basin cleaned out when sediment accumulation is 60% of design capacity
X			Trees, boulders, and other obstructions removed from pond during initial construction
X			Width of top of dam greater than 12'
X			Side slopes of dam no steeper than 3:1
X			Cutoff trench at least 8' wide
X			Side slopes of cutoff trench no less than 1:1
X			Cutoff trench located along the centerline of the dam
X			Cutoff trench extends at least 2' into bedrock or impervious soil
X			Cutoff trench filled with impervious material
X			Embankments and cutoff trench 95% compaction standard proctor ASTM
X			Embankment free of roots, tree debris, stones >6" diameter, etc.
X			Embankment constructed in lifts no greater than 12"
X			Spillpipe sized to carry peak flow from a one year storm event
X			Spillpipe will not chemically react with effluent
X			Subsurface withdrawal
X			Anti-seep collars extend radially at least 2' from each joint in spillpipe
X			Splashpad at the end of the spillpipe
X			Emergency Spillway sized for peak flow from 25-yr 24-hr event if discharge not into PWS classified stream
		X	Emergency spillway sized for peak flow from 50-yr 24-hr event if discharge is into PWS classified stream
X			Emergency overflow at least 20' long
X			Side slopes of emergency spillway no steeper than 2:1
X			Emergency spillway lined with riprap or concrete
X			Minimum of 1.5' of freeboard between normal overflow and emergency overflow
X			Minimum of 1.5' of freeboard between max. design flow of emergency spillway and top of dam
X			All emergency overflows are sized to handle entire drainage area for ponds in series
X			Dam stabilized with permanent vegetation
X			Sustained grade of haul road <10%
X			Maximum grade of haul road <15% for no more than 300'
X			Outer slopes of haul road no steeper than 2:1
X			Outer slopes of haul road vegetated or otherwise stabilized
		X	Detail drawings supplied for all stream crossings
X			Short-Term Stabilization/Grading And Temporary Vegetative Cover Plans
X			Long-Term Stabilization/Grading And Permanent Reclamation or Water Quality Remediation Plans

IDENTIFY AND PROVIDE DETAILED EXPLANATION FOR ANY "N" OR "N/A" RESPONSE(s):

No PWS classified stream
Initially, no stream crossings are proposed. If a future stream crossing becomes necessary then an application for permit modification will be prepared.

XIX. POLLUTION ABATEMENT & PREVENTION (PAP) PLAN SUMMARY (must be completed for all outfalls)

Y	N	N/A	Outfall(s): 003P
X			Runoff from all areas of disturbance is controlled
X			Drainage from pit area, stockpiles, and spoil areas directed to a sedimentation pond
X			Sedimentation basin at least 0.25 acre/feet for every acre of disturbed drainage
X			Sedimentation basin cleaned out when sediment accumulation is 60% of design capacity
X			Trees, boulders, and other obstructions removed from pond during initial construction
X			Width of top of dam greater than 12'
X			Side slopes of dam no steeper than 3:1
X			Cutoff trench at least 8' wide
X			Side slopes of cutoff trench no less than 1:1
X			Cutoff trench located along the centerline of the dam
X			Cutoff trench extends at least 2' into bedrock or impervious soil
X			Cutoff trench filled with impervious material
X			Embankments and cutoff trench 95% compaction standard proctor ASTM
X			Embankment free of roots, tree debris, stones >6" diameter, etc.
X			Embankment constructed in lifts no greater than 12"
X			Spillpipe sized to carry peak flow from a one year storm event
X			Spillpipe will not chemically react with effluent
X			Subsurface withdrawal
X			Anti-seep collars extend radially at least 2' from each joint in spillpipe
X			Splashpad at the end of the spillpipe
X			Emergency Spillway sized for peak flow from 25-yr 24-hr event if discharge not into PWS classified stream
		X	Emergency spillway sized for peak flow from 50-yr 24-hr event if discharge is into PWS classified stream
X			Emergency overflow at least 20' long
X			Side slopes of emergency spillway no steeper than 2:1
X			Emergency spillway lined with riprap or concrete
X			Minimum of 1.5' of freeboard between normal overflow and emergency overflow
X			Minimum of 1.5' of freeboard between max. design flow of emergency spillway and top of dam
X			All emergency overflows are sized to handle entire drainage area for ponds in series
X			Dam stabilized with permanent vegetation
X			Sustained grade of haul road <10%
X			Maximum grade of haul road <15% for no more than 300'
X			Outer slopes of haul road no steeper than 2:1
X			Outer slopes of haul road vegetated or otherwise stabilized
		X	Detail drawings supplied for all stream crossings
X			Short-Term Stabilization/Grading And Temporary Vegetative Cover Plans
X			Long-Term Stabilization/Grading And Permanent Reclamation or Water Quality Remediation Plans

IDENTIFY AND PROVIDE DETAILED EXPLANATION FOR ANY "N" OR "N/A" RESPONSE(s):

No PWS classified stream
Initially, no stream crossings are proposed. If a future stream crossing becomes necessary then an application for permit modification will be prepared.

XX. POLLUTION ABATEMENT & PREVENTION (PAP) PLAN REVIEW CHECKLIST

Y	N	N/A
X		
X		
X		

PE Seal with License #
 Name and Address of Operator
 Legal Description of Facility

General Information:

X		
X		
X		
X		
X		

Name of Company
 Number of Employees
 Products to be Mined
 Hours of Operation
 Water Supply and Disposition

Topographic Map:

X		
X		
X		
X		
X		

Mine Location
 Location of Prep Plant
 Location of Treatment Basins
 Location of Discharge Points
 Location of Adjacent Streams

1"- 500' or Equivalent Facility Map:

X		
X		
X		
X		

Drainage Patterns
 Mining Details
 All Roads, Structures Detailed
 All Treatment Structures Detailed

Detailed Design Diagrams:

X		
X		
X		

Plan Views
 Cross-section Views
 Method of Diverting Runoff to Treatment Basins

Narrative of Operations:

X		
X		
X		

Raw Materials Defined
 Processes Defined
 Products Defined

Schematic Diagram:

X		
X		
X		

Points of Waste Origin
 Collection System
 Disposal System

Post Treatment Quantity and Quality of Effluent:

X		
X		
X		
X		

Flow
 Suspended Solids
 Iron Concentration
 pH

Description of Waste Treatment Facility:

X		
X		
X		
X		

Pre-Treatment Measures
 Recovery System
 Expected Life of Treatment Basin
 Schedule of Cleaning and/or abandonment

Other:

X		
X		
X		
X		
X		
X		

Precipitation/Volume Calculations/Diagram Attached
 BMP Plan for Haul Roads
 Measures for Minimizing Impacts to Adjacent Stream i.e., Buffer Strips, Berms, etc.
 Methods for Minimizing Nonpoint Source Discharges
 Facility Closure Plans
 PE Rationale(s) For Alternate Standards, Designs or Plans

IDENTIFY AND PROVIDE DETAILED EXPLANATION FOR ANY "N" OR "N/A" RESPONSE(s):

XXI. INFORMATION

Contact the Department prior to submittal with any questions or to request acceptable alternate content/format. Be advised that you are not authorized to commence regulated activity until this application can be processed, publicly noticed, and approval to proceed is received in writing from the Department.

EPA Form(s) 1 and 2F need not be submitted unless specifically required by the Department. EPA Form(s) 2C and/or 2D are required to be submitted unless the applicant is eligible for a waiver and the Department grants a waiver, or unless the relevant information required by EPA Form(s) 2C and/or 2D are submitted to the Department in an alternative format acceptable to the Department.

Planned/proposed mining sites that are greater than 5 acres, that mine/process coal or metallic mineral/ore, or that have wet or chemical processing, must apply for and obtain coverage under an Individual NPDES Permit prior to commencement of any land disturbance. Such coverage may be requested via this ADEM Form 315.

The applicant is advised to contact:

- (1) The Alabama Surface Mining Commission (ASMC) if coal, coal fines, coal refuse, or other coal related materials are mined, transloaded, processed, *etc.*;
- (2) The Alabama Department of Labor (ADOL) if conducting non-coal mining operations;
- (3) The Alabama Historical Commission for requirements related to any potential historic or culturally significant sites;
- (4) The Alabama Department of Conservation and Natural Resources (ADCNR) for requirements related to potential presence of threatened/endangered species; and
- (5) The US Army Corps of Engineers, Mobile or Nashville Districts, if this project could cause fill to be placed in federal waters or could interfere with navigation.

The Department must be in receipt of a completed version of this form, including any supporting documentation, and the appropriate processing fee [including Greenfield Fee and Biomonitoring & Toxicity Limits fee(s), if applicable], prior to development of a draft NPDES permit. The completed form, supporting documentation, and the appropriate fees must be submitted to:

Water Division
Alabama Department of Environmental Management
Post Office Box 301463
Montgomery, Alabama 36130-1463
Phone: (334) 271-7823
Fax: (334) 279-3051
h2omail@adem.alabama.gov
www.adem.alabama.gov

XXII. PROFESSIONAL ENGINEER (PE) CERTIFICATION

A detailed, comprehensive Pollution Abatement & Prevention (PAP) Plan must be prepared, signed, and certified by a professional engineer (PE), registered in the State of Alabama, and the PE must certify as follows:

“I certify on behalf of the applicant, that I have completed an evaluation of discharge alternatives (Item XVIII) for any proposed new or increased discharges of pollutant(s) to Tier 2 waters and reached the conclusions indicated. I certify under penalty of law that technical information and data contained in this application, and a comprehensive PAP Plan including any attached SPCC plan, maps, engineering designs, etc. acceptable to ADEM, for the prevention and minimization of all sources of pollution in stormwater and authorized related process wastewater runoff has been prepared under my supervision for this facility utilizing effective, good engineering and pollution control practices and in accordance with the provisions of ADEM Admin. Code Division 335-6, including Chapter 335-6-9 and Appendices A & B. If the PAP Plan is properly implemented and maintained by the Permittee, discharges of pollutants can reasonably be expected to be effectively minimized to the maximum extent practicable and according to permit discharge limitations and other permit requirements. The applicant has been advised that appropriate pollution abatement/prevention facilities and structural & nonstructural management practices or Department approved equivalent management practices as detailed in the PAP Plan must be fully implemented and regularly maintained as needed at the facility in accordance with good sediment, erosion, and other pollution control practices, permit requirements, and other ADEM requirements to ensure protection of groundwater and surface water quality.”

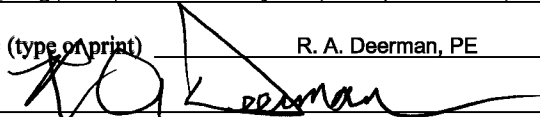
Address <u>Insite Eng., LLC.; 2135 University Blvd, Ste A; Tuscaloosa, AL 35401</u>	PE Registration # <u>16938</u>
Name and Title (type of print) <u>R. A. Deerman, PE</u>	Phone Number <u>(205) 752-4037</u>
Signature 	Date Signed <u>November 01, 2021</u>

XXIII. RESPONSIBLE OFFICIAL SIGNATURE*

This application must be signed by a Responsible Official of the applicant pursuant to ADEM Admin. Code Rule 335-6-6-.09 who has overall responsibility for the operation of the facility.

"I certify under penalty of law that this document, including technical information and data, the PAP Plan, including any SPCC plan, maps, engineering designs, and all other attachments were prepared under my direction or supervision in accordance with a system designed to assure that qualified personnel properly gathered and evaluated the information submitted. Based on my inquiry of the PE and other person or persons under my supervision who manage the system or those persons directly responsible for gathering the information, the information submitted is, to the best of my knowledge and belief, true, accurate, and complete. I am aware that there are significant penalties for submitting false information including the possibility of fine or imprisonment for knowing violations.

"A comprehensive PAP Plan to prevent and minimize discharges of pollution to the maximum extent practicable has been prepared at my direction by a PE for this facility utilizing effective, good engineering and pollution control practices and in accordance with the provisions of ADEM Admin. Code Division 335-6, including Chapter 335-6-9 and Appendices A & B, and information contained in this application, including any attachments. I understand that regular inspections must be performed by, or under the direct supervision of, a PE and all appropriate pollution abatement/prevention facilities and structural & nonstructural management practices or Department approved equivalent management practices identified by the PE must be fully implemented prior to and concurrent with commencement of regulated activities and regularly maintained as needed at the facility in accordance with good sediment, erosion, and other pollution control practices and ADEM requirements. I understand that the PAP Plan must be fully implemented and regularly maintained so that discharges of pollutants can reasonably be expected to be effectively minimized to the maximum extent practicable and according to permit discharge limitations and other requirements to ensure protection of groundwater and surface water quality. I understand that failure to fully implement and regularly maintain required management practices for the protection of groundwater and surface water quality may subject the Permittee to appropriate enforcement action.

"I certify that this form has not been altered, and if copied or reproduced, is consistent in format and identical in content to the ADEM approved form.

"I further certify that the discharges described in this application have been tested or evaluated for the presence of non-stormwater discharges and any non-mining associated beneficiation/process pollutants and wastewaters have been fully identified."

Name (type or print) Chris A Davis

Official Title Pres.

Signature *Chris Davis*

Date Signed 10-18-21

*335-6-6-.09 Signatories to Permit Applications and Reports.

- (1) The application for an NPDES permit shall be signed by a responsible official, as indicated below:
 - (a) In the case of a corporation, by a principal executive officer of at least the level of vice president, or a manager assigned or delegated in accordance with corporate procedures, with such delegation submitted in writing if required by the Department, who is responsible for manufacturing, production, or operating facilities and is authorized to make management decisions which govern the operation of the regulated facility;
 - (b) In the case of a partnership, by a general partner;
 - (c) In the case of a sole proprietorship, by the proprietor; or
 - (d) In the case of a municipal, state, federal, or other public entity by either a principal executive officer, or ranking elected official.