



Alabama Department of Environmental Management
adem.alabama.gov

1400 Coliseum Blvd. 36110-2400 ■ Post Office Box 301463
Montgomery, Alabama 36130-1463
(334) 271-7700 ■ FAX (334) 271-7950

January 2, 2024

Mr. David Langer
Vice President Operations Southern and Gulf Coast
Vulcan Construction Materials, LLC
1200 Urban Center Drive
Birmingham, AL 35242

RE: Draft Permit
Atmore Sand and Gravel
NPDES Permit Number AL0059498
Escambia County (053)

Dear Mr. Langer:

Transmitted herein is a draft of the above referenced permit. Please review the enclosed draft permit carefully. If previously permitted, the draft may contain additions/revisions to the language in your current permit. Please submit any comments on the draft permit to the Department within 30 days from the date of receipt of this letter.

Since the Department has made a tentative decision to reissue the above referenced permit, ADEM Admin. Code r. 335-6-6-.21 requires a public notice of the draft permit followed by a period of at least 30 days for public comment before the permit can be issued. The United States Environmental Protection Agency will also receive the draft permit for review during the 30-day public comment period.

Any mining, processing, construction, land disturbance, or other regulated activity proposed to be authorized by this draft permit is prohibited prior to the effective date of the formal permit. Any mining or processing activity within the drainage basin associated with each permitted outfall which is conducted prior to Departmental receipt of certification from a professional engineer licensed to practice in the State of Alabama, that the Pollution Abatement/Prevention Plan was implemented according to the design plan, or notification from the Alabama Surface Mining Commission that the sediment control structures have been certified, is prohibited.

This permit requires Discharge Monitoring Reports (DMR) to be submitted utilizing the Department's web-based electronic reporting system. Please read Part I.D of the permit carefully and visit <https://aepacs.adem.alabama.gov/nviro/ncore/external/home>.

Should you have any questions concerning this matter, please contact Robert Glover at (334) 271-7975 or robert.glover@adem.alabama.gov.

Sincerely,

William D. McClimans, Chief
Mining and Natural Resource Section
Stormwater Management Branch
Water Division

WDM/rlg File: DPER/4957

cc: Robert Glover, ADEM
Environmental Protection Agency Region IV
Alabama Department of Conservation and Natural Resources
U.S. Fish and Wildlife Service
Alabama Historical Commission
Advisory Council on Historic Preservation
Alabama Department of Labor

Birmingham Branch
110 Vulcan Road
Birmingham, AL 35209-4702
(205) 942-6168
(205) 941-1603 (FAX)

Decatur Branch
2715 Sandlin Road, S.W.
Decatur, AL 35603-1333
(256) 353-1713
(256) 340-9359 (FAX)



Mobile Branch
2204 Perimeter Road
Mobile, AL 36615-1131
(251) 450-3400
(251) 479-2593 (FAX)

Mobile-Coastal
3664 Dauphin Street, Suite B
Mobile, AL 36608
(251) 304-1176
(251) 304-1189 (FAX)



NATIONAL POLLUTANT DISCHARGE ELIMINATION SYSTEM PERMIT

PERMITTEE: Vulcan Construction Materials, LLC
1200 Urban Center Drive
Birmingham, AL 35242

FACILITY LOCATION: Atmore Sand and Gravel
1090 Old Jack Springs Road
Atmore, AL 36502
Escambia County
T2N, R5E, Section 26 and 35

PERMIT NUMBER: AL0059498

DSN & RECEIVING STREAM: 001 - 1 Unnamed Tributary to Sizemore Creek

In accordance with and subject to the provisions of the Federal Water Pollution Control Act, as amended, 33 U.S.C. §§1251-1388 (the "FWPCA"), the Alabama Water Pollution Control Act, as amended, Code of Alabama 1975, §§ 22-22-1 to 22-22-14 (the "AWPCA"), the Alabama Environmental Management Act, as amended, Code of Alabama 1975, §§22-22A-1 to 22-22A-17, and rules and regulations adopted thereunder, and subject further to the terms and conditions set forth in this permit, the Permittee is hereby authorized to discharge into the above-named receiving waters.

ISSUANCE DATE:

EFFECTIVE DATE:

EXPIRATION DATE:

Draft

Alabama Department of Environmental Management

**MINING AND NATURAL RESOURCE SECTION
NATIONAL POLLUTANT DISCHARGE ELIMINATION SYSTEM (NPDES) PERMIT**

TABLE OF CONTENTS

PART I	DISCHARGE LIMITATIONS, CONDITIONS, AND REQUIREMENTS	
A.	DISCHARGE LIMITATIONS AND MONITORING REQUIREMENTS.....	4
B.	REQUIREMENTS TO ACTIVATE A PROPOSED MINING OUTFALL.....	4
C.	DISCHARGE MONITORING AND RECORD KEEPING REQUIREMENTS	4
	1. Sampling Schedule and Frequency.....	4
	2. Measurement Frequency	5
	3. Monitoring Schedule	5
	4. Sampling Location.....	6
	5. Representative Sampling	6
	6. Test Procedures	6
	7. Recording of Results	7
	8. Routine Inspection by Permittee.....	7
	9. Records Retention and Production.....	8
	10. Monitoring Equipment and Instrumentation	8
D.	DISCHARGE REPORTING REQUIREMENTS.....	8
	1. Requirements for Reporting of Monitoring.....	8
	2. Noncompliance Notification	10
	3. Reduction, Suspension, or Termination of Monitoring and/or Reporting.....	11
E.	OTHER REPORTING AND NOTIFICATION REQUIREMENTS.....	12
	1. Anticipated Noncompliance.....	12
	2. Termination of Discharge.....	12
	3. Updating Information	12
	4. Duty to Provide Information.....	13
F.	SCHEDULE OF COMPLIANCE.....	13
PART II	OTHER REQUIREMENTS, RESPONSIBILITIES, AND DUTIES	
A.	OPERATIONAL AND MANAGEMENT REQUIREMENTS.....	14
	1. Facilities Operation and Management	14
	2. Pollution Abatement and/or Prevention Plan	14
	3. Best Management Practices (BMPs).....	14
	4. Biocide Additives.....	16
	5. Facility Identification.....	16
	6. Removed Substances.....	16
	7. Loss or Failure of Treatment Facilities	16
	8. Duty to Mitigate.....	17
B.	BYPASS AND UPSET	17
	1. Bypass.....	17
	2. Upset.....	18
C.	PERMIT CONDITIONS AND RESTRICTIONS.....	19
	1. Prohibition against Discharge from Facilities Not Certified	19
	2. Permit Modification, Suspension, Termination, and Revocation	19
	3. Automatic Expiration of Permits for New or Increased Discharges.....	20
	4. Transfer of Permit.....	21
	5. Groundwater	21
	6. Property and Other Rights.....	21

D.	RESPONSIBILITIES	21
1.	Duty to Comply	21
2.	Change in Discharge	22
3.	Compliance with Toxic or Other Pollutant Effluent Standard or Prohibition	22
4.	Compliance with Water Quality Standards and Other Provisions.....	23
5.	Compliance with Statutes and Rules	23
6.	Right of Entry and Inspection	23
7.	Duty to Reapply or Notify of Intent to Cease Discharge.....	24
PART III	ADDITIONAL REQUIREMENTS, CONDITIONS, AND LIMITATIONS	
A.	CIVIL AND CRIMINAL LIABILITY.....	25
1.	Tampering.....	25
2.	False Statements	25
3.	Permit Enforcement.....	25
4.	Relief From Liability.....	25
B.	OIL AND HAZARDOUS SUBSTANCE LIABILITY	25
C.	AVAILABILITY OF REPORTS.....	25
D.	DEFINITIONS	25
E.	SEVERABILITY.....	30
F.	PROHIBITIONS AND ACTIVITIES NOT AUTHORIZED.....	30
G.	DISCHARGES TO IMPAIRED WATERS.....	30
H.	COASTAL ZONE MANAGEMENT	31

PART I DISCHARGE LIMITATIONS, CONDITIONS, AND REQUIREMENTS

A. DISCHARGE LIMITATIONS AND MONITORING REQUIREMENTS

During the period beginning on the effective date of this Permit and lasting through the expiration date of this Permit, the Permittee is authorized to discharge from each point source identified on Page 1 of this Permit and described more fully in the Permittee's application, if the outfalls have been constructed and certified. Discharges shall be limited and monitored by the Permittee as specified below:

Parameter	Discharge Limitations			Monitoring Requirements	
	Daily Minimum	Monthly Average	Daily Maximum	Sample Type	Measurement Frequency ¹
pH 00400	6.0 s.u.	-----	8.5 s.u.	Grab	2/Month
Solids, Total Suspended 00530	-----	35.0 mg/L	70.0 mg/L	Grab	2/Month
Flow, In Conduit or Thru Treatment Plant ² 50050	-----	Report MGD	Report MGD	Instantaneous	2/Month

B. REQUIREMENTS TO ACTIVATE A PROPOSED MINING OUTFALL

1. Discharge from any point source identified on Page 1 of this Permit which is a proposed outfall is not authorized by this Permit until the outfall has been constructed and certification received by the Department from a professional engineer, registered in the State of Alabama, certifying that such facility has been constructed according to good engineering practices and in accordance with the Pollution Abatement and/or Prevention (PAP) Plan.
2. Certification required by Part I.B.1. shall be submitted on a completed ADEM Form 432. The certification shall include the latitude and longitude of the constructed and certified outfall.
3. Discharge monitoring and Discharge Monitoring Report (DMR) reporting requirements described in Part I.C. of this Permit do not apply to point sources that have not been constructed and certified.
4. Upon submittal of the certification required by Part I.B.1. to the Department, all monitoring and DMR submittal requirements shall apply to the constructed and certified outfall.

C. DISCHARGE MONITORING AND RECORD KEEPING REQUIREMENTS

1. Sampling Schedule and Frequency

- a. The Permittee shall collect at least one grab sample of the discharge to surface waters from each constructed and certified point source identified on Page 1 of this Permit and described more fully in the Permittee's application twice per month at a rate of at least every other week if a discharge occurs at any time during the two week period, but need not collect more than two samples per calendar month. Each sample collected shall be analyzed for each parameter specified in Part I.A. of this Permit.

¹ See Part I.C.2. for further measurement frequency requirements.

² Flow must be determined at the time of sample collection by direct measurement, calculation, or other method acceptable to the Department.

- b. If the final effluent is pumped in order to discharge (e.g. from incised ponds, old highwall cuts, old pit areas or depressions, etc.), the Permittee shall collect at least one grab sample of the discharge from each point source identified on Page 1 of this Permit and described more fully in the Permittee's application each quarterly (three month) monitoring period if a discharge occurs at any time during the quarterly monitoring period which results from direct pumped drainage. Each sample collected shall be analyzed for each parameter specified in Part I.A. of this Permit.
- c. The Permittee may increase the frequency of sampling listed in Parts I.C.1.a and I.C.1.b; however, all sampling results must be reported to the Department and included in any calculated results submitted to the Department in accordance with this Permit.

2. Measurement Frequency

Measurement frequency requirements found in Part I.A. shall mean:

- a. A measurement frequency of one day per week shall mean sample collection on any day of discharge which occurs every calendar week.
- b. A measurement frequency of two days per month shall mean sample collection on any day of discharge which occurs every other week, but need not exceed two sample days per month.
- c. A measurement frequency of one day per month shall mean sample collection on any day of discharge which occurs during each calendar month.
- d. A measurement frequency of one day per quarter shall mean sample collection on any day of discharge which occurs during each calendar quarter.
- e. A measurement frequency of one day per six months shall mean sample collection on any day of discharge which occurs during the period of January through June and during the period of July through December.
- f. A measurement frequency of one day per year shall mean sample collection on any day of discharge which occurs during each calendar year.

3. Monitoring Schedule

The Permittee shall conduct the monitoring required by Part I.A. in accordance with the following schedule:

- a. MONITORING REQUIRED MORE FREQUENTLY THAN MONTHLY AND MONTHLY shall be conducted during the first full month following the effective date of coverage under this Permit and every month thereafter. More frequently than monthly and monthly monitoring may be done anytime during the month, unless restricted elsewhere in this Permit, but the results should be reported on the last Discharge Monitoring Report (DMR) due for the quarter (i.e., with the March, June, September, and December DMRs).
- b. QUARTERLY MONITORING shall be conducted at least once during each calendar quarter. Calendar quarters are the periods of January through March, April through June, July through September, and October through December. The Permittee shall conduct the quarterly monitoring during the first complete calendar quarter following the effective date of this Permit and is then required to monitor once during each quarter thereafter. Quarterly monitoring may be done anytime during the quarter, unless restricted elsewhere in this

Permit, but the results should be reported on the last DMR due for the quarter (i.e., with the March, June, September, and December DMRs).

- c. SEMIANNUAL MONITORING shall be conducted at least once during the period of January through June and at least once during the period of July through December. The Permittee shall conduct the semiannual monitoring during the first complete semiannual calendar period following the effective date of this Permit and is then required to monitor once during each semiannual period thereafter. Semiannual monitoring may be done anytime during the semiannual period, unless restricted elsewhere in this Permit, but it should be reported on the last DMR due for the month of the semiannual period (i.e., with the June and December DMRs).
- d. ANNUAL MONITORING shall be conducted at least once during the period of January through December. The Permittee shall conduct the annual monitoring during the first complete calendar annual period following the effective date of this Permit and is then required to monitor once during each annual period thereafter. Annual monitoring may be done anytime during the year, unless restricted elsewhere in this Permit, but it should be reported on the December DMR.

4. Sampling Location

Unless restricted elsewhere in this Permit, samples collected to comply with the monitoring requirements specified in Part I.A. shall be collected at the nearest accessible location just prior to discharge and after final treatment, or at an alternate location approved in writing by the Department.

5. Representative Sampling

Sample collection and measurement actions taken as required herein shall be representative of the volume and nature of the monitored discharge and shall be in accordance with the provisions of this Permit.

6. Test Procedures

For the purpose of reporting and compliance, Permittees shall use one of the following procedures:

- a. For parameters with an EPA established Minimum Level (ML), report the measured value if the analytical result is at or above the ML and report "0" for values below the ML. Test procedures for the analysis of pollutants shall conform to 40 CFR Part 136, guidelines published pursuant to Section 304(h) of the FWPCA, 33 U.S.C. Section 1314(h), and ADEM Standard Operating Procedures. If more than one method for analysis of a substance is approved for use, a method having a minimum level lower than the permit limit shall be used. If the minimum level of all methods is higher than the permit limit, the method having the lowest minimum level shall be used and a report of less than the minimum level shall be reported as zero and will constitute compliance, however should EPA approve a method with a lower minimum level during the term of this Permit the Permittee shall use the newly approved method.
- b. For pollutant parameters without an established ML, an interim ML may be utilized. The interim ML shall be calculated as 3.18 times the Method Detection Level (MDL) calculated pursuant to 40 CFR Part 136, Appendix B.

Permittees may develop an effluent matrix-specific ML, where an effluent matrix prevents attainment of the established ML. However, a matrix specific ML shall be based upon proper laboratory method and technique. Matrix-specific MLs must be approved by the

Department, and may be developed by the Permittee during permit issuance, reissuance, modification, or during compliance schedule.

In either case the measured value should be reported if the analytical result is at or above the ML and "0" reported for values below the ML.

- c. For parameters without an EPA established ML, interim ML, or matrix-specific ML, a report of less than the detection limit shall constitute compliance if the detection limit of all analytical methods is higher than the permit limit using the most sensitive EPA approved method. For the purpose of calculating a monthly average, "0" shall be used for values reported less than the detection limit.

The Minimum Level utilized for procedures identified in Parts I.C.6.a. and b. shall be reported on the Permittee's DMR. When an EPA approved test procedure for analysis of a pollutant does not exist, the Director shall approve the procedure to be used.

7. Recording of Results

For each measurement or sample taken pursuant to the requirements of this Permit, the Permittee shall record the following information:

- a. The facility name and location, point source number, date, time, and exact place of sampling or measurements;
- b. The name(s) of person(s) who obtained the samples or measurements;
- c. The dates and times the analyses were performed;
- d. The name(s) of the person(s) who performed the analyses;
- e. The analytical techniques or methods used including source of method and method number; and
- f. The results of all required analyses.

8. Routine Inspection by Permittee

- a. The Permittee shall inspect all point sources identified on Page 1 of this Permit and described more fully in the Permittee's application and all treatment or control facilities or systems used by the Permittee to achieve compliance with the terms and conditions of this Permit at least as often as the applicable sampling frequency specified in Part I.C.1 of this Permit.
- b. The Permittee shall maintain a written log for each point source identified on Page 1 of this Permit and described more fully in the Permittee's application in which the Permittee shall record the following information:
 - (1) The date and time the point source and any associated treatment or control facilities or systems were inspected by the Permittee;
 - (2) Whether there was a discharge from the point source at the time of inspection by the Permittee;
 - (3) Whether a sample of the discharge from the point source was collected at the time of inspection by the Permittee;

- (4) Whether all associated treatment or control facilities or systems appeared to be in good working order and operating as efficiently as possible, and if not, a description of the problems or deficiencies; and
- (5) The name and signature of the person performing the inspection of the point source and associated treatment or control facilities or systems.

9. Records Retention and Production

- a. The Permittee shall retain records of all monitoring information, including all calibration and maintenance records and all original strip chart recordings for continuous monitoring instrumentation, copies of all reports required by this Permit, and records of all data used to complete the above reports or the application for this Permit, for a period of at least three (3) years from the date of the sample collection, measurement, report, or application. This period may be extended by request of the Director at any time. If litigation or other enforcement action, under the AWPCA, AEMA, and/or the FWPCA, is ongoing which involves any of the above records, the records shall be kept until the litigation is resolved. Upon the written request of the Director, the Permittee shall provide the Director with a copy of any record required to be retained by this paragraph. Copies of these records should not be submitted unless requested.
- b. All records required to be kept for a period of three (3) years shall be kept at the permitted facility or an alternate location approved by the Department in writing and shall be available for inspection.

10. Monitoring Equipment and Instrumentation

All equipment and instrumentation used to determine compliance with the requirements of this Permit shall be installed, maintained, and calibrated in accordance with the manufacturer's instructions or, in the absence of manufacturer's instructions, in accordance with accepted practices. The Permittee shall develop and maintain quality assurance procedures to ensure proper operation and maintenance of all equipment and instrumentation. The quality assurance procedures shall include the proper use, maintenance, and installation, when appropriate, of monitoring equipment at the plant site.

D. DISCHARGE REPORTING REQUIREMENTS

1. Requirements for Reporting of Monitoring

- a. Monitoring results obtained during the previous three (3) months shall be summarized for each month on a Discharge Monitoring Report (DMR) Form approved by the Department, and submitted to the Department so that it is received by the Director no later than the 28th day of the month following the quarterly reporting period (i.e., on the 28th day of January, April, July, and October of each year).
- b. The Department utilizes a web-based electronic reporting system for submittal of DMRs. **Except as allowed by Part I.D.1.c. or d., the Permittee shall submit all DMRs required by Part I.D.1.a. by utilizing the Department's current electronic reporting system.** The Department's current reporting system, Alabama Environmental Permitting and Compliance System (AEPACS), can be found online at <https://aepacs.adem.alabama.gov/nviro/ncore/external/home>.

- c. If the electronic reporting system is down (i.e. electronic submittal of DMR data is unable to be completed due to technical problems originating with the Department's system; this could include entry/submittal issues with an entire set of DMRs or individual parameters), permittees are not relieved of their obligation to submit DMR data to the Department by the required submittal date. However, if the electronic reporting system is down on the 28th day of the month or is down for an extended period of time as determined by the Department when a DMR is required to be submitted, the facility may submit the data in an alternate manner and format acceptable to the Department. Preapproved alternate acceptable methods include faxing, e-mailing, mailing, or hand-delivery of data such that they are received by the required reporting date. Within five calendar days of the electronic reporting system resuming operation, the Permittee shall enter the data into the reporting system unless an alternate timeframe is approved by the Department. An attachment should be included with the electronic DMR submittal verifying the original submittal date (date of the fax, copy of dated e-mail, or hand-delivery stamped date).
- d. The permittee may submit a request to the Department for a temporary electronic reporting waiver for DMR submittals. The waiver request should include the permit number; permittee name; facility/site name; facility address; name, address, and contact information for the responsible official or duly authorized representative; a detailed statement regarding the basis for requesting such a waiver; and the duration for which the waiver is requested. Approved electronic reporting waivers are not transferrable. Permittees with an approved electronic reporting waiver for DMRs may submit hard copy DMRs for the period that the approved electronic reporting waiver request is effective. The Permittee shall submit the Department-approved DMR forms to the address listed in Part I.D.1.i.
- e. If the Permittee, using approved analytical methods as specified in Part I.C.6., monitors any discharge from a point source identified on Page 1 of this Permit and describe more fully in the Permittee's application more frequently than required by this Permit; the results of such monitoring shall be included in the calculation and reporting of values on the DMR Form, and the increased frequency shall be indicated on the DMR Form.
- f. In the event no discharge from a point source identified on Page 1 of this Permit and described more fully in the Permittee's application occurs during a monitoring period, the Permittee shall report "No Discharge" for such period on the appropriate DMR Form.
- g. Each DMR Form submitted by the Permittee to the Department in accordance with Part I.D.1. must be legible and bear an original signature or electronic signature. Photo and electronic copies of the signature are not acceptable and shall not satisfy the reporting requirements of this Permit.
- h. All reports and forms required to be submitted by this Permit, the AWPCA, and the Department's rules and regulations, shall be signed by a "responsible official" of the Permittee as defined in ADEM Admin. Code r. 335-6-6-.09 or a "duly authorized representative" of such official as defined in ADEM Admin. Code r. 335-6-6-.09 and shall bear the following certification:

"I certify under penalty of law that this document and all attachments were prepared under my direction or supervision in accordance with a system designed to assure that qualified personnel properly gather and evaluate the information submitted. Based on my inquiry of the person or persons who manage the system, or those persons directly responsible for gathering the information, the information submitted is, to the best of my knowledge and belief, true, accurate, and complete. I am aware that there are significant penalties for submitting false information, including the possibility of fine and imprisonment for knowing violations."

- i. All DMRs, reports, and forms required to be submitted by this Permit, the AWPCA and the Department's rules and regulations, shall be submitted through the Department's electronic reporting system, AEPACS, or, if in hardcopy, shall be addressed to:

Alabama Department of Environmental Management
Water Division, Mining and Natural Resource Section
Post Office Box 301463
Montgomery, Alabama 36130-1463

Certified and Registered Mail shall be addressed to:

Alabama Department of Environmental Management
Water Division, Mining and Natural Resource Section
1400 Coliseum Boulevard
Montgomery, Alabama 36110-2059

- j. Unless authorized in writing by the Department, approved reporting forms required by this Permit or the Department are not to be altered, and if copied or reproduced, must be consistent in format and identical in content to the ADEM approved form. Unauthorized alteration, falsification, or use of incorrectly reproduced forms constitutes noncompliance with the requirements of this Permit and may significantly delay processing of any request, result in denial of the request, result in permit termination, revocation, suspension, modification, or denial of a permit renewal application, or result in other enforcement action.
- k. If this Permit is a reissuance, then the Permittee shall continue to submit DMRs in accordance with the requirements of their previous permit until such time as DMRs are due as discussed in Part I.D.1.

2. Noncompliance Notification

- a. The Permittee must notify the Department if, for any reason, the Permittee's discharge:
- (1) Potentially threatens human health or welfare;
 - (2) Potentially threatens fish or aquatic life;
 - (3) Causes an in-stream water quality criterion to be exceeded;
 - (4) Does not comply with an applicable toxic pollutant effluent standard or prohibition established under Section 307(a) of the FWPCA, 33 U.S.C. §1317(a);
 - (5) Contains a quantity of a hazardous substance which has been determined may be harmful to the public health or welfare under Section 311(b)(4) of the FWPCA, 33 U.S.C. §1321(b)(4); or
 - (6) Exceeds any discharge limitation for an effluent parameter as a result of an unanticipated bypass or upset.

The Permittee shall orally or electronically report any of the above occurrences, describing the circumstances and potential effects of such discharge to the Director within 24-hours after the Permittee becomes aware of the occurrence of such discharge. In addition to the oral or electronic report, the Permittee shall submit to the Director a written report as

provided in Part I.D.2.c., no later than five (5) days after becoming aware of the occurrence of such discharge.

- b. If for any reason, the Permittee's discharge does not comply with any limitation of this Permit, the Permittee shall submit a written report to the Director as provided in Part I.D.2.c. This report must be submitted with the next Discharge Monitoring Report required to be submitted by Part I.D.1. of this Permit after becoming aware of the occurrence of such noncompliance.
- c. Any written report required to be submitted to the Director in accordance with Parts I.D.2.a. and b. shall be submitted using a Noncompliance Notification Form (ADEM Form 421) available on the Department's website (<http://adem.alabama.gov/DeptForms/Form421.pdf>) and include the following information:
 - (1) A description of the discharge and cause of noncompliance;
 - (2) The period of noncompliance, including exact dates and times, or if not corrected, the anticipated time the noncompliance is expected to continue; and
 - (3) A description of the steps taken and/or being taken to reduce or eliminate the noncomplying discharge and to prevent its recurrence.

3. Reduction, Suspension, or Termination of Monitoring and/or Reporting

- a. The Director may, with respect to any point source identified on Page 1 of this Permit and described more fully in the Permittee's application, authorize the Permittee to reduce, suspend, or terminate the monitoring and/or reporting required by this Permit upon the submission of a written request for such reduction, suspension, or termination by the Permittee provided:
 - (1) All mining, processing, or disturbance in the drainage basin(s) associated with the discharge has ceased and site access is adequately restricted or controlled to preclude unpermitted and unauthorized mining, processing, transportation, or associated operations/activity;
 - (2) Permanent, perennial vegetation has been re-established on all areas mined or disturbed for at least one year since mining has ceased in the drainage basin(s) associated with the surface discharge, or all areas have been permanently graded such that all drainage is directed back into the mined pit to preclude all surface discharges;
 - (3) Unless waived in writing by the Department, the Permittee has been granted, in writing, a 100% Bond Release, if applicable, by the Alabama Department of Industrial Relations and, if applicable, by the Surface Mining Commission for all areas mined or disturbed in the drainage basin(s) associated with the discharge;
 - (4) Unless waived in writing by the Department, the Permittee has submitted inspection reports prepared and certified by a Professional Engineer (PE) registered in the State of Alabama or a qualified professional under the PE's direction which certify that the facility has been fully reclaimed or that water quality remediation has been achieved. The first inspection must be conducted approximately one year prior to and the second inspection must be conducted within thirty days of the Permittee's request for termination of monitoring and reporting requirements;

- (5) All surface effects of the mining activity such as fuel or chemical tanks, preparation plants or equipment, old tools or equipment, junk or debris, etc., must be removed and disposed of according to applicable state and federal regulations;
- (6) The Permittee's request for termination of monitoring and reporting requirements contained in this Permit has been supported by monitoring data covering a period of at least six consecutive months or such longer period as is necessary to assure that the data reflect discharges occurring during varying seasonal climatological conditions;
- (7) The Permittee has stated in its request that the samples collected and reported in the monitoring data submitted in support of the Permittee's request for monitoring termination or suspension are representative of the discharge and were collected in accordance with all Permit terms and conditions respecting sampling times (e.g., rainfall events) and methods and were analyzed in accordance with all Permit terms and conditions respecting analytical methods and procedures;
- (8) The Permittee has certified that during the entire period covered by the monitoring data submitted, no chemical treatment of the discharge was provided;
- (9) The Permittee's request has included the certification required by Part I.D.1.e. of this Permit; and
- (10) The Permittee has certified to the Director in writing as part of the request, its compliance with (1) through (9) above.

- b. It remains the responsibility of the Permittee to comply with the monitoring and reporting requirements of this Permit until written authorization to reduce, suspend, or terminate such monitoring and/or reporting is received by the Permittee from the Director.

E. OTHER REPORTING AND NOTIFICATION REQUIREMENTS

1. Anticipated Noncompliance

The Permittee shall give the Director written advance notice of any planned changes or other circumstances regarding a facility which may result in noncompliance with permit requirements.

2. Termination of Discharge

The Permittee shall notify the Director, in writing, when all discharges from any point source(s) identified on Page 1 of this Permit and described more fully in the Permittee's application have permanently ceased.

3. Updating Information

- a. The Permittee shall inform the Director of any change in the Permittee's mailing address or telephone number or in the Permittee's designation of a facility contact or officer(s) having the authority and responsibility to prevent and abate violations of the AWPCA, the AEMA, the Department's rules and regulations, and the terms and conditions of this Permit, in writing, no later than ten (10) days after such change. Upon request of the Director, the

Permittee shall furnish the Director with an update of any information provided in the permit application.

- b. If the Permittee becomes aware that it failed to submit any relevant facts in a permit application, or submitted incorrect information in a permit application or in any report to the Director, it shall promptly submit such facts or information with a written explanation for the mistake and/or omission.

4. Duty to Provide Information

- a. The Permittee shall furnish to the Director, within a reasonable time, any information which the Director may request to determine whether cause exists for modifying, suspending, terminating, or revoking and reissuing this Permit, in whole or in part, or to determine compliance with this Permit. The Permittee shall also furnish to the Director upon request, copies of records required to be maintained by this Permit.
- b. The Permittee shall furnish to the Director upon request, within a reasonable time, available information (name, phone number, address, and site location) which identifies offsite sources of material or natural resources (mineral, ore, or other material such as iron, coal, coke, dirt, chert, shale, clay, sand, gravel, bauxite, rock, stone, etc.) used in its operation or stored at the facility.

F. SCHEDULE OF COMPLIANCE

The Permittee shall achieve compliance with the discharge limitations specified in Part I.A. of this Permit in accordance with the following schedule:

Compliance must be achieved by the effective date of this Permit.

PART II OTHER REQUIREMENTS, RESPONSIBILITIES, AND DUTIES

A. OPERATIONAL AND MANAGEMENT REQUIREMENTS

1. Facilities Operation and Management

The Permittee shall at all times operate and maintain all facilities and systems of treatment and control (and related appurtenances) which are installed or used by the Permittee to achieve compliance with the conditions of this Permit. Proper operation and maintenance includes effective performance, adequate funding, adequate operator staffing and training, and adequate laboratory and process controls, including appropriate quality assurance procedures. This provision requires the operation of backup or auxiliary facilities only when necessary to achieve compliance with the conditions of this Permit.

2. Pollution Abatement and/or Prevention Plan

a. The Pollution Abatement and/or Prevention (PAP) Plan shall be prepared and certified by a registered Professional Engineer (PE), licensed to practice in the State of Alabama, and shall include at a minimum:

- (1) The information indicated in ADEM Admin Code r. 335-6-9-.03 and ADEM Admin. Code ch. 335-6-9 and its Appendices A and B;
- (2) A description of methods which will be implemented to prevent offsite vehicle tracking onto roadways and/or into ditches at the entrances and/or exits of the Permittee's operations;
- (3) A description of setbacks from waters of the State in units of linear feet on the horizontal plane; a description of the methods taken to visibly delineate setbacks from waters of the State; and a description of any other actions taken to prevent encroachment upon setbacks;
- (4) A description of the methods used to delineate the boundaries of coverage under this Permit such that the boundaries are readily visible during the life of the operation;
- (5) A description of any other Best Management Practices (BMPs) which will be implemented to provide control of all nonpoint source pollution that is or may be associated with the Permittee's operations;

b. The PAP Plan shall become a part of this Permit and all requirements of the PAP Plan shall become requirements of this Permit pursuant to ADEM Admin Code r. 335-6-9-.05(2). The PAP Plan shall be amended if the Department determines that the existing sediment control measures, erosion control measures, or other site management practices are ineffective or do not meet the requirements of this Permit.

c. For existing sources, the PAP Plan shall be updated to include all requirements of this section within 180 days of the effective date of this permit. New sources shall submit the PAP plan with the NPDES Individual Permit application prior to coverage under this Permit.

3. Best Management Practices (BMPs)

- a. Unless otherwise authorized in writing by the Director, the Permittee shall provide a means of subsurface withdrawal for any discharge from each point source identified on Page I of this Permit and described more fully in the Permittee's application. Notwithstanding the above provision, a means of subsurface withdrawal need not be provided for any discharge caused by a 24-hour precipitation event greater than a 10-year, 24-hour precipitation event.
- b. Dilution water shall not be added to achieve compliance with discharge limitations except when the Director has granted prior written authorization for dilution to meet water quality requirements.
- c. The Permittee shall minimize the contact of water with overburden, including but not limited to stabilizing disturbed areas through grading, diverting runoff, achieving quick growing stands of temporary vegetation, sealing acid-forming and toxic-forming materials, and maximizing placement of waste materials in back-fill areas.
- d. The Permittee shall prepare, submit to the Department for approval, and implement a Best Management Practices (BMPs) Plan for containment of any or all process liquids or solids, in a manner such that these materials do not present a potential for discharge, if so required by the Director. When submitted and approved, the BMP Plan shall become a part of this Permit and all requirements of the BMP Plan shall become requirements of this Permit.
- e. Spill Prevention, Control, and Management

The Permittee shall prepare, implement, and maintain a Spill Prevention, Control and Countermeasures (SPCC) Plan acceptable to the Department that is prepared and certified by a Professional Engineer (PE), registered in the State of Alabama, for all onsite petroleum product or other pollutant storage tanks or containers as provided by ADEM Admin. Code r. 335-6-6-.08(j)5. The Plan shall describe and the Permittee shall implement appropriate structural and/or non-structural spill prevention, control, and/or management pursuant to ADEM Admin. Code r. 335-6-6-.12 (r) sufficient to prevent any spills of pollutants from entering a ground or surface water of the State or a publicly or privately owned treatment works. The Plan shall include at a minimum, the engineering requirements provided in 40 C.F.R. §§112.1. Any containment system used to implement this requirement shall be constructed of materials compatible with the substance(s) contained and shall prevent the contamination of groundwater. Such containment systems shall be capable of retaining a volume equal to 110 percent of the capacity of the largest tank for which containment is provided. The Plan shall list any materials which the Permittee may utilize to contain and to absorb fuel and chemical spills and leaks. The Permittee shall maintain sufficient amounts of such materials onsite or have sufficient amounts of such materials readily available to contain and/or absorb fuel and chemical spills and leaks. Soil contaminated by chemical spills, oil spills, etc., must be immediately cleaned up or be removed and disposed of in a manner consistent with all State and federal regulations.

- f. All surface drainage and storm water runoff which originate within or enters the Permittee's premises and which contains any pollutants or other wastes shall be discharged, if at all, from a point source identified on Page I of this Permit and described more fully in the Permittee's application.
- g. The Permittee shall take all reasonable precautions to prevent any surface drainage or storm water runoff which originates outside the Permittee's premises and which contains any pollutants or other wastes from entering the Permittee's premises. At no time shall the Permittee discharge any such surface drainage or storm water runoff which enters the Permittee's premises if, either alone or in combination with the Permittee's effluent, the discharge would exceed any applicable discharge limitation specified in Part I.A. of this Permit.

4. Biocide Additives

- a. The Permittee shall notify the Director in writing not later than sixty (60) days prior to instituting the use of any biocide corrosion inhibitor or chemical additive in any cooling or boiler system(s) regulated by this Permit. Notification is not required for additives that should not reasonably be expected to cause the cooling water or boiler water to exhibit toxicity as determined by analysis of manufacturer's data or testing by the Permittee. Such notification shall include:
- (a) Name and general composition of biocide or chemical;
 - (b) 96-hour median tolerance limit data for organisms representative of the biota of the water(s) which the discharge(s) enter(s);
 - (c) Quantities to be used;
 - (d) Frequencies of use;
 - (e) Proposed discharge concentrations; and
 - (f) EPA registration number, if applicable.
- b. The use of any biocide or chemical additive containing tributyl tin, tributyl tin oxide, zinc, chromium, or related compounds in any cooling or boiler system(s) regulated by the Permit is prohibited except as exempted below. The use of a biocide or additive containing zinc, chromium or related compounds may be used in special circumstances if (1) the permit contains limits for these substances, or (2) the applicant demonstrates during the application process that the use of zinc, chromium or related compounds as a biocide or additive will not pose a reasonable potential to violate the applicable State water quality standards for these substances. The use of any additive, not identified in this Permit or in the application for this Permit or not exempted from notification under this Permit is prohibited, prior to a determination by the Department that permit modification to control discharge of the additive is not required or prior to issuance of a permit modification controlling discharge of the additive.

5. Facility Identification

The Permittee shall clearly display prior to commencement of any regulated activity and until permit coverage is properly terminated, the name of the Permittee, entire NPDES permit number, facility or site name, and other descriptive information deemed appropriate by the Permittee at an easily accessible location(s) to adequately identify the site, unless approved otherwise in writing by the Department. The Permittee shall repair or replace the sign(s) as necessary upon becoming aware that the identification is missing or is unreadable due to age, vandalism, theft, weather, or other reason.

6. Removed Substances

Solids, sludges, filter backwash, or any other pollutants or other wastes removed in the course of treatment or control of wastewaters shall be disposed of in a manner that complies with all applicable Department rules and regulations.

7. Loss or Failure of Treatment Facilities

Upon the loss or failure of any treatment facility, including but not limited to the loss or failure of the primary source of power of the treatment facility, the Permittee shall, where necessary to maintain compliance with the discharge limitations specified in Part I.A. of this Permit or any other terms or conditions of this Permit, cease, reduce, or otherwise control production and/or discharges until treatment is restored.

8. Duty to Mitigate

The Permittee shall promptly take all reasonable steps to minimize or prevent any violation of this Permit or to mitigate and minimize any adverse impact to waters resulting from noncompliance with any discharge limitation specified in Part I.A. of this Permit, including such accelerated or additional monitoring of the discharge and/or the receiving waterbody as is necessary to determine the nature and impact of the noncomplying discharge.

B. BYPASS AND UPSET

1. Bypass

- a. Any bypass is prohibited except as provided in Parts II.B.1.b. and c.
- b. A bypass is not prohibited if:
 - (1) It does not cause any applicable discharge limitation specified in Part I.A. of this Permit to be exceeded;
 - (2) The discharge resulting from such bypass enters the same receiving water as the discharge from the permitted outfall;
 - (3) It is necessary for essential maintenance of a treatment or control facility or system to assure efficient operation of such facility or system; and
 - (4) The Permittee monitors the discharge resulting from such bypass at a frequency, at least daily, sufficient to prove compliance with the discharge limitations specified in Part I.A. of this Permit.
- c. A bypass is not prohibited and need not meet the discharge limitations specified in Part I.A. of this Permit if:
 - (1) It is unavoidable to prevent loss of life, personal injury, or severe property damage;
 - (2) There are no feasible alternatives to the bypass, such as the use of auxiliary treatment facilities, retention of untreated wastes, or maintenance during normal periods of equipment downtime. This condition is not satisfied if the Permittee could have installed adequate backup equipment to prevent a bypass which occurred during normal periods of equipment downtime or preventive maintenance; and
 - (3) The Permittee submits a written request for authorization to bypass to the Director at least ten (10) days, if possible, prior to the anticipated bypass or within 24 hours of an unanticipated bypass, the Permittee is granted such authorization, and Permittee complies with any conditions imposed by the Director to minimize any adverse impact to waters resulting from the bypass.

- d. The Permittee has the burden of establishing that each of the conditions of Parts II.B.1.b. or c. have been met to qualify for an exception to the general prohibition against bypassing contained in Part II.B.1.a. and an exemption, where applicable, from the discharge limitations specified in Part I.A. of this Permit.

2. Upset

- a. The Permittee may seek to demonstrate that noncompliance with technology-based effluent limits occurred as a result of an upset if the conditions of Part II.B.2.b are met and if the Permittee complies with the conditions provided in Part II.B.2.c.
- b. If the Permittee wishes to establish the affirmative defense of an upset for technology-based effluent limit noncompliance, the Permittee must demonstrate through properly signed, contemporaneous operating logs, or other relevant evidence that:
 - (1) An upset occurred and that the Permittee can identify the specific cause(s) of the upset;
 - (2) The wastewater treatment facility was at the time being properly operated in accordance with Part II.B.d.
 - (3) The Permittee submitted notice of the noncompliance during the upset as required by Part II.B.2.c; and
 - (4) The Permittee complied with any remedial measures required under Part II.A.7. of this Permit.
- c. If the Permittee wishes to establish the affirmative defense of an upset for technology-based effluent limit noncompliance, the Permittee shall:
 - (1) No later than 24-hours after becoming aware of the occurrence of the upset, orally report the occurrence and circumstances of the upset to the Director in accordance with Part I.G.2.; and
 - (2) No later than five (5) days after becoming aware of the occurrence of the upset, furnish the Director with evidence, including properly signed, contemporaneous operating logs, design drawings, construction certification, maintenance records, weir flow measurements, dated photographs, rain gauge measurements, or other relevant evidence, demonstrating that:
 - (i) An upset occurred;
 - (ii) The Permittee can identify the specific cause(s) of the upset;
 - (iii) The Permittee's treatment facility was being properly operated at the time of the upset; and
 - (iv) The Permittee promptly took all reasonable steps to minimize any adverse impact to waters resulting from the upset.
- d. A discharge which is an overflow from a treatment facility or system, or an excess discharge from a point source associated with a treatment facility or system and which results from a 24-hour precipitation event larger than a 10-year, 24-hour precipitation event is not eligible to be considered as a result of an upset unless:

- (1) The treatment facility or system is designed, constructed, and maintained to contain the maximum volume of wastewater which would be generated by the facility during a 24-hour period without an increase in volume from precipitation and the maximum volume of wastewater resulting from a 10-year, 24-hour precipitation event or to treat the maximum flow associated with these volumes. In computing the maximum volume of wastewater which would result from a 10-year, 24-hour precipitation event, the volume which would result from all areas contributing runoff to the individual treatment facility must be included (i.e., all runoff that is not diverted from the mining area and runoff which is not diverted from the preparation plant area); and
 - (2) The Permittee takes all reasonable steps to maintain treatment of the wastewater and minimize the amount of overflow or excess discharge.
- e. The Permittee has the burden of proof in defense of any enforcement action as a result of noncompliance of technology-based effluent limits the Permittee proposes to attribute to an upset.

C. PERMIT CONDITIONS AND RESTRICTIONS

1. Prohibition against Discharge from Facilities Not Certified

- a. Notwithstanding any other provisions of this Permit, if the permitted facility has not obtained or is not required to obtain a permit from the Alabama Surface Mining Commission, any discharge(s) from any point or nonpoint source(s) from the permitted facility which was not certified to the Department on a form approved by the Department by a professional engineer, registered in the State of Alabama, as being designed, constructed, and in accordance with plans and specifications reviewed by the Department is prohibited; or
- b. Notwithstanding any other provisions of this Permit, if the permitted facility has obtained or is required to obtain a permit from the Alabama Surface Mining Commission, any discharge(s) from any point or nonpoint source(s) from the permitted facility which is associated with a treatment facility which was not constructed and certified to the Alabama Surface Mining Commission pursuant to applicable provisions of said Commission's regulations, is prohibited until the Permittee submits to the Alabama Surface Mining Commission, certification by a professional engineer, registered in the State of Alabama, certifying that such facility has been constructed in accordance with plans and specifications approved by the Alabama Surface Mining Commission. This requirement shall not apply to pumped discharges from the underground works of underground coal mines where no surface structure is required by the Alabama Surface Mining Commission, provided the Department is notified in writing of the completion or installation of such facilities, and the pumped discharges will meet permit effluent limits without treatment.

2. Permit Modification, Suspension, Termination, and Revocation

- a. This Permit may be modified, suspended, terminated, or revoked and reissued, in whole or in part, during its term for cause, including but not limited to, the following:
 - (1) The violation of any term or condition of this Permit;

- (2) The obtaining of this Permit by misrepresentation or the failure to disclose fully all relevant facts;
 - (3) The submission of materially false or inaccurate statements or information in the permit application or reports required by the Permit;
 - (4) The need for a change in any condition that requires either a temporary or permanent reduction or elimination of the permitted discharge;
 - (5) The existence of any typographical or clerical errors or of any errors in the calculation of discharge limitations;
 - (6) The existence of material and substantial alterations or additions to the facility or activity generating wastewater which occurred after permit issuance which justify the application of permit conditions that are different or absent in the existing permit;
 - (7) The threat of the Permittee's discharge on human health or welfare; or
 - (8) Any other cause allowed by ADEM Admin. Code ch. 335-6-6.
- b. The filing of a request by the Permittee for modification, suspension, termination, or revocation and reissuance of this Permit, in whole or in part, does not stay any Permit term or condition of this Permit.

3. Automatic Expiration of Permits for New or Increased Discharges

- a. Except as provided by ADEM Admin. Code r. 335-6-6-.02(h) and 335-6-6-.05, if this Permit was issued for a new discharger or new source, it shall expire eighteen months after the issuance date if construction has not begun during that eighteen month period.
- b. Except as provided by ADEM Admin. Code r. 335-6-6-.02(h) and 335-6-6-.05, if any portion of this Permit was issued or modified to authorize the discharge of increased quantities of pollutants to accommodate the modification of an existing facility, that portion of this Permit shall expire eighteen months after this Permit's issuance if construction of the modification has not begun within eighteen month period.
- c. Construction has begun when the owner or operator has:
 - (1) Begun, or caused to begin as part of a continuous on-site construction program:
 - (i) Any placement, assembly, or installation of facilities or equipment; or
 - (ii) Significant site preparation work including clearing, excavation, or removal of existing buildings, structures, or facilities which is necessary for the placement, assembly, or installation of new source facilities or equipment; or
 - (2) Entered into a binding contractual obligation for the purpose of placement, assembly, or installation of facilities or equipment which are intended to be used in its operation within a reasonable time. Options to purchase or contracts which can be terminated or modified without substantial loss, and contracts for feasibility, engineering, and design studies do not constitute a contractual obligation under the paragraph. The entering into a lease with the State of

Alabama for exploration and production of hydrocarbons shall also be considered beginning construction.

- d. The automatic expiration of this Permit for new or increased discharges if construction has not begun within the eighteen month period after the issuance of this Permit may be tolled by administrative or judicial stay.

4. Transfer of Permit

This Permit may not be transferred or the name of the Permittee changed without notice to the Director and subsequent modification or revocation and reissuance of this Permit to identify the new Permittee and to incorporate any other changes as may be required under the FWPCA or AWPCA. In the case of a change in name, ownership, or control of the Permittee's premises only, a request for permit modification in a format acceptable to the Director is required at least 30 days prior to the change. In the case of a change in name, ownership, or control of the Permittee's premises accompanied by a change or proposed change in effluent characteristics, a complete permit application is required to be submitted to the Director at least 180 days prior to the change. Whenever the Director is notified of a change in name, ownership, or control, he may decide not to modify the existing Permit and require the submission of a new permit application.

5. Groundwater

Unless authorized on page 1 of this Permit, this Permit does not authorize any discharge to groundwater. Should a threat of groundwater contamination occur, the Director may require groundwater monitoring to properly assess the degree of the problem, and the Director may require that the Permittee undertake measures to abate any such discharge and/or contamination.

6. Property and Other Rights

This Permit does not convey any property rights in either real or personal property, or any exclusive privileges, nor does it authorize any injury to persons or property or invasion of other private rights, trespass, or any infringement of Federal, State, or local laws or regulations, nor does it authorize or approve the construction of any physical structures or facilities or the undertaking of any work in any waters of the State or of the United States.

D. RESPONSIBILITIES

1. Duty to Comply

- a. The Permittee must comply with all terms and conditions of this Permit. Any permit noncompliance constitutes a violation of the AWPCA, AEMA, and the FWPCA and is grounds for enforcement action, for permit termination, revocation and reissuance, suspension, modification, or denial of a permit renewal application.
- b. The Permittee shall comply with effluent standards or prohibitions established under Section 307(a) of the FWPCA for toxic pollutants within the time provided in the regulations that establish these standards or prohibitions, even if this Permit has not yet been modified to incorporate the effluent standard, prohibition or requirement.
- c. For any violation(s) of this Permit, the Permittee is subject to a civil penalty as authorized by the AWPCA, the AEMA, the FWPCA, and Code of Alabama 1975, §§22-22A-1 et. seq., as amended, and/or a criminal penalty as authorized by Code of Alabama 1975, §22-22-1 et. seq., as amended.

- d. The necessity to halt or reduce production or other activities in order to maintain compliance with the conditions of this Permit shall not be a defense for a Permittee in an enforcement action.
- e. Nothing in this Permit shall be construed to preclude or negate the Permittee's responsibility or liability to apply for, obtain, or comply with other ADEM, federal, state, or local government permits, certifications, licenses, or other approvals.
- f. The discharge of a pollutant from a source not specifically identified in the permit application for this Permit and not specifically included in the description of an outfall in this Permit is not authorized and shall constitute noncompliance with this Permit.
- g. The Permittee shall take all reasonable steps, including cessation of production or other activities, to minimize or prevent any violation of this Permit or to minimize or prevent any adverse impact of any permit violation.

2. Change in Discharge

- a. The Permittee shall apply for a permit modification at least 180 days in advance of any facility expansion, production increase, process change, or other action that could result in the discharge of additional pollutants, increase the quantity of a discharged pollutant, or that could result in an additional discharge point. This requirement also applies to pollutants that are not subject to discharge limitations in this Permit. No new or increased discharge may begin until the Director has authorized it by issuance of a permit modification or a reissued permit.
- b. The Permittee shall notify the Director as soon as it knows or has reason to believe that it has begun or expects to begin to discharge any pollutant listed as a toxic pollutant pursuant to Section 307(a) of the FWPCA, 33 U.S.C. §1317(a), any substance designated as a hazardous substance pursuant to Section 311(b)(2) of the FWPCA, 33 U.S.C. §1321(b)(2), any waste listed as a hazardous waste pursuant to Code of Alabama 1975, §22-30-10, or any other pollutants or other wastes which is not subject to any discharge limitations specified in Part I.A. of this Permit and was not reported in the Permittee's application, was reported in the Permittee's application in concentrations or mass rates lower than that which the Permittee expects to begin to be discharged, or has reason to believe has begun to be discharged.

3. Compliance with Toxic or Other Pollutant Effluent Standard or Prohibition

If any applicable effluent standard or prohibition (including any schedule of compliance specified in such effluent standard or prohibition) is established under Sections 301(b)(2)(C),(D),(E) and (F) of the FWPCA, 33 U.S.C. §1311(b)(2)(C),(D),(E), and (F); 304(b)(2) of the FWPCA, 33 U.S.C. §1314(b)(2); or 307(a) of the FWPCA, 33 U.S.C. §1317(a), for a toxic or other pollutant discharged by the Permittee, and such standard or prohibition is more stringent than any discharge limitation on the pollutant specified in Part I.A. of this Permit or controls a pollutant not limited in Part I.A. of this Permit, this Permit shall be modified to conform to the toxic or other pollutant effluent standard or prohibition and the Permittee shall be notified of such modification. If this Permit has not been modified to conform to the toxic or other pollutant effluent standard or prohibition before the effective date of such standard or prohibition, the authorization to discharge in this Permit shall be void to the extent that any discharge limitation on such pollutant in Part I.A. of this Permit exceeds or is inconsistent with the established toxic or other pollutant effluent standard or prohibition.

4. Compliance with Water Quality Standards and Other Provisions

- a. On the basis of the Permittee's application, plans, or other available information, the Department has determined that compliance with the terms and conditions of this Permit will assure compliance with applicable water quality standards. However, this Permit does not relieve the Permittee from compliance with applicable State water quality standards established in ADEM Admin. Code ch. 335-6-10, and does not preclude the Department from taking action as appropriate to address the potential for contravention of applicable State water quality standards which could result from discharges of pollutants from the permitted facility.
- b. Compliance with Permit terms and conditions notwithstanding, if the Permittee's discharge(s) from point source(s) identified on Page 1 of this Permit cause(s) or contribute(s) to a condition in contravention of State water quality standards, the Department may require abatement action to be taken by the Permittee, modify the Permit pursuant to the Department's rules and regulations, or both.
- c. If the Department determines, on the basis of a notice provided pursuant to Part II.C.2. of this Permit or any investigation, inspection, or sampling, that a modification of this Permit is necessary to assure maintenance of water quality standards or compliance with other provisions of the AWPCA or FWPCA, the Department may require such modification and, in cases of emergency, the Director may prohibit the noticed act until the Permit has been modified.

5. Compliance with Statutes and Rules

- a. This Permit has been issued under ADEM Admin. Code div. 335-6. All provisions of this division, that are applicable to this Permit, are hereby made a part of this Permit. A copy of this division may be obtained for a small charge from the Office of General Counsel, Alabama Department of Environmental Management, 1400 Coliseum Blvd., Montgomery, AL 36110-2059.
- b. This Permit does not authorize the noncompliance with or violation of any Laws of the State of Alabama or the United States of America or any regulations or rules implementing such laws. FWPCA, 33 U.S.C. Section 1319, and Code of Alabama 1975, Section 22-22-14.

6. Right of Entry and Inspection

The Permittee shall allow the Director, or an authorized representative, upon the presentation of credentials and other documents as may be required by law to:

- a. Enter upon the Permittee's premises where a regulated facility or activity is located or conducted, or where records must be kept under the conditions of the Permit;
- b. Have access to and copy, at reasonable times, any records that must be kept under the conditions of this Permit;
- c. Inspect at reasonable times any facilities, equipment (including monitoring and control equipment), practices, or operations regulated or required under this Permit; and
- d. Sample or monitor at reasonable times, for the purposes of assuring Permit compliance or as otherwise authorized by the AWPCA, any substances or parameters at any location.

7. Duty to Reapply or Notify of Intent to Cease Discharge

- a. If the Permittee intends to continue to discharge beyond the expiration date of this Permit, the Permittee shall file with the Department a complete permit application for reissuance of this Permit at least 180 days prior to its expiration. **Applications must be submitted electronically via the Department's current electronic permitting system. The Department's current online permitting system, Alabama Environmental Permitting and Compliance System (AEPACS), can be found online at <https://aepacs.adem.alabama.gov/nviro/ncore/external/home>.**
- b. If the Permittee does not desire to continue the discharge(s) allowed by this Permit, the Permittee shall notify the Department at least 180 days prior to expiration of this Permit of the Permittee's intention not to request reissuance of this Permit. This notification must include the information required in Part I.D.4.a. and be signed by an individual meeting the signatory requirements for a permit application as set forth in ADEM Admin. Code r. 335-6-6-.09.
- c. Failure of the Permittee to submit to the Department a complete application for reissuance of this Permit at least 180 days prior to the expiration date of this Permit will void the automatic continuation of this Permit provided by ADEM Admin. Code r. 335-6-6-.06; and should this Permit not be reissued for any reason, any discharge after the expiration of this Permit will be an unpermitted discharge.

PART III ADDITIONAL REQUIREMENTS, CONDITIONS, AND LIMITATIONS

A. CIVIL AND CRIMINAL LIABILITY

1. Tampering

Any person who falsifies, tampers with, or knowingly renders inaccurate any monitoring device or method required to be maintained or performed under this Permit shall, upon conviction, be subject to penalties and/or imprisonment as provided by the AWPCA and/or the AEMA.

2. False Statements

Any person who knowingly makes any false statement, representation, or certification in any record or other document submitted or required to be maintained under this Permit, including monitoring reports or reports of compliance or noncompliance shall, upon conviction, be punished as provided by applicable State and Federal law.

3. Permit Enforcement

This NPDES Permit is a Permit for the purpose of the AWPCA, the AEMA, and the FWPCA, and as such all terms, conditions, or limitations of this Permit are enforceable under State and Federal law.

4. Relief From Liability

Except as provided in Part II.B.1. (Bypass) and Part II.B.2. (Upset), nothing in this Permit shall be construed to relieve the Permittee of civil or criminal liability under the AWPCA, AEMA, or FWPCA for noncompliance with any term or condition of this Permit.

B. OIL AND HAZARDOUS SUBSTANCE LIABILITY

Nothing in this Permit shall be construed to preclude the institution of any legal action or relieve the Permittee from any responsibilities, liabilities, or penalties to which the Permittee is or may be subject to under Section 311 of the FWPCA, 33 U.S.C. §1321.

C. AVAILABILITY OF REPORTS

Except for data determined to be confidential under Code of Alabama 1975, §22-22-9(c), all reports prepared in accordance with the terms of this Permit shall be available for public inspection at the offices of the Department. Effluent data shall not be considered confidential. Knowingly making any false statement in any such report may result in the imposition of criminal penalties as provided for in Section 309 of the FWPCA, 33 U.S.C. §1319, and Code of Alabama 1975, §22-22-14.

D. DEFINITIONS

1. Alabama Environmental Management Act (AEMA) - means Code of Alabama 1975, §§22-22A-1 et. seq., as amended.
2. Alabama Water Pollution Control Act (AWPCA) - means Code of Alabama 1975, §§22-22-1 et. seq., as amended.
3. Average monthly discharge limitation - means the highest allowable average of "daily discharges" over a calendar month, calculated as the sum of all "daily discharges" measured during a calendar

month divided by the number of "daily discharges" measured during that month (zero discharge days shall not be included in the number of "daily discharges" measured and a less than detectable test result shall be treated as a concentration of zero if the most sensitive EPA approved method was used).

4. Arithmetic Mean - means the summation of the individual values of any set of values divided by the number of individual values.
5. BOD - means the five-day measure of the pollutant parameter biochemical oxygen demand
6. Bypass - means the intentional diversion of waste streams from any portion of a treatment facility.
7. CBOD - means the five-day measure of the pollutant parameter carbonaceous biochemical oxygen demand.
8. Controlled Surface Mine Drainage – means any surface mine drainage that is pumped or siphoned from the active mining area.
9. Daily discharge - means the discharge of a pollutant measured during any consecutive 24-hour period in accordance with the sample type and analytical methodology specified by the discharge permit.
10. Daily maximum - means the highest value of any individual sample result obtained during a day.
11. Daily minimum - means the lowest value of any individual sample result obtained during a day.
12. Day - means any consecutive 24-hour period.
13. Department - means the Alabama Department of Environmental Management.
14. Director - means the Director of the Department or his authorized representative or designee.
15. Discharge - means "[t]he addition, introduction, leaking, spilling or emitting of any sewage, industrial waste, pollutant or other waste into waters of the state." Code of Alabama 1975, §22-22-1(b)(8).
16. Discharge monitoring report (DMR) - means the form approved by the Director to accomplish monitoring report requirements of an NPDES Permit.
17. DO - means dissolved oxygen.
18. E. coli – means the pollutant parameter Escherichia coli.
19. 8HC - means 8-hour composite sample, including any of the following:
 - a. The mixing of at least 5 equal volume samples collected at constant time intervals of not more than 2 hours over a period of not less than 8 hours between the hours of 6:00 a.m. and 6:00 p.m. If the sampling period exceeds 8 hours, sampling may be conducted beyond the 6:00 a.m. to 6:00 p.m. period.
 - b. A sample continuously collected at a constant rate over period of not less than 8 hours between the hours of 6:00 a.m. and 6:00 p.m. If the sampling period exceeds 8 hours, sampling may be conducted beyond the 6:00 a.m. to 6:00 p.m. period.
20. EPA - means the United States Environmental Protection Agency.

21. Federal Water Pollution Control Act (FWPCA) - means 33 U.S.C. §§1251 et. seq., as amended.
22. Flow – means the total volume of discharge in a 24-hour period.
23. Geometric Mean - means the Nth root of the product of the individual values of any set of values where N is equal to the number of individual values. The geometric mean is equivalent to the antilog of the arithmetic mean of the logarithms of the individual values. For purposes of calculating the geometric mean, values of zero (0) shall be considered one (1).
24. Grab Sample - means a single influent or effluent portion which is not a composite sample. The sample(s) shall be collected at the period(s) most representative of the discharge.
25. Indirect Discharger - means a nondomestic discharger who discharges pollutants to a publicly owned treatment works or a privately owned treatment facility operated by another person.
26. Industrial User - means those industries identified in the Standard Industrial Classification manual, Bureau of the Budget 1967, as amended and supplemented, under the category “Division D – Manufacturing” and such other classes of significant waste producers as, by regulation, the Director deems appropriate.
27. mg/L - means milligrams per liter of discharge.
28. MGD - means million gallons per day.
29. Monthly Average - means, other than for E. coli bacteria, the arithmetic mean of all the composite or grab samples taken for the daily discharges collected in one month period. The monthly average for E. coli bacteria is the geometric mean of daily discharge samples collected in a one month period. The monthly average for flow is the arithmetic mean of all flow measurements taken in a one month period. (Zero discharges shall not be included in the calculation of monthly averages.)
30. New Discharger - means a person owning or operating any building, structure, facility or installation:
 - a. From which there is or may be a discharge of pollutants;
 - b. From which the discharge of pollutants did not commence prior to August 13, 1979, and which is not a new source; and
 - c. Which has never received a final effective NPDES Permit for dischargers at that site.
31. New Source - means:
 - a. A new source as defined for coal mines by 40 CFR Part 434.11 (1994); and
 - b. Any building, structure, facility, or installation from which there is or may be a discharge of pollutants, the construction of which commenced:
 - (1) After promulgation of standards of performance under Section 306 of FWPCA which are applicable to such source; or
 - (2) After proposal of standards of performance in accordance with Section 306 of the FWPCA which are applicable to such source, but only if the standards are promulgated in accordance with Section 206 within 120 days of their proposal.
32. NH₃-N - means the pollutant parameter ammonia, measured as nitrogen.

33. 1-year, 24-hour precipitation event - means the maximum 24-hour precipitation event with a probable recurrence interval of once in one year as defined by the National Weather Service and Technical Paper No. 40, "Rainfall Frequency Atlas of the U.S.," May 1961, or equivalent regional or rainfall probability information developed therefrom.
34. Permit application - means forms and additional information that are required by ADEM Admin. Code r. 335-6-6-.08 and applicable permit fees.
35. Point Source - means "any discernible, confined and discrete conveyance, including but not limited to any pipe, channel, ditch, tunnel, conduit, well, discrete fissure, container, rolling stock, concentrated animal feeding operation, or vessel or other floating craft from which pollutants are or may be discharged." Section 502(14) of the FWPCA, 33 U.S.C. §1362(14).
36. Pollutant - includes for purposes of this Permit, but is not limited to, those pollutants specified in Code of Alabama 1975, §22-22-1(b)(3) and those effluent characteristics, excluding flow, specified in Part I.A. of this Permit.
37. Pollutant of Concern - means those pollutants for which a water body is listed as impaired or which contribute to the listed impairment.
38. Pollution Abatement and/or Prevention Plan (PAP Plan) – mining operations plan developed to minimize impacts on water quality to avoid a contravention of the applicable water quality standards as defined in ADEM Admin. Code r. 335-6-9-.03
39. Preparation, Dry - means a dry preparation facility within which the mineral/material is cleaned, separated, or otherwise processed without use of water or chemical additives before it is shipped to the customer or otherwise utilized. A dry preparation plant includes all ancillary operations and structures necessary to clean, separate, or otherwise process the mineral/material, such as storage areas and loading facilities. Dry preparation also includes minor water spray(s) used solely for dust suppression on equipment and roads to minimize dust emissions.
40. Preparation, Wet - means a wet preparation facility within which the mineral/material is cleaned, separated, or otherwise processed using water or chemical additives before it is shipped to the customer or otherwise utilized. A wet preparation plant includes all ancillary operations and structures necessary to clean, separate, or otherwise process the mineral/material, such as storage areas and loading facilities. Wet preparation also includes mineral extraction/processing by dredging, slurry pumping, etc.
41. Privately Owned Treatment Works - means any devices or system which is used to treat wastes from any facility whose operator is not the operator of the treatment works, and which is not a "POTW".
42. Publicly Owned Treatment Works (POTW) - means a wastewater collection and treatment facility owned by the State, municipality, regional entity composed of two or more municipalities, or another entity created by the State or local authority for the purpose of collecting and treating municipal wastewater.
43. Receiving Stream - means the "waters" receiving a "discharge" from a "point source".
44. Severe property damage - means substantial physical damage to property, damage to the treatment facilities which causes them to become inoperable, or substantial and permanent loss of natural resources which can reasonably be expected to occur in the absence of a bypass. Severe property damage does not mean economic loss caused by delays in production.
45. 10-year, 24-hour precipitation event - means that amount of precipitation which occurs during the maximum 24-hour precipitation event with a probable recurrence interval of once in ten years as

defined by the National Weather Service and Technical Paper No. 40, "Rainfall Frequency Atlas of the U.S.," May 1961, or equivalent regional or rainfall probability information developed therefrom.

46. TKN - means the pollutant parameter Total Kjeldahl Nitrogen.
47. TON - means the pollutant parameter Total Organic Nitrogen.
48. TRC - means Total Residual Chlorine.
49. TSS – means the pollutant parameter Total Suspended Solids
50. Treatment facility and treatment system - means all structures which contain, convey, and as necessary, chemically or physically treat mine and/or associated preparation plant drainage, which remove pollutants limited by this Permit from such drainage or wastewater. This includes all pipes, channels, ponds, tanks, and all other equipment serving such structures.
51. 24HC - means 24-hour composite sample, including any of the following:
 - a. The mixing of at least 12 equal volume samples collected at constant time intervals of not more than 2 hours over a period of 24 hours;
 - b. A sample collected over a consecutive 24-hour period using an automatic sampler composite to one sample. As a minimum, samples shall be collected hourly and each shall be no more than one twenty-fourth (1/24) of the total sample volume collected; or
 - c. A sample collected over a consecutive 24-hour period using an automatic composite sampler composited proportional to flow.
52. 24-hour precipitation event - means that amount of precipitation which occurs within any 24-hour period.
53. 2-year, 24-hour precipitation event - means the maximum 24-hour precipitation event with a probable recurrence interval of once in two years as defined by the National Weather Service and Technical Paper No. 40, "Rainfall Frequency Atlas of the U.S.," May 1961, or equivalent regional or rainfall probability information developed therefrom.
54. Upset - means an exceptional incident in which there is an unintentional and temporary noncompliance with technology-based permit discharge limitations because of factors beyond the control of the Permittee. An upset does not include noncompliance to the extent caused by operational error, improperly designed treatment facilities, inadequate facilities, lack of preventive maintenance, or careless or improper operation.
55. Waters - means "[a]ll waters of any river, stream, watercourse, pond, lake, coastal, ground or surface water, wholly or partially within the State, natural or artificial. This does not include waters which are entirely confined and retained completely upon the property of a single individual, partnership, or corporation unless such waters are used in interstate commerce." Code of Alabama 1975, §22-22-1(b)(2). "Waters" include all "navigable waters" as defined in §502(7) of the FWPCA, 33 U.S.C. §1362(7), which are within the State of Alabama.
56. Week - means the period beginning at twelve midnight Saturday and ending at twelve midnight the following Saturday.
57. Weekly (7-day and calendar week) Average – is the arithmetic mean of all samples collected during a consecutive 7-day period or calendar week, whichever is applicable. The calendar week is defined as beginning on Sunday and ending on Saturday. Weekly averages shall be calculated for all calendar weeks with Saturdays in the month. If a calendar week overlaps two months (i.e., the

Sunday is in one month and the Saturday in the following month), the weekly average calculated for the calendar week shall be included in the data for the month that contains the Saturday.

E. SEVERABILITY

The provisions of this Permit are severable, and if any provision of this Permit or the application of any provision of this Permit to any circumstance, is held invalid, the application of such provision to other circumstances, and the remainder of this Permit, shall not be affected thereby.

F. PROHIBITIONS AND ACTIVIES NOT AUTHORIZED

1. Discharges from disposal or landfill activities as described in ADEM Admin. Code div. 335-13 are not authorized by this Permit unless specifically approved by the Department.
2. Relocation, diversion, or other alteration of a water of the State is not authorized by this Permit unless specifically approved by the Department.
3. Lime or cement manufacturing or production and discharge of process waters from such manufacturing or production is not authorized by this Permit unless specifically approved by the Department.
4. Concrete or asphalt manufacturing or production and discharge of process waters from such manufacturing or production is not authorized by this Permit unless specifically approved by the Department.
5. The discharge of wastewater, generated by any process, facility, or by any other means not under the operational control of the Permittee or not identified in the application for this Permit or not identified specifically in the description of an outfall in this Permit is not authorized by this Permit.

G. DISCHARGES TO IMPAIRED WATERS

1. This Permit does not authorize new sources or new discharges of pollutants of concern to impaired waters unless consistent with an EPA-approved or EPA-established Total Maximum Daily Load (TMDL) and applicable State law, or unless compliance with the limitations and requirements of the Permit ensure that the discharge will not contribute to further degradation of the receiving stream. Impaired waters are those that do not meet applicable water quality standards and are identified on the State of Alabama's §303(d) list or on an EPA-approved or EPA-established TMDL. Pollutants of concern are those pollutants for which the receiving water is listed as impaired or contribute to the listed impairment.
2. Facilities that discharge into a receiving stream which is listed on the State of Alabama's §303(d) list of impaired waters, and with discharges that contain the pollutant(s) for which the waters are impaired, must within six (6) months of the Final §303(d) list approval, document in its BMP plan how the BMPs will control the discharge of the pollutant(s) of concern, and must ensure that there will be no increase of the pollutants of concern. A monitoring plan to assess the effectiveness of the BMPs in achieving the allocations must also be included in the BMP plan.
3. If the facility discharges to impaired waters as described above, it must determine whether a TMDL has been developed and approved or established by EPA for the listed waters. If a TMDL is approved or established during this Permit cycle by EPA for any waters into which the facility discharges, the facility must review the applicable TMDL to see if it includes requirements for control of any water discharged by the Permittee. Within six (6) months of the date of TMDL approval or establishment, the facility must notify the Department on how it will modify its BMP plan to include best management practices specifically targeted to achieve the allocations prescribed

by the TMDL, if necessary. Any revised BMP plans must be submitted to the Department for review. The facility must include in the BMP plan a monitoring component to assess the effectiveness of the BMPs in achieving the allocations.

H. COASTAL ZONE MANAGEMENT

1. Except for those activities described in Part III.H.2., this Permit is conditionally consistent with the Alabama Coastal Area Management Plan (ACAMP) upon continued compliance with the ACAMP.
2. The Permittee must apply for and obtain separate Coastal Area Management Plan Certification if any activity constitutes a Major Project as defined by ADEM Admin. Code ch. 335-8-1.

**ALABAMA DEPARTMENT OF ENVIRONMENTAL MANAGEMENT
WATER DIVISION**

NPDES INDIVIDUAL PERMIT RATIONALE

Company Name: Vulcan Construction Materials, LLC

Facility Name: Atmore Sand and Gravel

County: Escambia

Permit Number: AL0059498

Prepared by: Robert Glover

Date: January 2, 2024

Receiving Waters: Unnamed Tributary to Sizemore Creek

Permit Coverage: Construction Sand and Gravel, Wet Preparation, Transportation and Storage and Associated Areas

SIC Code: 1442

The Department has made a tentative determination that the available information is adequate to support reissuance of this permit.

This proposed permit covers construction sand and gravel, wet preparation, transportation and storage and associated areas which discharge to surface waters of the state.

The proposed permit authorizes treated discharges into an unnamed tributary to Sizemore Creek classified as Swimming (S) and Fish and Wildlife (F&W) per ADEM Admin. Code ch. 335-6-11. If the requirements of the proposed permit are fully implemented, the facility will not discharge pollutants at levels that will cause or contribute to a violation of the S and F&W classifications.

Full compliance with the proposed permit terms and conditions is expected to be protective of instream water quality and ensure consistency with applicable instream State water quality standards (WQS) for the receiving stream.

Technology Based Effluent Limits (TBELs) for construction sand and gravel facilities can be found in 40 CFR 436.32(1) and (2) for facilities that recycle waste water for use in processing and mine dewatering, respectively. The TBELs were promulgated for existing dischargers using the Best Practicable Control Technology Available (BPT). New Source Performance Standards (NSPS) have not yet been developed by the EPA for the construction sand and gravel subcategory.

40 CFR 436.32 includes the TBEL of 6.0 – 9.0 s.u. for pH. However the instream WQS for pH, for streams classified as Swimming (S) and Fish and Wildlife (F&W), are 6.0 - 8.5 s.u per ADEM Admin Code r. 335-6-10-.09. Information provided in the Permittee's application indicated that the discharge may occur during low flow conditions when the discharge/stream flow ratio may be high; therefore, discharge limitations for

pH of 6.0 – 8.5 s.u. are proposed for the Outfall per ADEM Admin Code r. 335-6-10-.09. This is a change for all outfalls from the previous permit. Under no circumstances may the discharge from the outfall cause the in-stream pH to deviate more than 1.0 s.u. from the normal or natural pH, nor be less than 6.0 s.u. nor greater than 8.5 s.u.

The TBELs for 40 CFR 436 Subpart C do not include limitations for Total Suspended Solids (TSS). TSS is classified as a conventional pollutant in 40 CFR 401.16 and is expected to be discharged from this type of facility. Therefore, monthly average and daily maximum effluent limitations for TSS were prepared using Best Professional Judgment (BPJ) with consideration given to the NSPS for TSS in 40 CFR 434.35.

The applicant has requested, in accordance with 40 CFR Part 122.21 and their NPDES permit application, a waiver from testing for the Part A, B, and C pollutants listed in the EPA Form 2C and 2D that are not addressed in their application. They have also certified that due to the processes involved in their mining activity these pollutants are believed to be not present in the waste stream.

The Pollution Abatement/Prevention (PAP) plan for this facility has been prepared by a professional engineer (PE) registered in the State of Alabama and is designed to ensure reduction of pollutants in the waste stream to a level that, if operated properly, the discharge will not contribute to or cause a violation of applicable State WQS. The proposed permit terms and conditions are predicated on the basis of ensuring a reduction of pollutants in the discharge to a level that reduces the potential of contributing to or causing a violation of applicable State WQS.

In accordance with ADEM Admin. Code r. 335-6-3-.07 the design PE, as evidenced by their seal and/or signature on the application, has accepted full responsibility for the effectiveness of the waste treatment facility to treat the Permittee's effluent to meet NPDES permit limitations and requirements, and to fully comply with Alabama's WQS, when such treatment facilities are properly operated.

If there is a reasonable potential that a pollutant present in the treated discharges from a facility could cause or contribute to a contravention of applicable State WQS above numeric or narrative criteria, 40 CFR Part 122 requires the Department to establish effluent limits using calculated water quality criterion, establish effluent limits on a case-by-case basis using criteria established by EPA, or establish effluent limits based on an indicator parameter. Based on available information, potential pollutants discharged from this facility, if discharged within the concentrations allowed by this permit, would not have a reasonable potential to cause or contribute to a contravention of applicable State WQS.

Pursuant to ADEM Admin. Code r. 335-6-6-.12(r) this permit requires the Permittee to design and implement a Spill Prevention Control and Countermeasures (SPCC) plan for all stored chemicals, fuels and/or stored pollutants that have the potential to discharge to a water of the State. This plan must meet the minimum engineering requirements as defined in 40 CFR Part 112 and must provide for secondary containment adequate to control a potential spill.

The applicant is not proposing discharges of pollutants to a water of the State with an approved Total Maximum Daily Load (TMDL).

The applicant is proposing discharges into an unnamed tributary to Sizemore Creek, which is a stream segment or other State water that is included on Alabama's current CWA §303(d) list for Pathogens (E. Coli). This type of pollutant is not expected in significant concentrations from a facility of this type. If the requirements of the proposed permit and pollution abatement plan are fully implemented, there is reasonable assurance that the facility will not discharge pollutants at levels that will cause or contribute to any further impairment of Sizemore Creek.

The applicant is not proposing new discharges of pollutant(s) to an ADEM identified Tier I water.

The proposed permit does not authorize new or increased discharges of pollutants to a Tier II water. Therefore, the Antidegradation Policy (ADEM Admin. Code 335-6-10-.04) does not apply to this permit.

NPDES Individual Permit - Modification/Reissuance - Mining (Form 315)

version 3.6

(Submission #: HPM-11TE-C8Z4Z, version 1)

Digitally signed by:
GlobalSign RSA OV SSL CA 2018
Date: 2022.09.19 11:44:40 -05:00
Reason: Submission Data
Location: State of Alabama

Details

Submission ID HPM-11TE-C8Z4Z

Form Input

General Instructions

NPDES Individual Application - Mining and Coalbed Methane Operations - Mod/Reissuance (Form 315/549)

PLEASE CONTACT YOUR ASSIGNED PERMIT CONTACT TO DISCUSS THE TYPE OF MODIFICATION YOU SHOULD APPLY FOR BEFORE COMPLETING THIS FORM.

This form should be used to submit the following permit requests for individually permitted Mining and Coalbed Methane Operations:

Modifications/Reissuances that include Permit Transfers and/or Permittee/Facility Name Changes
Minor Modifications
Major Modifications
Reissuances
Reissuance of a permit on or after the current permit's expiration date
Revocation and Reissuance before the current permit's expiration date

Please complete all questions and attach all necessary documentation as prompted throughout the application process. Incomplete or incorrect information will delay processing.

Applicable Fees:

Minor Modifications

\$3,400 (Mineral/Resource Extraction Mining, Storage Transloading, Dry Processing)

\$3,940 (Wet Preparation, Processing, Beneficiation)

\$3,940 (Coalbed Methane Operations)

Major Modifications

\$5,820 (Mineral/Resource Extraction Mining, Storage Transloading, Dry Processing)

\$6,860 (Wet Preparation, Processing, Beneficiation)

\$6,860 (Coalbed Methane Operations)

Reissuances

\$5,820 (Mineral/Resource Extraction Mining, Storage Transloading, Dry Processing)

\$6,860 (Wet Preparation, Processing, Beneficiation)

\$6,860 (Coalbed Methane Operations)

Potential Add-on Fees for Major Modifications and Reissuances

\$1,015 (Biomonitoring & Toxicity Limits)

\$2,705 (Review of Model Performed by Others)

\$4,855 (Modeling ♦ desktop)

[For assistance, please click here to determine the permit staff responsible for the site or call \(334\) 394-4372.](#)

Processing Information

Purpose of Application

Reissuance of Permit Due to Approaching Expiration

Please indicate if the Permittee is applying for a permit transfer and/or name change in addition to permit modification or reissuance:

None

Action Type

Reissuance

Briefly describe any planned changes at the facility that are included in this reissuance application:

None

Is this a coalbed methane operation?

No

Permit Information

Permit Number

AL0059498

Current Permittee Name

Vulcan Construction Materials, LLC

Permittee

Permittee Name

Vulcan Construction Materials, LLC

Mailing Address

1200 Urban Center Drive
Birmingham, Alabama 35242

Responsible Official

Prefix

Mr.

First Name

David

Last Name

Langer

Title

Vice President Operations Southern and Gulf Coast Region

Organization Name

Vulcan Construction Materials, LLC

Phone Type

Business

Number

2052984200

Extension

Email

langnerd@vmcmail.com

Mailing Address

1200 Urban Center Drive
Birmingham, AL 35242

Existing Permit Contacts

Affiliation Type	Contact Information	Remove?
Authorized Rep	Clarence Specht	NONE PROVIDED
DMR Contact	Clarence Specht	Keep
Environmental Contact	Clarence Specht	NONE PROVIDED
Notification Recipient,Responsible Official	John T. Clark, Atmore Sand and Gravel	Remove
Permittee	Vulcan Construction Materials, LLC	NONE PROVIDED

Facility/Operations Information

Facility/Operations Name

Atmore Sand and Gravel

Permittee Organization Type

LLC

Parent Corporation and Subsidiary Corporations of Applicant, if any:

NONE PROVIDED

Landowner(s) Name, Address and Phone Number:

Escambia Sand and Gravel Company

Sub-contractor(s)/Operator(s), if known:

Vulcan Construction Materials, LLC

Is the Company/Permittee properly registered and in good standing with the Alabama Secretary of State's office?

Yes

Facility/Operations Address or Location Description

1090 Old Jack Springs Road

Atmore, AL 36502

Facility/Operations County (Front Gate)

Escambia

Do the operations span multiple counties?

No

Detailed Directions to the Facility/Operations

From I-65, take Exit 54, proceed west approximately 1.5 miles. Turn right onto Jack Springs Road at the Frontier Communication substation. Follow Old Jack Springs Road approximately one mile to the plant entrance.

Please refer to the link below for Lat/Long map instruction help:

[Map Instruction Help](#)

Facility/Operations Front Gate Latitude and Longitude

31.10185800000000,-87.53456900000001

Township(s), Range(s), Section(s) (Note: If you are submitting multiple TRSs, please separate each TRS by a semicolon. Example: T19S,R1E,S15; T20S,R2E,S16)

T 2N, R 5E, Sec 26 and 35

SIC Code(s) [Please select your primary SIC code first]:

1442-Construction Sand and Gravel

NAICS Code(s) [Please select your primary NAICS code first]:

212321-Construction Sand and Gravel Mining

Facility/Operations Contact

Prefix

Mr.

First Name Last Name

Robert Kilgore

Title

Plant Manager

Organization Name

Vulcan Materials Company

Phone Type Number Extension

Business 2514320572

Email

kilgorer@vmcmail.com

Member Information

Identify the name, title/position, and unless waived in writing by the Department, the resident address of every officer (a PO Box is not acceptable), general partner, LLP partner, LLC member, investor, director, or person performing a function similar to a director, of the applicant, and each person who is the record or beneficial owner of 10 percent or more of any class of voting stock of the applicant, or any other responsible official(s) of the applicant with legal or decision making responsibility or authority for the facility/operations (if this does not apply, then enter N/A after selecting "Manually Enter in Table"):

List of Names/Titles/Addresses will be entered by:

Providing as an Attachment

Provide a list of names with titles and addresses as an attachment.

[VMC Directors-Officers \(Updated Jul-2021\).pdf - 08/26/2022 05:18 PM](#)

Comment

NONE PROVIDED

Other than the "Company/Permittee", identify the name of each corporation, partnership, association, and single proprietorship for which any individual identified above is or was an officer, general partner, LLP partner, LLC member, investor, director, or individual performing a function similar to a director, or principal (10% or more) stockholder, that had an Alabama NPDES permit at any time during the five year (60 month) period immediately preceding the date on which this form is signed (if this does not apply, then enter N/A after selecting "Manually Enter in Table"):

List of Corporations/Partnerships/etc, Names and Titles will be entered by:

Providing as an Attachment

Provide a list of corporation, partnership etc. and the name and title as an attachment.

[VMC Directors-Officers \(Updated Jul-2021\).pdf - 09/07/2022 12:24 PM](#)

Comment

NONE PROVIDED

Additional Contacts (1 of 1)

ADDITIONAL CONTACTS: Environmental Contact

Contact Type

Environmental Contact

Contact

First Name	Last Name	
Clarence	Specht	
Title		
Environmental Specialist		
Organization Name		
NONE PROVIDED		
Phone Type	Number	Extension
Business	2057184723	
Email		
spechtc@vmcmail.com		
Address		
1200 URBAN CENTER DR		
VESTAVIA, AL 35242		

Compliance History

Has the applicant ever had any of the following:

Event	Apply?
An Alabama NPDES, SID, or UIC permit suspended or terminated	No
An Alabama or federal environmental permit suspended/terminated	No
An Alabama State Oil Gas Board permit or other approval suspended or terminated	No
An Alabama or federal performance/environmental bond, or similar security deposited in lieu of a bond, or portion thereof, forfeited	No

Has the applicant, parent corporation, subsidiary, general partner, LLP partner, or LLC Member had any Warning Letters, Notice of Violations (NOVs), Administrative Actions, or litigation filed by ADEM or EPA during the three year (36 month) period preceding the date on which this form is signed?

Yes

Identify every Warning Letter, Notice of Violation (NOV), Administrative Action, or litigation issued to the applicant, parent corporation, subsidiary, general partner, LLP partner, or LLC Member and filed by ADEM or EPA during the three year (36 month) period preceding the date on which this form is signed.

Date of Issuance	Type of Action	Briefly describe alleged violations:	Date of Final Resolution
8/10/2022	Warning Letter	Warning letter based on unannounced air inspection. No permit conditions were violated	8/25/2022
4/14/2020	Warning Letter	Discharge of Turbid water. Failure of storm water system pump during heavy rainfall event.	4/27/2020

For this facility, list any other NPDES or other environmental permits (including permit numbers), authorizations, or certifications that have been applied for or issued within the State by ADEM, EPA, Alabama Department of Labor (ADOL), US Army Corp of Engineers (USACE), or other agency, to the applicant, parent corporation, subsidiary, or LLC member whether presently effective, expired, suspended, revoked, or terminated:

Alabama Department of Labor Permit # 016450

For other facilities, list any other NPDES or other ADEM permits (including permit numbers), authorizations, or certifications that have been applied for or issued within the State by ADEM, EPA, ASMC, ADOL, or USACE, to the applicant, parent corporation, subsidiary, or LLC member whether presently effective, expired, suspended, revoked, or terminated:

AIR: Black Bottom Asphalt (Hanceville) 702-0054-ADEM; Calera Qry, 411-0011-ADEM; Centre Asphalt, 303-0004-ADEM; Cherokee Qry, 701-0014-ADEM; Childersburg Qry, 309-0028-ADEM; Coldwater Quarry, 301-0051-ADEM; Eastaboga Asphalt, 309-0041-ADEM; Fort Payne Qry, 703-0001-ADEM; Glencoe Asphalt, 307-0021-ADEM; Glencoe Qry, 307-0011-ADEM; Grant Qry, 711-0052-ADEM; Gurley Qry, 709-0022-ADEM; Helena Qry, 411-0010-ADEM; Lacon Qry, 712-0014-ADEM; Notasulga I Qry, 206-0043-ADEM; Notasulga II Qry, 206-0039-ADEM; Ohatchee Qry, 301-0045-ADEM; Pride Qry, 701-0048-ADEM; Roberta Qry, 411-0028-ADEM; Scottsboro Qry, 705-0005-ADEM; South Russellville Qry, 704-0014-ADEM; Speedway Qry, 309-0041-ADEM; Springville Qry, 410-0024-ADEM; Trinity Qry, 712-0012-ADEM; Turkeytown Asphalt, 307-0035-ADEM; Tuscaloosa Qry, 413-0074-ADEM; Tuscumbia Qry, 701-0017-ADEM; Village Springs Qry, 402-0015-ADEM.

WATER: Bay Bridge Yard, ALG230068; Bessemer Qry, AL0069035; Black Bottom Asphalt, ALG020226; Blakeley Island Yard, ALG230064; Calera Qry, AL0002046; Centre Asphalt, ALG020036; Cherokee Qry, AL0056391; Childersburg Qry, AL0002313; Coldwater Qry, AL0069892; Collinsville Qry, AL0083534; Dolcito Qry, AL0023892; Eastaboga Asphalt, ALG020037; Fort Payne Qry, AL0055778; Glencoe Asphalt, ALG020039; Glencoe Qry, AL0002020; Grant Qry, AL0075698; Gurley Qry, AL0075507; Helena Qry, AL0001996; Huntsville Qry, AL0055964; Keener Qry, AL0073032; Lacon Qry, AL0041891; Lakeshore Qry, AL0074888; N Birmingham Qry, AL0077658; Notasulga (I), AL0074969; Notasulga (II), AL0074357; Ohatchee Qry, AL0002186; Pride Qry, AL0072036; Roberta Qry, AL0053601; Rock Spring Qry, AL0076996; Scottsboro Qry, AL0000256; S Russellville Qry, AL0072117; Speedway Qry, AL0066320; Springville Qry, AL0072214; Trinity Qry, AL0041921; Tuscaloosa Qry, AL0070459; Tuscumbia Qry, AL0000264; Village Springs Qry, AL0075108

MINING: Atmore Sand and Gravel, 30-Vulcan-1; Coldwater Qry, 11-Vulcan-1; Notasulga II Qry, 43-Vulcan-2

Anti-Degradation Evaluation

Pursuant to ADEM Admin. Code ch. 335-6-10-.12(9), responses to the following questions must be provided by the applicant requesting NPDES permit coverage for new or expanded discharges of pollutant(s) to Tier 2 waters (except discharges eligible for coverage under general permits). As part of the permit application review process, the Department is required to consider, based on the applicant's demonstration, whether the proposed new or increased discharge to Tier 2 waters is necessary for important economic or social development in the area in which the waters are located. Does this modification/reissuance include a new outfall?

No

Activity Description & Information

Narrative description of activity(s):

When operating this facility will employ 8 people on a full-time, basis and will produce mined sand and gravel. Typical operating hours are 4am to 4pm, 5 days a week. The site is comprised of some 513 drainage acres, approximately 300 of which is disturbed and made up of the sand and gravel processing areas, equipment storage and fueling areas, spoil and stockpile storage areas, haul roads, and quarry pit.

Total Facility/Operations Area (acres)

513.00

Total Disturbed Area (acres)

300.00

Anticipated Commencement Date

3/31/2023

Anticipated Completion Date

3/31/2027

Please identify which of the following apply to this operation:

Activity/Condition	Apply?
An existing facility/operation which currently results in discharges to State waters?	No
A proposed facility/operation which will result in a discharge to State waters?	No
Be located within any 100-year flood plain?	No
Discharge to Municipal Separate Storm Sewer?	No
Discharge to waters of or be located in the Coastal Zone?	No
Need/have ADEM UIC permit coverage?	No
Be located on Indian/historically significant lands?	No
Need/have ADEM SID permit coverage?	No
Need/have ASMC permit coverage?	No
Need/have State Oil & Gas Board permit coverage?	No
Need/have ADOL permit coverage?	Yes
Generate, treat, store, or dispose of hazardous or toxic waste?	No
Be located in or discharge to a Public Water Supply (PWS) watershed or be located within 1/4 mile of any PWS well?	No
Incised pit	No

Does your facility/operation use cooling water?

No

Material to be Removed, Processed, or Transloaded

Material To Be Removed, Processed, Or Transloaded (Note: Sum must equal 100.)

Mineral(s)/Mineral product(s)	%
Sand and/or Gravel	100
	Sum: 100

Proposed Activity To Be Conducted

Type(s) of activity presently conducted at applicant's existing facility or proposed to be conducted at facility (Select Yes or No):

Activity	Apply?
Adjacent/associated asphalt/concrete plant(s)	No
Alternative fuels operation	No
Auger mining	No
Cement production	No
Chemical processing or leaching	No
Chemicals used in process or wastewater treatment (coagulant, biocide, etc.)	No
Construction related temporary borrow pits/areas	No
Creek/stream crossings	No
Excavation	No
Grading, clearing, grubbing, etc.	No
Hydraulic mining	Yes
Hydraulic mining, dredging, instream or between stream-bank mining	No
Lime production	No
Low volume sewage treatment package plant	No
Mineral dry processing (crushing & screening)	No
Mineral loading	Yes
Mineral storing	Yes
Mineral transportation	Yes
Mineral wet preparation	Yes
Onsite construction debris or equipment storage/disposal	No
Onsite mining debris or equipment storage/disposal	No
Other beneficiation & manufacturing operations	No
Pre-construction ponded water removal	No
Pre-mining logging or land clearing	No
Preparation plant waste recovery	No
Quarrying	No
Reclamation of disturbed areas	Yes
Solution mining	No
Surface mining	Yes
Synthetic fuel production	No
Underground mining	No
Waterbody relocation or other alteration	No
Within-bank mining	No

If the operation will include activities other than those listed above, please describe them below:

NONE PROVIDED

If the type of activity presently conducted or proposed is Mineral Transportation, please indicate which of the following apply:

Barge	Apply?
Barge	No
Rail	No
Truck	Yes

Fuel - Chemical Handling, Storage, & Spill Prevention Control & Countermeasures (SPCC) Plan

Will fuels, chemicals, compounds, or liquid waste be used or stored onsite?

No

ASMC Regulated Entities

Is this a coal mining operation regulated by ASMC?

No

Topographic Map Submittal

Topographic Map

Attach to this application a 7.5 minute series U.S.G.S. topographic map(s) or equivalent map(s) no larger than, or folded to a size of 8.5 by 11 inches (several pages may be necessary), of the area extending to at least one mile beyond property boundaries. The topographic or equivalent map(s) must include a caption indicating the name of the topographic map, name of the applicant, facility name, county, and township, range, & section(s) where the facility are located. Unless approved in advance by the Department, the topographic or equivalent map(s), at a minimum, must show: a) An accurate outline of the area to be covered by the permit (b) An outline of the facility (c) All existing and proposed disturbed areas (d) Location of intake and discharge areas (e) Proposed and existing discharge points (f) Perennial, intermittent, and ephemeral streams (g) Lakes, springs, water wells, wetlands (h) All known facility dirt/improved access/haul roads (i) All surrounding unimproved/improved roads (j) High-tension power lines and railroad tracks (k) Contour lines, township-range-section lines (l) Drainage patterns, swales, washes (m) All drainage conveyance/treatment structures (ditches, berms, etc.) (n) Any other pertinent or significant feature.

Topographic Map

[Atmore_Topo_11x17.pdf - 09/02/2022 02:32 PM](#)

Comment

NONE PROVIDED

Detailed Facility Map Submittal

Detailed Facility Map

[Atmore_Image_18x24.pdf - 09/02/2022 02:33 PM](#)

Comment

NONE PROVIDED

Outfalls (1 of 1)

Outfall Identifier: 001

Feature Type

Outfall (External)

Outfall Identifier

001

Outfall Status

Existing

Permit Action

Reissue

Receiving Water

Sizemore Creek

Check below if the discharge enters the receiving water via an unnamed tributary.

Unnamed Tributary

Location of Outfall

31.1018580000000, -87.5345690000001

Are the location coordinates above still correct for this outfall?

Yes

Distance to Receiving Water (ft)

200

Disturbed Area (acres)

373

Drainage Area (acres)

383

303(d) Segment?

No

TMDL Segment?

No

Please do not add a new outfall unless you are requesting a modification that includes a new outfall. All of the currently permitted outfalls are already included in this form. If you add an outfall in error, please choose **Delete** under **Permit Action** for the outfall. If you have any questions, please contact your permit engineer BEFORE proceeding.

Discharge Characterization**EPA Form 2C, EPA Form 2D, and/or ADEM Form 567 Submittal**

Yes, pursuant to 40 CFR 122.21, the applicant requests a waiver for completion of EPA Form 2C, EPA Form 2D, and ADEM Form 567 and certifies that the operating facility will discharge treated stormwater only; that chemical/compound additives are not used (unless waived in writing by the Department on a programmatic, categorical, or individual compound/chemical basis); that there are no process, manufacturing, or other industrial operations or wastewaters, including but not limited to lime or cement production and syngas operations; and that coal and coal products are not mined nor stored onsite.

Please download the following Excel file to enter your information. Once complete, please attach to the below control.

[Download spreadsheet here.](#)

Required attachment:

[Form315TableB.xlsx - 09/02/2022 02:35 PM](#)

Comment

NONE PROVIDED

Please download the following Excel file to enter your information. Once complete, please attach to the below control.

[Download spreadsheet here.](#)

Required attachment:

[Form315TableC.xlsx - 09/02/2022 02:35 PM](#)

Comment

NONE PROVIDED

Discharge Structure Description & Pollutant Source

Please download the following Excel file to enter your information. Once complete, please attach to the below control.

[Download spreadsheet here.](#)

Required attachment:

[Form315DischargeStructure.xlsx - 08/26/2022 05:55 PM](#)

Comment

NONE PROVIDED

Variance Request

Do you intend to request or renew one or more of the CWA technology variances authorized at 40 CFR 122.21(m)?
No

Pollution Abatement & Prevention (PAP) Plan Summary (1 of 1)

Outfall(s):
001E

Outfall Questions:	Please select one:
Runoff from all areas of disturbance is controlled	Yes
Drainage from pit area, stockpiles, and spoil areas directed to a sedimentation pond	Yes
Sedimentation basin at least 0.25 acre/feet for every acre of disturbed drainage	Yes
Sedimentation basin cleaned out when sediment accumulation is 60% of design capacity	Yes
Trees, boulders, and other obstructions removed from pond during initial construction	Yes
Width of top of dam greater than 12'	Yes
Side slopes of dam no steeper than 3:1	Yes
Cutoff trench at least 8' wide	Yes
Side slopes of cutoff trench no less than 1:1	Yes
Cutoff trench located along the centerline of the dam	Yes
Cutoff trench extends at least 2' into bedrock or impervious soil	Yes
Cutoff trench filled with impervious material	Yes
Embankments and cutoff trench 95% compaction standard proctor ASTM	Yes
Embankment free of roots, tree debris, stones >6" diameter, etc.	Yes
Embankment constructed in lifts no greater than 12"	Yes
Spillpipe sized to carry peak flow from a one year storm event	Yes
Spillpipe will not chemically react with effluent	Yes
Subsurface withdrawal	Yes
Anti-seep collars extend radially at least 2' from each joint in spillpipe	Yes
Splashpad at the end of the spillpipe	Yes
Emergency Spillway sized for peak flow from 25-yr 24-hr event if discharge not into PWS classified stream	Yes
Emergency spillway sized for peak flow from 50-yr 24-hr event if discharge is into PWS classified stream	N/A
Emergency overflow at least 20' long	Yes
Side slopes of emergency spillway no steeper than 2:1	Yes
Emergency spillway lined with riprap or concrete	Yes
Minimum of 1.5' of freeboard between normal overflow and emergency overflow	Yes
Minimum of 1.5' of freeboard between max. design flow of emergency spillway and top of dam	Yes
All emergency overflows are sized to handle entire drainage area for ponds in series	Yes
Dam stabilized with permanent vegetation	Yes
Sustained grade of haul road <10%	Yes
Maximum grade of haul road <15% for no more than 300'	Yes
Outer slopes of haul road no steeper than 2:1	Yes
Outer slopes of haul road vegetated or otherwise stabilized	Yes
Detail drawings supplied for all stream crossings	N/A
Short-Term Stabilization/Grading And Temporary Vegetative Cover Plans	Yes
Long-Term Stabilization/Grading And Permanent Reclamation or Water Quality Remediation Plans	Yes

Identify and provide detailed explanation for any N or N/A response(s):

- Emergency spillway sized for peak flow from 50-yr 24-hr event if discharge is into PWS classified stream: -N/A- The facility does not discharge into a PWS classified stream
- Detail drawings supplied for all stream crossings: -N/A- The facility does not have any stream crossings.

Pollution Abatement & Prevention (PAP) Plan Review Checklist

General Information:	Please select one:
PE Seal with License #	Yes
Name and Address of Operator	Yes
Legal Description of Facility	Yes
Name of Company	Yes
Number of Employees	Yes
Products to be Mined	Yes
Hours of Operation	Yes
Water Supply and Disposition	Yes

Maps:	Please select one:
Topographic Map including Information from Part XIII (a) <input type="checkbox"/> (o) of this Application	Yes
<input type="checkbox"/> <input type="checkbox"/> 500 <input type="checkbox"/> or Equivalent Facility Map including Information from Part XIV of this Application	Yes

Detailed Design Diagrams:	Please select one:
Plan Views	Yes
Cross-section Views	Yes
Method of Diverting Runoff to Treatment Basins	Yes
Line Drawing of Water Flow through Facility with Water Balance or Pictorial Description of Water Flow	Yes

Narrative of Operations:	Please select one:
Raw Materials Defined	Yes
Processes Defined	Yes
Products Defined	Yes

Schematic Diagram:	Please select one:
Points of Waste Origin	Yes
Collection System	Yes
Disposal System	Yes

Post Treatment Quantity and Quality of Effluent:	Please select one:
Flow	Yes
Suspended Solids	Yes
Iron Concentration	N/A
pH	Yes

Identify and provide detailed explanation for any N or N/A response(s):

Iron Concentration: -N/A- Iron Concentration is not a pollutant that has been required by this permit.

Description of Waste Treatment Facility:	Please select one:
Pre-Treatment Measures	Yes

Description of Waste Treatment Facility:	Please select one:
Recovery System	Yes
Expected Life of Treatment Basin	Yes
Measures for Ensuring Access to All Treatment Structures and Related Appurtenances including Outfall Locations	Yes
Schedule of Cleaning and/or Abandonment	Yes

Other:	Please select one:
Precipitation/Volume Calculations/Diagram Attached	Yes
BMP Plan for Haul Roads	Yes
Measures for Minimizing Impacts to Adjacent Stream (e.g., Buffer Strips, Berms)	Yes
Measures for Ensuring Appropriate Setbacks are Maintained at All Times	Yes
Methods for Minimizing Nonpoint Source Discharges	Yes
If Chemical Treatment Used, Methods for Ensuring Appropriate Dosage	Yes
Facility Closure Plans	Yes
PE Rationale(s) For Alternate Standards, Designs or Plans	N/A

Identify and provide detailed explanation for any **N** or **N/A** response(s):

PE Rationale(s) For Alternate Standards, Designs or Plans: -N/A- There are no alternative standards, designs or plans outlined in the PAP

Pollution Abatement & Prevention (PAP) Plan

Is this a coal mining operation regulated by ASMC?

No

PAP Plan (non-coal mining facilities)

[Atmore PAP 2022.pdf - 09/02/2022 02:41 PM](#)

Comment

NONE PROVIDED

Professional Engineer (PE)

Registration License Number

17685

Professional Engineer

Prefix

Mr.

First Name Last Name

Thomas Young

Title

Professional Engineer

Organization Name

Vulcan Materials Company

Phone Type Number Extension

Business 205 298 4000

Email

youngto@vmcmail.com

Address

1200 Urban Center Drive

Birmingham, Alabama 35242

Information for the Applicant

Please read the following information and acknowledge below:

Contact the Department prior to submittal with any questions or to request acceptable alternate content/format.

Be advised that you are not authorized to commence regulated activity until this application can be processed, publicly noticed, and approval to proceed is received in writing from the Department.

EPA Form(s) 1 and 2F need not be submitted unless specifically required by the Department. EPA Form(s) 2C and/or 2D are required to be submitted unless the applicant is eligible for a waiver and the Department grants a waiver, or unless the relevant information required by EPA Form(s) 2C and/or 2D are submitted to the Department in an alternative format acceptable to the Department.

Planned/proposed mining sites that are greater than 5 acres, that mine/process coal or metallic mineral/ore, or that have wet or chemical processing, must apply for and obtain coverage under an Individual or General NPDES Permit prior to commencement of any land disturbance. Such Individual NPDES Permit coverage may be requested via this ADEM Form 315.

The applicant is advised to contact:

- (1) The Alabama Surface Mining Commission (ASMC) if coal, coal fines, coal refuse, or other coal related materials are mined, transloaded, processed, etc.;
- (2) The Alabama Department of Labor (ADOL) if conducting non-coal mining operations;
- (3) The Alabama Historical Commission for requirements related to any potential historic or culturally significant sites;
- (4) The Alabama Department of Conservation and Natural Resources (ADCNR) for requirements related to potential presence of threatened/endangered species;
- (5) The US Army Corps of Engineers, Mobile or Nashville Districts, if this project could cause fill to be placed in federal waters or could interfere with navigation.

The Department must be in receipt of a completed version of this form, including any supporting documentation, and the appropriate processing fee [including Greenfield Fee and Biomonitoring & Toxicity Limits fee(s), if applicable], prior to development of a draft NPDES permit.

Acknowledgement

I acknowledge I have read and understand the information above.

Additional Attachments

Additional Attachments

NONE PROVIDED

Comment

NONE PROVIDED

Application Preparer

Application Preparer**Prefix***NONE PROVIDED***First Name Last Name**Clarence *Specht***Title***Environmental Specialist***Organization Name***NONE PROVIDED***Phone Type Number Extension**

Business 2057184723

Email

spechtc@vmcmail.com

Address

1200 Urban Center Drive

Birmingham, AL 35242

Fees Assessed

The following itemized fees have been assessed in accordance with Fee Schedule D and 335-1-6-.04(a) of ADEM Admin. Code Division 1 regulations based on the information provided in this application.

If the correct fees are not displayed, please contact your permit engineer PRIOR to submitting the form. Do NOT answer questions erroneously in order to have the correct fee assessed.

Wet Preparation, Processing, Beneficiation:

6860

Fee**Fee**

6860

Agreements and Signature(s)

SUBMISSION AGREEMENTS

- I am the owner of the account used to perform the electronic submission and signature.
- I have the authority to submit the data on behalf of the facility I am representing.
- I agree that providing the account credentials to sign the submission document constitutes an electronic signature equivalent to my written signature.
- I have reviewed the electronic form being submitted in its entirety, and agree to the validity and accuracy of the information contained within it to the best of my knowledge.

Professional Engineer (PE)

A detailed, comprehensive Pollution Abatement & Prevention (PAP) Plan must be prepared, signed, and certified by a professional engineer (PE), registered in the State of Alabama, and the PE must certify as follows: I certify under penalty of law that the technical information and data contained in this application, and a comprehensive Pollution Abatement & Prevention (PAP) Plan, including any attached SPCC plan, maps, engineering designs, etc. acceptable to ADEM, for the prevention and minimization of all sources of pollution in stormwater and authorized related process wastewater runoff has been prepared under my supervision for this facility utilizing effective, good engineering and pollution control practices and in accordance with the provisions of this Permit, and ADEM Admin. Code Division 335-6, including Chapter 335-6-9 and Appendices A & B. If the PAP Plan is properly implemented and maintained by the Permittee, discharges of pollutants can reasonably be expected to be effectively minimized to the maximum extent practicable and according to permit discharge limitations and other permit requirements. The applicant has been advised that appropriate pollution abatement/prevention facilities and structural & nonstructural management practices or Department approved equivalent management practices as detailed in the PAP Plan must be fully implemented and regularly maintained as needed at the facility in accordance with good sediment, erosion, and other pollution control practices, permit requirements, and other ADEM requirements to ensure protection of groundwater and surface water quality.

Signed Thomas Young on 09/19/2022 at 11:35 AM
By

Responsible Official

This application must be signed and initialed by a Responsible Official of the applicant pursuant to ADEM Admin. Code Rule 335-6-6-.09 who has overall responsibility for the operation of the facility. I certify under penalty of law that this document, including technical information and data, the PAP Plan, including any SPCC plan, maps, engineering designs, and all other attachments were prepared under my direction or supervision in accordance with a system designed to assure that qualified personnel properly gathered and evaluated the information submitted. Based on my inquiry of the PE and other person or persons under my supervision who manage the system or those persons directly responsible for gathering the information, the information submitted is, to the best of my knowledge and belief, true, accurate, and complete. I am aware that there are significant penalties for submitting false information including the possibility of fine or imprisonment for knowing violations. A comprehensive PAP Plan to prevent and minimize discharges of pollution to the maximum extent practicable has been prepared at my direction by a PE for this facility utilizing effective, good engineering and pollution control practices and in accordance with the provisions of ADEM Admin. Code Division 335-6, including Chapter 335-6-9 and Appendices A & B, and information contained in this application, including any attachments. I understand that regular inspections must be performed by, or under the direct supervision of, a PE and all appropriate pollution abatement/prevention facilities and structural & nonstructural management practices or Department approved equivalent management practices identified by the PE must be fully implemented prior to and concurrent with commencement of regulated activities and regularly maintained as needed at the facility in accordance with good sediment, erosion, and other pollution control practices and ADEM requirements. I understand that the PAP Plan must be fully implemented and regularly maintained so that discharges of pollutants can reasonably be expected to be effectively minimized to the maximum extent practicable and according to permit discharge limitations and other requirements to ensure protection of groundwater and surface water quality. I understand that failure to fully implement and regularly maintain required management practices for the protection of groundwater and surface water quality may subject the Permittee to appropriate enforcement action. I certify that this form has not been altered, and if copied or reproduced, is consistent in format and identical in content to the ADEM approved form. I further certify that the discharges described in this application have been tested or evaluated for the presence of non-stormwater discharges and any non-mining associated beneficiation/process pollutants and wastewaters have been fully identified. I acknowledge my understanding that I may be required to obtain a permit from the ADOL. I acknowledge my understanding that if the proposed activities will be conducted in or potentially impact waters of the state or waters of the US (including wetlands), that I may be required to obtain a permit from the USACE.

Signed David Langner on 09/16/2022 at 6:46 AM
By

The applicant is required to supply outfall number(s) as it appears on the map(s) required by this application [if this application is for a modification to an existing permit do not change the numbering sequence of the permitted outfalls], describe each, (e.g., pipe, spillway, channel, tunnel, conduit, well, discrete fissure, or container), and identify the origin of pollutants. The response must be precise for each outfall. If the discharge of pollutants from any outfall is the result of commingling of waste streams from different origins, each origin must be completely described.

Description of Origin of Pollutants – typical examples: (1) Discharge of drainage from the underground workings of an underground coal mine, (2) Discharge of drainage from a coal surface mine, (3) Discharge of drainage from a coal preparation plant and associated areas, (4) Discharge of process wastewater from a gravel-washing plant, (5) Discharge of wastewater from an existing source coal preparation plant, (6) Discharge of drainage from a sand and gravel pit, (7) Pumped discharge from a limestone quarry, (8) Controlled surface mine drainage (pumped or siphoned), (9) Discharge of drainage from mine reclamation, (10) Other (please describe):

Outfall	Discharge structure Description	Description of Origin of pollutants	Surface Discharge	Groundwater Discharge	Wet Prep -Other Production Plant	Pumped or Controlled Discharge	Low Volume STP
001E	2-26 inch outlet pipes	4, 6, 8, 9, 10 (Storm water)	X	X	X	X	

The applicant is required to supply the following information separately for every proposed (P) or existing (E) outfall. List expected average daily discharge flow rate in cfs and gpd; frequency of discharge in hours per day and days per month; average summer and winter temperature of discharge(s) in degrees centigrade; average pH in standard units; and average daily discharges in pounds per day of BOD5, Total Suspended Solids, Total Iron, Total Manganese, and Total Aluminum (if bauxite or bauxitic clay or if otherwise believed present):

Outfall E/P	Information Source - # of Samples	Flow (cfs)	Flow (gpd)	Frequency (hours/day)	Frequency (days/month)	Sum/Win Temp, (°C)	pH (s.u.)	BOD5 (lbs/day)	TSS (lbs/day)	Tot Fe (lbs/day)	Tot Mn (lbs/day)	Tot Al (lbs/day)
001E	66	0.0031	0.002	24	Year Around	26/7	6.96	0.327	0.062	0.118	0.012	0.001
								Historical		Historical	Historical	Historical

Vulcan Materials Company

Directors

- Melissa H. Anderson (Director since 2019)
- Thomas A. Fanning (Director since 2015)
- O. B. Grayson Hall, Jr. (Director since 2014)
- J. Thomas Hill (Chairman of the Board, President and Chief Executive Officer
Director since 2014)
- Cynthia L. Hostetler (Director since 2014)
- Richard T. O'Brien (Director since 2008)
- James T. Prokopanko (Director since 2009)
- Kathleen L. Quirk (Director since 2017)
- David P. Steiner (Director since 2017)
- Lee J. Styslinger, III (Director since 2013)
- George Willis (Director since 2020)

Officers

- J. Thomas Hill (Chairman of the Board, President and Chief Executive Officer)
- Suzanne H. Wood (Senior Vice President and Chief Financial Officer)
- Thompson S. Baker II (Chief Operating Officer)
- Stanley G. Bass (Chief Strategy Officer)
- Denson N. Franklin III (Senior Vice President, General Counsel and Secretary)
- David P. Clement (Senior Vice President, Central, Mountain West and Western Divisions)
- Jerry F. Perkins Jr. (Senior Vice President, Southern & Gulf Coast and Southwest Divisions)
- Jason P. Teter (Senior Vice President, Mideast and Southeast Divisions)
- C. Wes Burton, Jr. (Vice President and Treasurer)
- Mary Andrews Carlisle (Vice President, Finance)
- M. Todd Freeman (Vice President, Internal Audit)
- Kevin T. Halcomb (Vice President, Tax)
- Janet F. Kavinoky (Vice President, External Affairs and Corporate Communications)
- Larry W. Miller (Vice President, Human Resources)
- Randy L. Pigg (Vice President and Controller)
- Lindsay L. Sinor (President, Vulcan Lands, Inc.)
- Mark D. Warren (Vice President, Investor Relations)

Vulcan Materials Company

Directors

- Melissa H. Anderson (Director since 2019)
- Thomas A. Fanning (Director since 2015)
- O. B. Grayson Hall, Jr. (Director since 2014)
- J. Thomas Hill (Chairman of the Board, President and Chief Executive Officer
Director since 2014)
- Cynthia L. Hostetler (Director since 2014)
- Richard T. O'Brien (Director since 2008)
- James T. Prokopanko (Director since 2009)
- Kathleen L. Quirk (Director since 2017)
- David P. Steiner (Director since 2017)
- Lee J. Styslinger, III (Director since 2013)
- George Willis (Director since 2020)

Officers

- J. Thomas Hill (Chairman of the Board, President and Chief Executive Officer)
- Suzanne H. Wood (Senior Vice President and Chief Financial Officer)
- Thompson S. Baker II (Chief Operating Officer)
- Stanley G. Bass (Chief Strategy Officer)
- Denson N. Franklin III (Senior Vice President, General Counsel and Secretary)
- David P. Clement (Senior Vice President, Central, Mountain West and Western Divisions)
- Jerry F. Perkins Jr. (Senior Vice President, Southern & Gulf Coast and Southwest Divisions)
- Jason P. Teter (Senior Vice President, Mideast and Southeast Divisions)
- C. Wes Burton, Jr. (Vice President and Treasurer)
- Mary Andrews Carlisle (Vice President, Finance)
- M. Todd Freeman (Vice President, Internal Audit)
- Kevin T. Halcomb (Vice President, Tax)
- Janet F. Kavinoky (Vice President, External Affairs and Corporate Communications)
- Larry W. Miller (Vice President, Human Resources)
- Randy L. Pigg (Vice President and Controller)
- Lindsay L. Sinor (President, Vulcan Lands, Inc.)
- Mark D. Warren (Vice President, Investor Relations)

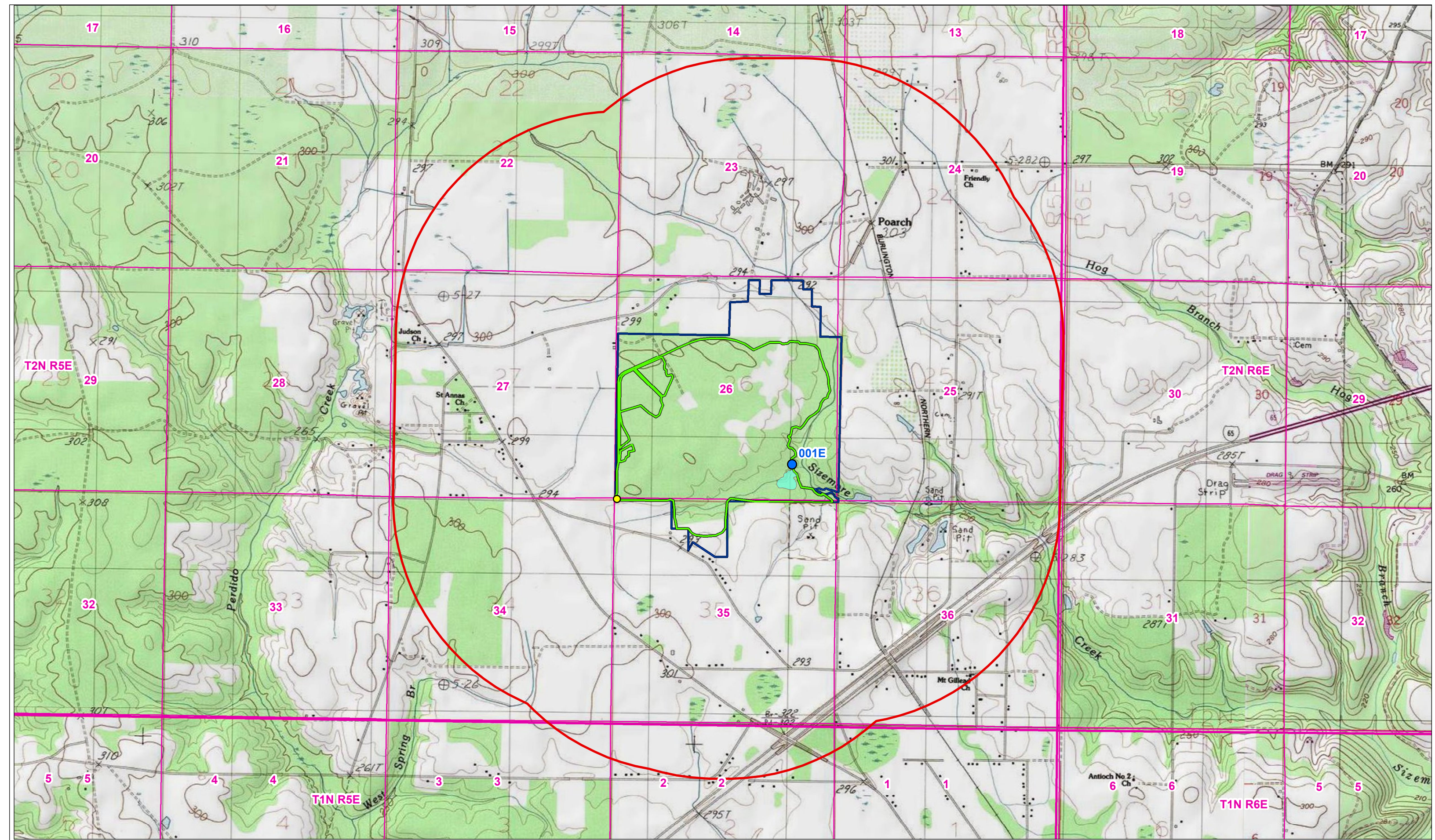

0 1,000 2,000
Feet



Photo Date: NA
Print Date: 08/29/2022

-  VMC Property
-  1-Mile Buffer
-  Permit Sign
-  Outfalls
-  Ponds
-  Disturbed Area

Vulcan Construction Materials, LLC
Atmore Quarry
Escambia County, AL



0 500 1,000 Feet



Photo Date: 2020, Google Earth Imagery
Print Date: 08/29/2022

- VMC Property
- Disturbed Area
- Permit Signs
- Outfalls
- Plant
- Pumps
- Office and Scales
- Containments
- Pumps
- Pump Directions
- Ponds
- Flow Direction

Vulcan Construction Materials, LLC
Atmore Quarry
Escambia County, AL

**POLLUTION ABATEMENT
AND/OR
PREVENTION PLAN**

**VULCAN CONSTRUCTION MATERIALS, LLC
ATMORE SAND AND GRAVEL
ATMORE, ALABAMA
ESCAMBIA COUNTY**

Permit No. - AL 0059498

August 2022



8/29/2022

Thomas S. Young

Engineer's Stamp

I. INTRODUCTION:

This Pollution Abatement/Prevention (PAP) plan is a required part of an application for a NPDES Permit. The Atmore Sand and Gravel Plant of Vulcan Construction Materials, LP is located in Escambia County at Township 2N, Range 5E, Sections 26 & 35, in the Freemanville Quadrangle as shown on the attached USGS map (Attachment 1). This application is being prepared in accordance with the rules and regulations of the Alabama Department of Environmental Management (ADEM). A thorough field review of the site has been conducted prior to the compilation and submittal of this plan to calculate runoff coefficients.

The PAP plan is presented in two parts, which includes a narrative description of the operation and treatment requirements, drainage maps and discharge calculations. The narrative description is intended to address the format as outlined by the ADEM Administrative Code R. 335-6-9. as well as present the basis for the designs as further detailed in the PAP. Drawings as presented in the PAP were derived from the rules and regulations of the ADEM Administrative Code R. 335-6-9, Appendix A and Appendix B, as well as from other generally accepted design data sources.

II. OPERATOR:

The owner/operator of this facility is Vulcan Construction Materials, LP. The plant is located at 1090 Old Jack Springs Road, Atmore, AL 36502.

Plant Mailing Address/Telephone#
P.O. Box 560
Atmore, AL 35616
(251) 368-1312

All Correspondence Should Be Addressed To
Vulcan Construction Materials, LP
Attn: Clarence Specht
P.O. Box 385016
Birmingham, AL 35238-5016
(205) 298-4000

III. GENERAL INFORMATION:

When operating this facility will employ 8 people on a full-time, basis and will produce mined sand and gravel. Typical operating hours are 4am to 4pm, 5 days a week. The site is comprised of some 513 drainage acres, approximately 300 of which is disturbed and made up of the sand and gravel processing areas, equipment storage and fueling areas, spoil and stockpile storage areas, haul roads, and quarry pit.

IV. TOPOGRAPHIC MAP:

Attachment 1 contains a 7.5 minute series USGS topographic map of the site extending to at least one mile beyond the property boundaries. **Attachment 2** contains a detailed site map, 1:500 or better, indicating site drainage, location of onsite facilities, spoil and material stockpile areas, diversionary structures, quarry pit (lakes), and discharge point.

V. METHOD OF DIVERTING SURFACE WATER RUNOFF:

The above-referenced maps show topography and all diversionary structures. The treatment structures are located using natural topography to minimize the construction of diversionary structures. Surface runoff from all spoils, stockpile areas, sand and gravel processing facilities, loading areas, equipment storage and fueling areas, and any other disturbed areas related to the mining site will be directed to a permitted treatment structures prior to discharging.

Storm water from disturbed areas will flow directly into the interconnected quarry pit lakes which total 130 acres in size and have a minimum of 15 feet of freeboard for storm water. These lakes are of more than sufficient size to hold and discharge the 25 year storm event.

The quarry pit lakes are comprised of a 52.7 acre lake and a 76.9 acre lake, where a mobile dredge is situated. These lakes overflow to a 4.2 acre settling pond. A pump, currently located in the largest lake, withdraws water from the lake for the gravel wash plant and then returns water to the lake in a recirculation system. The dredge moves around the pit and also withdraws and returns water in a recirculation system. The final settling pond discharges through permitted outfall 001 into Sizemore Creek.

Any minor areas of disturbance (mainly perimeter haul roads and berms) for which drainage can not feasibly be routed to the excavated pit and lake areas will have effective Best Management Practices (BMPs) fully implemented and maintained to control non-point source pollution.

VI. RAW MATERIALS, PROCESSES AND PRODUCTS:

Sand and gravel will be mined and gravel will be washed at this facility.

VII. SCHEMATIC DIAGRAM

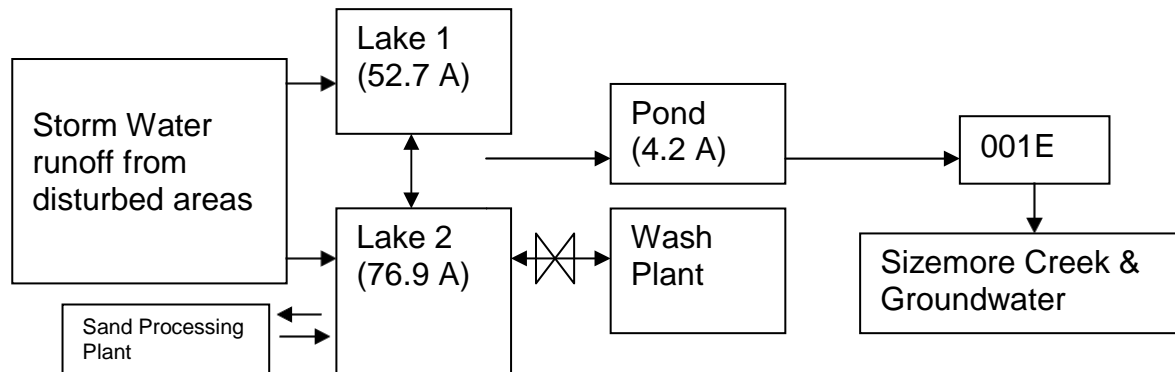

VIII. POST TREATMENT QUANTITY AND QUALITY OF EFFLUENT:

Runoff calculations have been provided as part of this plan. The treatment structures have been designed to allow adequate settling times for the expected particle sizes to reduce suspended solids concentrations to meet effluent limits. Data presented below is based on historical data for this site since the last permit application.

Average Values Based on 3-year Historical Data

Point Sources	pH (s.u.)	TSS (mg/L)	Flow (mgd)
001	6.96	3.71	0.002

IX. WASTE TREATMENT FACILITIES:

The primary method of treatment for the removal of suspended solids is settling. The treatment structures associated with point source 001E consist of two quarry pit lakes (52.7 and 76.9 acres, respectively) and a 4.2 acre setting pond that, at a minimum, provides 0.25 acre-feet of storage for every acre of disturbed land draining to the facilities. All trees, brush, boulders and other objects that would impair compaction were removed from the structures. The pits are excavated below the

surrounding ground surface and the excavated material was used to build up the sides of the ponds. Since the lakes were excavated below grade, there is no dam. The lakes have a minimum of 15 feet of freeboard.

The quarry pit lakes overflow to the settling pond which discharges through outfall 001E. The two spill pipes at point source 001E are sized to carry the peak flow from a 1-year storm event and are equip with an emergency spillway for a 25-year storm event. The spill pipes and are constructed of material that will not chemically react with the effluent. The spill pipes are equipped with subsurface withdrawal. A splash pad constructed of riprap is installed at the discharge outlet to prevent erosion from the discharge when it occurs.

Accumulated sediments in the settling ponds will be removed when the ponds have lost 60% of their liquid storage capacity due to sedimentation or as conditions warrant. Solids removed from the settling ponds are placed in a controlled area with other overburden material.

X. SEDIMENT CONTROL FOR HAUL ROADS:

The access and haul roads will have a sustained grade of no greater than 10%. The outer slope will be no steeper than 2:1. Effective BMPs will be installed and maintained at all times. The roads will be crowned and properly ditched. The haul roads will be located such that drainage goes to permitted treatment structures. There will be no stream crossings.

XI. LOCATION OF ALL STREAMS ADJACENT TO THE MINING AREA:

The topographic map submitted as part of this plan shows all water bodies. The only streams in the vicinity of this mining operation are Sizemore Creek and a tributary of Sizemore Creek. Haul roads do not have any stream crossings.

XII. NON-POINT SOURCE POLLUTION:

All disturbed areas are graded such that drainage will carry sediment to vegetated buffer areas, onsite BMPs, and the quarry pit. Non-point sources of pollution should not result from this facility.

XIII. PUBLIC WATER SUPPLY IMPOUNDMENT:

This facility will not discharge to a stream segment classified as a Public Water Supply.

XIV. SPILL PREVENTION, CONTROL AND COUNTERMEASURES PLAN

All petroleum tanks at this facility are currently closed therefor there is no Current SPILL plan. In the event that petroleum is stored at the facility an updated PAP including a spill plan will be submitted.

XV. RUNOFF CALCULATIONS

Design Flow Rate (Rational Method $Q=CIA$)

$Q=cfs$

$C=$ Runoff Coefficient

$I=$ Rainfall Intensity in/hr (25-yr)

$A=$ Area (acres)

001E: $Q = (0.50)(0.417)(383) = 79.9 cfs$

XVI. RECLAMATION PROCEDURE

During ongoing operation and reclamation, erosion and sediment control measures will be utilized as needed. The reclamation procedures will meet requirements of the Alabama Surface Mining Act of 1969, as amended by Act 99-579, and as regulated under permit reviewed and renewed annually by the Alabama Department of Industrial Relations (ADIR). Reclamation procedures will commence contemporaneously with ongoing mining activities, once all mining activities are completed in a portion of the total area to be mined.

A minimum 50-foot setback (undisturbed buffer) will be maintained between surface mining areas and areas which could be adversely affected by mining (watercourses, adjoining properties, or other features, as applicable).

XVII. BMP TYPICALS

Attachment 3 contains erosion and sediment control designs for typical BMPs that may be employed, as applicable, during operation of the mining activity.

XIX. GENERAL PIT OPERATION:

The operations at this facility include mining and processing of sand and gravel, washing, stockpiling, loading and shipping by customer truck.

**VULCAN CONSTRUCTION MATERIALS, LP
SOUTHERN AND GULF COAST DIVISION
ATMORE SAND & GRAVEL**

Point Source 001E - Calculations

Total Drainage Acres (513 acres) removing quarry pit lake area (130 acres) = 383 acres (A) of which approximately 300 is disturbed.

Total Drainage Acres = 383 acres (A)

Runoff Coefficient = 0.50 (C)

Rainfall for a 25-year storm event: 10 in./24-hours = 0.417 in./hr. (I)

Time of concentration is assumed to be 1-hour.

Design Flow Rate (cfs):

$$Q=CIA$$

$$Q=(0.50)(0.417)(383)$$

$$Q=79.9 \text{ cfs}$$

Quarry Pit Lakes and Treatment Pond (required size):

Volume based on design flow:

- Design for 1-hour storage of design runoff
- Volume=(79.9 cfs)(60 min/hr)(60 sec/min)
Volume required=287,640 ft³

Volume based on 0.25 acre feet/acre requirement:

- 0.25 acre feet/acre X 383 acres = 95.75 acre feet
Volume required = 4,170,870 ft³ (Governs)
- Pond volume of 4,170,870 ft³ required.

Structure	Area (ft ²)	Avg. Depth (ft)	Available Volume
Lake (52.7 A)	2,295,612 ft ²	10 ft	22,956,120 ft ³
Lake (76.9 A)	3,349,764 ft ²	10 ft	33,497,640 ft ³
Pond (4.2 A)	182,952 ft ²	10 ft	1,829,520 ft ³

- Total Volume Available= **58,283,280 ft³** > **4,170,870 ft³** (required volume).

Outlet Pipe (1 Year Storm)

- Flow Rate = 33.89 cfs
- 1 Year Storm Event = 4.25 in/24hr
- Using open channel flow equations: $Q=(1.49)(AR^{2/3})(S^{1/2}/n)$
n=0.014
S=0.02
- Solving equation yields two 26" diameter steel pipes will handle the required flow.
- The settling pond associated with outfall 001 is equip with an emergency spillway.

**X-SECTION OF TWO OUTLET PIPES – 001E
(Not to Scale)**

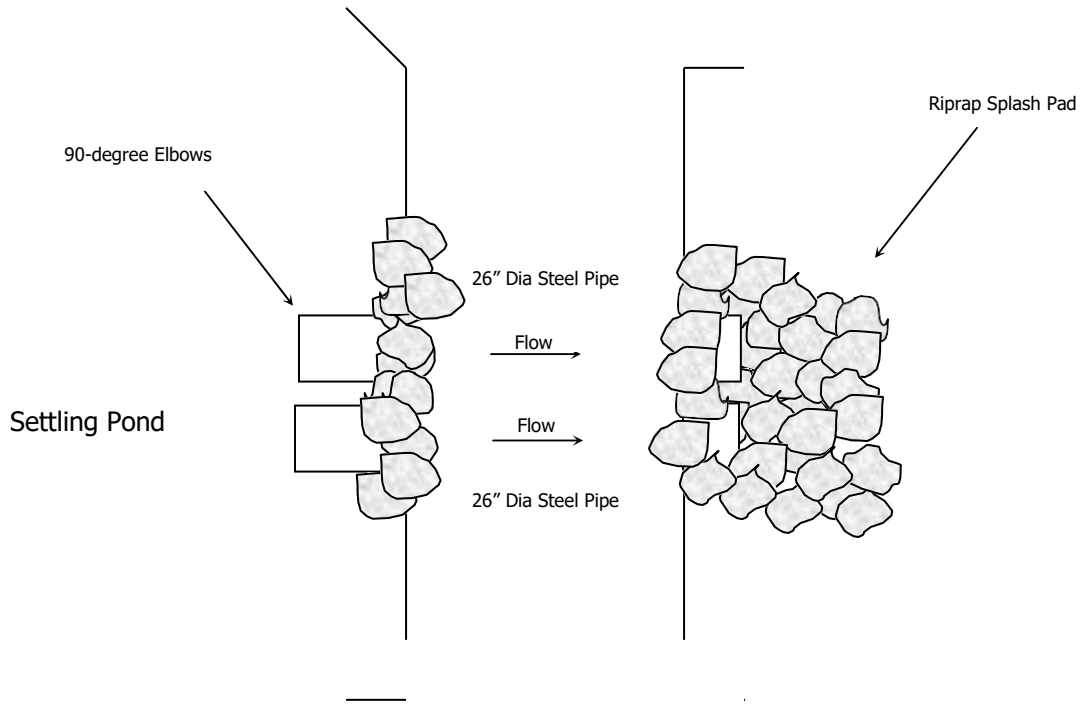
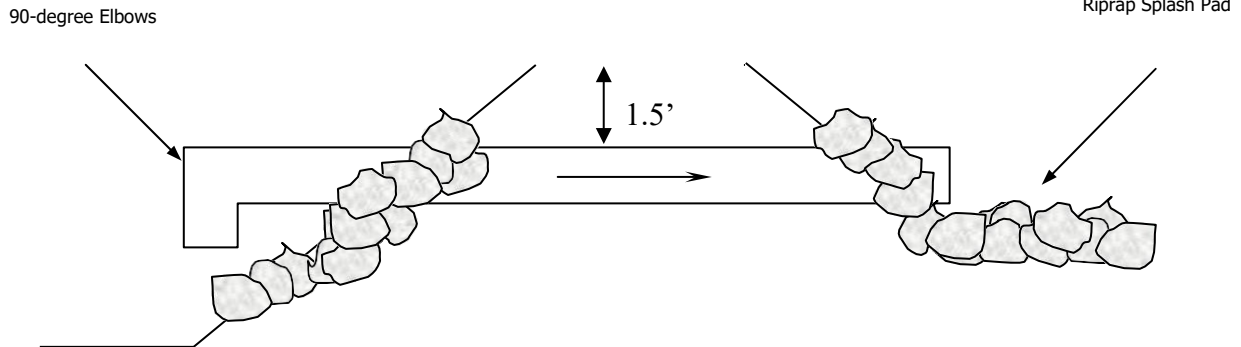

ATTACHMENT 1

7.5 Minute Series USGS Topographic Map

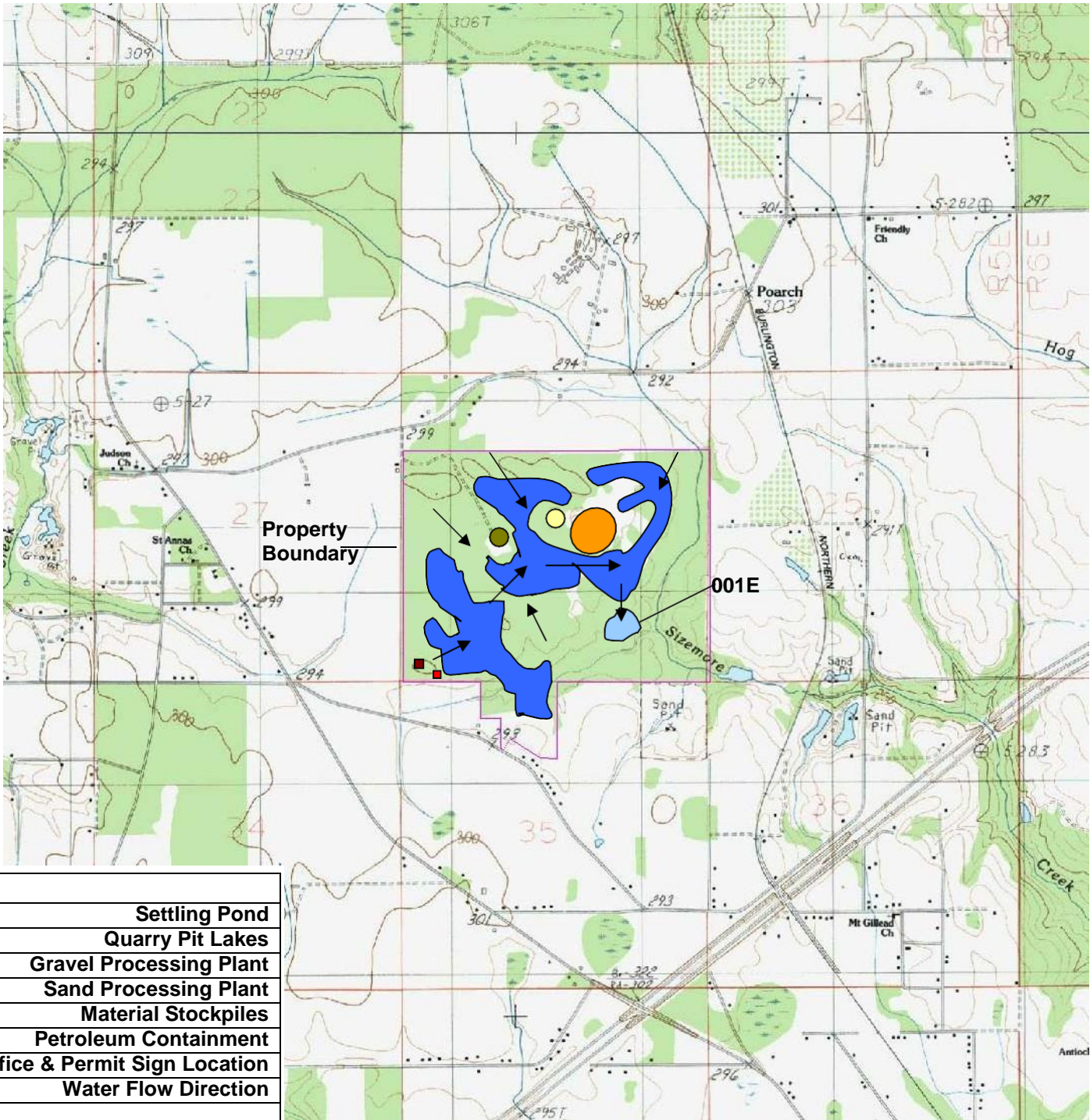







Legend	
	Settling Pond
	Quarry Pit Lakes
	Gravel Processing Plant
	Sand Processing Plant
	Material Stockpiles
	Petroleum Containment
	Office & Permit Sign Location
	Water Flow Direction

Exhibit A
Vulcan Construction Materials, LP
Atmore Sand & Gravel
Escambia County, Alabama

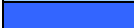
Freemanville Quadrangle	
Township	2N
Range	5E
Section	26 & 35
Scale	1"=2,500'
May 18, 2011	

ATTACHMENT 2

Site Map



Legend	
	Outfall 001E Location
	Wash Plant Pump (recirc.)
	Petroleum Containment
	Office & Permit Sign Location
	Surface Runoff Direction
	Property Lines

Exhibit B
Vulcan Construction Materials, LP
Atmore Sand & Gravel
 Escambia County, Alabama

Freemanville Quadrangle	
Aerial Photo Date: Oct 2010	
Township	2N
Range	5E
Section	26 & 35
Scale	1"=500'
May 18, 2011	

ATTACHMENT 3

Design Typicals

VULCAN CONSTRUCTION MATERIALS, LP
ATMORE SAND AND GRAVEL

DESIGN TYPICALS FOR STORM WATER RUNOFF BMPs

Diversion Berms

Earthen and rock structures (berms) are typically used for storm water retention or diversion to sediment treatment facilities and BMPs. These berms are constructed of indigenous soils that are compacted. The compacted berm is then covered with riprap for stability. Below is a diagram of a typical berm:

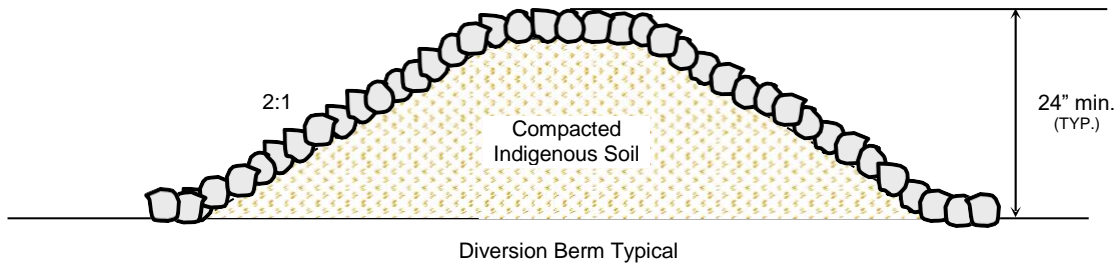

Large Berms (Overburden Berms)

Large earthen berms consisting of overburden material are used for storm water diversion as well as for a buffer to the active quarry. The berms are constructed of indigenous soils that have been stripped from the active stone removal portions of the quarry. The berms are hydro-seeded with indigenous grass to stabilize the compacted material. Below is a diagram of the typical large buffer berm:

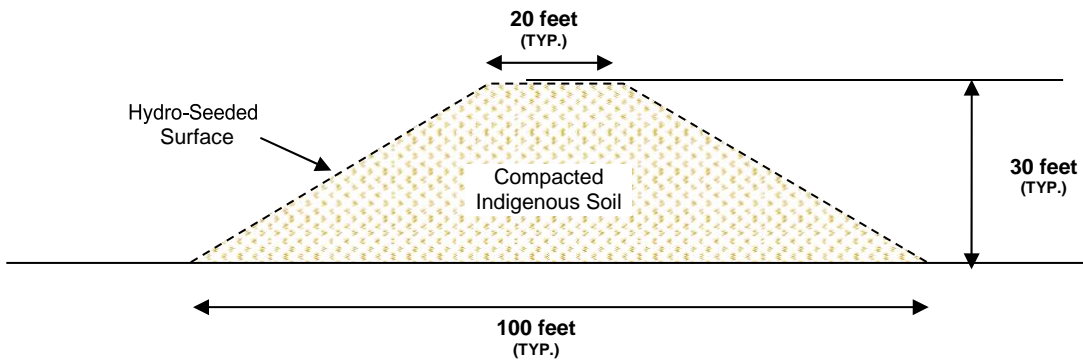

VULCAN CONSTRUCTION MATERIALS, LP
ATMORE SAND AND GRAVEL

DESIGN TYPICALS FOR STORM WATER RUNOFF BMPs

Rock Check Dams

A check dam is a small barrier or dam constructed across a swale, drainage ditch or other area of concentrated flow for the purpose of reducing channel erosion by reducing the velocity of the channel flow. Rock check dams are commonly used at quarry sites to slow the velocity of channeled storm water runoff and act in concert with other BMPs. Check dams at this site are constructed of stone that varies in size from Gabion size to riprap. Below is a diagram of a typical rock check dam at this facility:

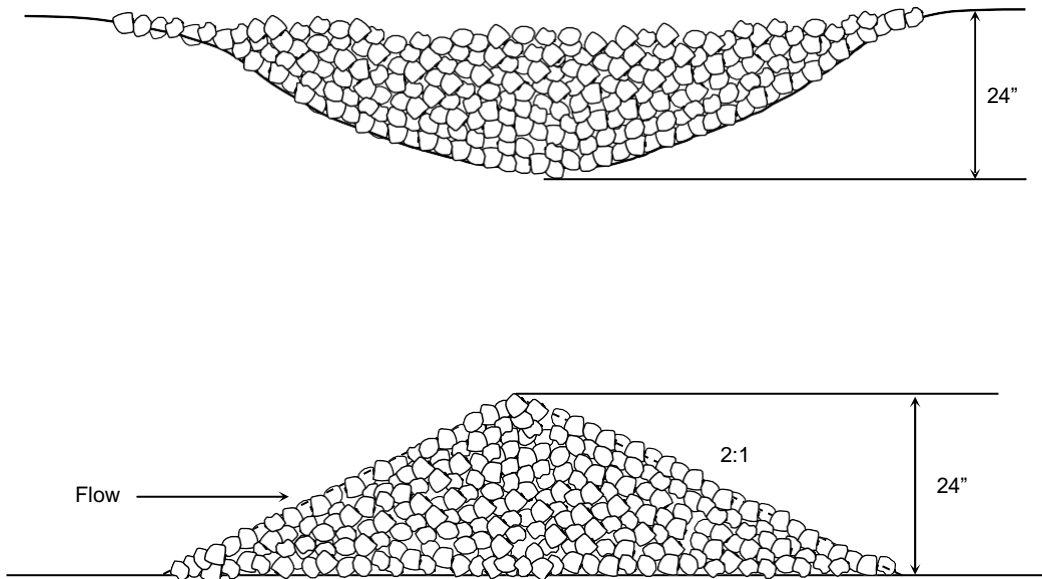

Cut-Off Trench (Ditch)

A cut-off trench is a structure used to direct storm water runoff to other storm water BMPs such as a settling pond. Cutoff trenches are used to direct storm water runoff from portions of the stockpile area to the settling ponds. Below is a diagram of a typical cut-off trench (ditch):

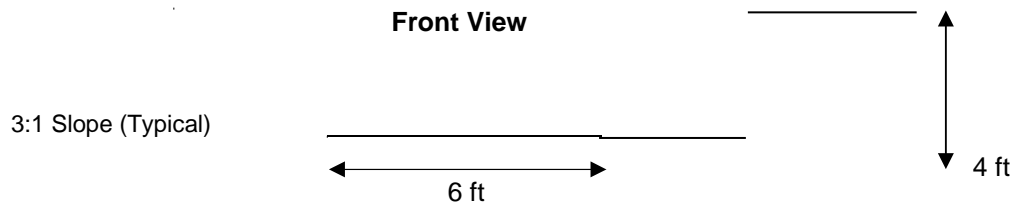

VULCAN CONSTRUCTION MATERIALS, LP
ATMORE SAND AND GRAVEL

DESIGN TYPICALS FOR STORM WATER RUNOFF BMPs

Sediment Barrier

A sediment barrier is a temporary structure used across a landscape to reduce the quantity of sediment that is moving farther down slope. Commonly used barriers include silt fence (a geotextile fabric which is trenched into the ground and attached to supporting posts) or hay bales trenched into the ground. Other barrier materials include sand bags, brush piles and various man-made materials that can be used in a similar manner as silt fence and hay bales. Silt fence is commonly used at stone quarries to control runoff from active spoil areas and berms that have not yet vegetated where the runoff cannot be diverted to a quarry pit or pond system. Below is a diagram of a typical Type A silt fence installation at this facility:

